

DMV2000 Technical Manual v3.0

Revision History

Version	Revision	Date
V1.0	The first version was published.	2016/07/15
V2.0	<ol style="list-style-type: none">1. Update information concerning the Codes for camera shutter speed setting in Chapter 8.2. New contents concerning Modbus Master Mode Communication Method for RS232, RS485 and Ethernet in Chapter 8.	2016/12/30
V3.0	<ol style="list-style-type: none">1. Contents format adjustment in Chapter 3.2. Section 3.3.3 is updated.3. Update information concerning all Inspections in Chapter 5.4. Contents of Status Item are revised in Chapter 6.5. Update information concerning Modbus Master Mode Communication Method for RS232, RS485 and Ethernet in Chapter 8.	2017/12/25

Thank you for selecting the high-performance Digital Machine Vision System DMV2000 series from Delta Electronics Inc. This Operating Manual contains descriptions of all the components and provides information on installation, process configuration, operation, troubleshooting, peripherals, and maintenance.

To guarantee proper installation and operation of the system, please carefully read this Operating Manual and keep it in a safe place for future reference.

Caution

1. To prevent damage due to an incorrect input voltage level, please ensure that all signal connections, such as input voltage and polarity, are correct before powering on any component.
2. Please ensure that system power is turned off before inspecting the input power source or connecting the wires. To avoid electrical shock, never touch the terminals or connect the wires while system power is turned on.
3. Please do not attempt to disassemble or modify the internal components of the controller.
4. The controller unit is an open-type chassis and must be installed within an appropriate panel box that repels dust, water, and moisture; and prevents electrical shock and damage from impacts.
5. Keep the components away from scrap metal, which could interfere with operation or cause damage to the components.
6. During installation, keep the components away from sources of electrical interference such as high voltage and high frequency noise. Avoid system operation under the following situations:
(a) Excessive dust and corrosive gasses; (b) high temperature, high humidity, and high levels of radiation; (c) shock and impact; (d) exposure to direct sunlight
7. Please clean the system with a dry cloth. Do not use cleaning solutions containing acidic or alkaline chemicals.
8. Ensure a proper connection is established between the ground terminal and the power source. Ensure that all terminals are securely connected.
9. Use only compressed air to remove dust from the camera sensor and lens. To avoid getting moisture on the components, never blow on any of the components with your mouth.
10. Gently wipe dust off of the lens using a lens cloth to remove attached dirt. Using excessive force or inappropriate materials may scratch the lens.
11. Allow at least 10 seconds to pass before you restart the system after powering the system off to avoid damage to the components.

DMV2000 Technical Manual V3.0

Table of Contents

Chapter 1: Components and Specifications

1.1 Packaging and Optional Parts	1-1
1.1.1 Controller Unit Packaging	1-1
1.1.2 Camera (Optional: 2nd–4th Camera Expansion)	1-2
1.1.3 Lens (Optional)	1-3
1.1.4 LED Light Source (Optional)	1-4
1.2 Controller Unit	1-5
1.2.1 Specifications	1-5
1.2.2 Names of Controller Components	1-8
1.2.3 Camera Installation and Dimensions	1-9
1.3 Camera and Lens Selections	1-13
1.4 Grounding and Installation	1-22
1.4.1 Grounding	1-22
1.4.2 Installation	1-22

Chapter 2: Input and Output Interface

2.1 Input/Output (I/O) Terminal Block	2-2
2.1.1 9-Pin Input Terminal	2-3
2.1.2 12-Pin Output Terminal	2-4
2.1.3 Input/Output Contacts Descriptions.....	2-6
2.2 RS232/RS485 Serial Output	2-7
2.2.1 RS232/RS485 Pins	2-8
2.3 Ethernet Output	2-9
2.4 MicroSD Card	2-9

Chapter 3: Basic Operation

3.1 Main Page	3-1
3.2 Project Setup	3-3
3.3 Tool Setting	3-5
3.3.1 Register Image Management	3-5
3.3.2 Screen Editing	3-8
3.3.3 Judge Setting	3-12
3.4 System Setting	3-16
3.4.1 General Setting	3-16
3.4.2 Camera Setting	3-17

3.4.3 Communication Setting	3-25
3.4.4 Display Setting	3-37
3.4.5 Environment Setting	3-39
3.4.6 System Info.	3-39
3.4.7 Software Update	3-41

Chapter 4: Inspection System and Process Settings

4.1 Process Editing and Setting	4-1
4.1.1 Add Project	4-2
4.1.2 Inspection Process Setting	4-2
4.2 Flow Process Camera Setting	4-13
4.3 Draw ROI	4-22
4.3.1 Draw a Rectangle	4-23
4.3.2 Draw a Circle	4-24
4.3.3 Draw a Polygon	4-25
4.3.4 Draw an Ellipse	4-28
4.3.5 Draw a Ring	4-30
4.3.6 Draw an Arc	4-31
4.3.7 Draw a Rotated Rectangle	4-33
4.4 Add Inspections and Overview of Functions	4-35
4.4.1 Inspections	4-36
4.4.2 Calculate, Input, and Output	4-39
4.5 Result Output and Status Item	4-45
4.5.1 Result Output	4-45
4.5.2 Status Item	4-48
4.6 Run Mode	4-51

Chapter 5: Inspection

5.1 Area	5-1
5.2 Blob	5-6
5.3 Stain	5-18
5.4 Edge Angle	5-28
5.5 Edge Count	5-36
5.6 Edge Pitch	5-43
5.7 Edge Position	5-54
5.8 Edge Width	5-64
5.9 Shape	5-75
5.10 Intensity	5-81
5.11 Position Trace	5-86
5.12 Width Trace	5-98

5.13 OCV	5-108
5.14 Bar Code	5-122
5.15 2D Bar Code	5-128
5.16 1P Position	5-133
5.16.1 Coordinate Conversion Matrix Models	5-133
5.16.2 The Coordinate Conversion Matrix	5-135
5.17 1P Location	5-149
5.17.1 Coordinate Conversion Matrix Models	5-149
5.17.2 The Coordinate Conversion Matrix	5-151

Chapter 6: Calculate, Result Output, Status Item

6.1 What is a Calculator	6-1
6.2 Edit Calculator Functions	6-3
6.2.1 Calculator Interface	6-3
6.2.2 Variable and Parameter Functions	6-5
6.3 What is an Output	6-25
6.3.1 Result Output Configurations	6-25
6.4 What is a Status Item	6-30
6.4.1 Status Item Configurations	6-30

Chapter 7: Input and Output I/O Terminal

7.1 Definition of the I/O Functions	7-3
7.2 I/O Activation Timing	7-6
7.2.1 TRIG (Trigger) Capture	7-6
7.2.2 Flash Timing	7-9
7.2.3 External Terminal Result Output	7-13
7.2.4 Communication Result Output	7-18
7.2.5 Function Switch: FNC1~4, IN1~8, FRDY, FCH, SW, NSW	7-19
7.2.6 Others: TROFF, TEST, RESET	7-23

Chapter 8: Serial Communication

8.1 RS232/RS485 Serial Communication Mode	8-1
8.2 RS232/RS485 Private Code Communication Mode	8-2
8.2.1 Private Code Mode Command Table: (DMV2000 Custom Communication Format)	8-3
8.2.2 Private Code Mode Command: (DMV2000 Communication Format)	8-4
8.2.3 Private Code Custom Output Data Format	8-16
8.3 PLC Automatic Linking Communication Mode	8-20
8.4 MODBUS Master Mode Communication Mode	8-23
8.4.1 Modbus ASCII Master Mode Command Table:	8-24
8.4.2 Modbus TCP Master Mode Command Table:	8-25

8.5 MODBUS Communication Method	8-25
8.5.1 Slave Mode Command Table: (Modbus Communication Format)	8-26
8.6 ASCII Code Table	8-41
8.7 Ethernet Private Code Communication	8-42
8.7.1 Ethernet Private Code Mode Command Table: (DMV2000 Custom Communication Format)	8-43
8.7.2 Ethernet Private Code Mode Commands: (DMV2000 Custom Communication Format)	8-44
8.7.3 Ethernet Private Code Custom Output Data Format	8-45
8.8 Ethernet Modbus Server Mode Communication Method	8-49
8.8.1 Ethernt Modbus ASCII Server Mode Command Table:	8-50
8.8.2 Ethernt Modbus TCP Server Mode Command Table:	8-51
8.9 Ethernet MODBUS TCP Communication Method	8-52
8.9.1 Ethernet Client Mode Command Table: (Modbus TCP Communication Format)	8-52

Chapter 9: Appendix

9.1 Locate	9-1
9.1.1 Locate Parameters	9-2
9.1.2 Reference Tools that Use Locate	9-2
9.1.3 Locate Configuration Process	9-5
9.2 Preprocess	9-9
9.2.1 Preprocess Types	9-9
9.2.2 Custom Filter	9-14
9.3 Lighting	9-21
9.3.1 Lighting Method	9-21
9.4 Color	9-24
9.4.1 Color Condition Configuration	9-24

Chapter 1

Components and Specifications

1.1 Packaging and Optional Parts

A complete DMV system includes the following basic components:

- 1) Controller unit and mouse
- 2) Camera and transmission cable (optional)
- 3) Lens (optional)
- 4) Light source and dimmer (optional)

1.1.1 Controller Unit Packaging

The following is included:

- 1) DMV2000-CL2-HS (DMV2000-CL4-HS) controller unit
- 2) Mouse
- 3) Camera
- 4) Camera transmission cable

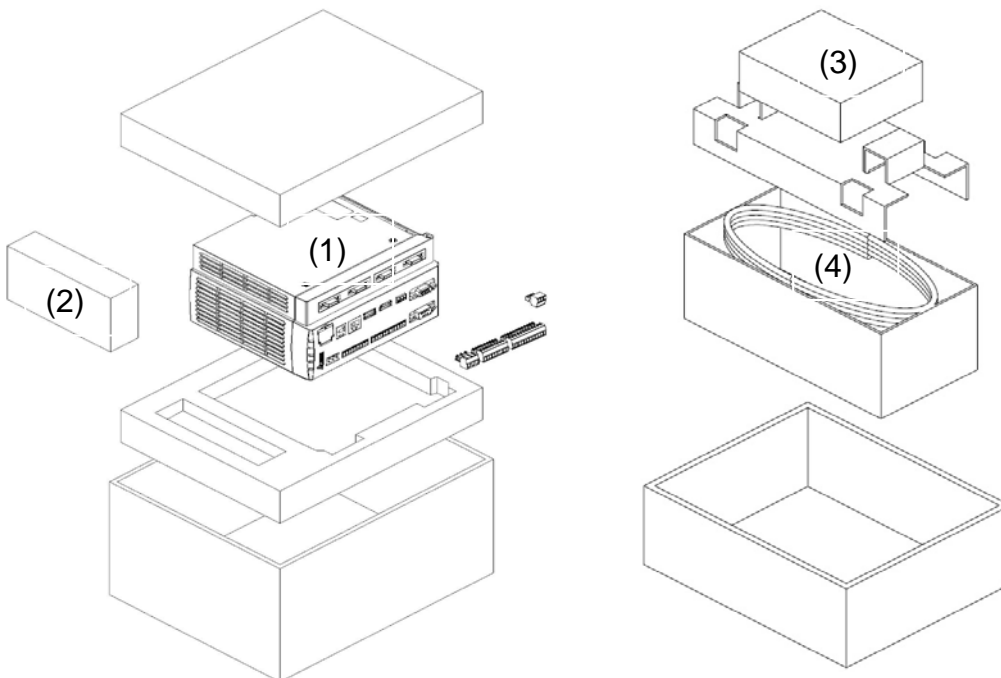

1.1.2 Camera (Optional: 2nd–4th Camera Expansion)

The camera uses the Camera Link transmission interface, and is equipped with standard CH1 and CH2 transmission ports. When using only one transmission cable, please connect the DMV2000 main unit to the CH1 port. When increased camera transmission speeds are required (increased frame rate), please connect the DMV2000 main unit to both the CH1 and CH2 ports (that is, connect to both Camera-1 and Camera-2 ports on the DMV2000).

◎ 0.3 MP Camera

Specifications: 1/3" COMS chip, C mount port, 480 fps, 7.4 μ m chip size

- 0.3 MP (640*480) color camera: DMV-CM30CCL
- 0.3 MP (640*480) gray-scale camera: DMV-CM30GCL

◎ 2 MP Camera

Specifications: 2/3" COMS chip, C mount port, 295 fps, 5.5 μ m chip size

- 2 MP (2048*1088) color camera: DMV-CM2MCCL
- 2 MP (2048*1088) gray-scale camera: DMV-CM2MGCL

◎ 4 MP Camera

Specifications: 1" COMS chip, C mount port, 159 fps, 5.5 μ m chip size

- 4 MP (2048*2048) color camera: DMV-CM4MCCL
- 4 MP (2048*2048) gray-scale camera: DMV-CM4MGCL

◎ 5 MP Camera

Specifications: 2/3" CCD chip, C mount port, 16 fps, 3.45 μ m chip size

- 5 MP (2448*2058) color camera: DMV-CD5MCCL
- 5 MP (2448*2058) gray-scale camera: DMV-CD5MGCL

◎ 12 MP Camera

Specifications: 1.76" COMS chip, F mount port, 50 fps, 5.5 μ m chip size

- 12 MP (4096*3072) color camera: DMV-CM12MCCL
- 12 MP (4096*3072) gray-scale camera: DMV-CM12MGCL

1.1.3 Lens (Optional)

- ◎ **2/3" Normal Lens (more distortion)** 2/3" image size, C-mount port
Applicable for 0.3 MP camera
 - 6 mm focal length lens: DMV-LN06W40
 - 8 mm focal length lens: DMV-LN08W40
 - 12 mm focal length lens: DMV-LN12W40
 - 16 mm focal length lens: DMV-LN16W40
 - 25 mm focal length lens: DMV-LN25W40
 - 35 mm focal length lens: DMV-LN35W40
 - 50 mm focal length lens: DMV-LN50W40
 - 75 mm focal length lens: DMV-LN75W40
 - 100 mm focal length lens: DMV-LN100W40

- ◎ **2/3" Megapixel Lens (less distortion):** 2/3" image size, C-mount port
Applicable for 2 MP camera
 - 5 mm focal length lens: DMV-LN05M
 - 8 mm focal length lens: DMV-LN08M
 - 12 mm focal length lens: DMV-LN12M
 - 16 mm focal length lens: DMV-LN16M
 - 25 mm focal length lens: DMV-LN25M
 - 35 mm focal length lens: DMV-LN35M
 - 50 mm focal length lens: DMV-LN50M

- ◎ **1" Megapixel Lens (less distortion):** 1" image size, C-mount port
Applicable for 4 and 5 MP cameras
 - 12 mm focal length lens: DMV-LN12M06 (high resolution series)
 - 16 mm focal length lens: DMV-LN16M06 (high resolution series)
 - 25 mm focal length lens: DMV-LN25M06 (high resolution series)
 - 35 mm focal length lens: DMV-LN35M06 (high resolution series)
 - 50 mm focal length lens: DMV-LN50M06 (high resolution series)
 - 12 mm focal length lens: DMV-LN12M05 (normal resolution series)
 - 35 mm focal length lens: DMV-LN35M05 (normal resolution series)
 - 50 mm focal length lens: DMV-LN50M05 (normal resolution series)

- ◎ **Parallel Light Lens (Telecentric Lens)**
 - 50 mm focal length: DMV-LN50T

1.1.4 LED Light Source (Optional)

◎ Ring Light Source

- ▶ Red light: DMV-DR6736R
- ▶ White light: DMV-DR6736W
- ▶ Diffuser Plate: DMV-DR6736D

30° lighting angle; 36 mm inner radius; 67 mm outer radius for general text surfaces

◎ Coaxial Light Source

- ▶ White Light: DMV-CX40W

40 mm * 40 mm glass window for highly reflective (e.g., metal) surfaces

◎ Backlight

- ▶ Red Light: DMV-BL60R

60 mm * 60 mm for backlight illumination during size measurement

◎ Power Supply

- ▶ One channel output: DMV-PS12C1
- ▶ Two channel output: DMV-PS12C2
- ▶ Power extension cord: DMV-CA30P

The flashlight controller is built into the power supply and the DMV-CA30 (3 m) is included when you purchased a light source.

1.2 Controller Unit

1.2.1 Specifications

◆ General Specifications

Input power	24 VDC
Operation voltage	90%–110% of rated voltage
Current consumption	Two cameras: <3.4 A Four cameras: <4 A
Vibration resistance	No error (normal operation): 3-axis; 10–55 Hz; 10 m/s (1.0 G); 10 min. No damage: 3-axis; 10–55 Hz; 20 m/s (2.0 G); 10 min.
Shock resistance	No error (normal operation): 200 m/s (20 G); 3 drops; 3 edges, 6 surfaces, and 1 corner No damage: 300 m/s (30 G); 3 drops; 3 edges, 6 surfaces, and 1 corner
Operating temperature	0–45°C
Storage temperature	-20°C to +65°C
Operating humidity	35–65% RH (non-condensing)
Operating altitude	Lower than 2,000 m
Battery lifespan	More than 5 years

◆ Functional Specifications

Camera	Type	Camera Link digital color/gray-scale camera
	Resolution	0.3 MP Camera: 642 (H) * 484 (V), Base: 480 fps
		2 MP Camera: 2048 (H) * 1088 (V), Base: 74 fps, Full: 295 fps
		4 MP Camera: 2048 (H) * 2048 (V), Base: 40 fps, Full: 159 fps
		5 MP Camera: 2448 (H) * 2058 (V), Base: 16 fps
		12 MP Camera: 4096 (H) * 3072 (V), Base: 13 fps, Full: 50 fps
	Connected systems	DMV2000-CL2-HS maximum 2 units DMV2000-CL4-HS maximum 4 units
	Shutter speed	0.3 MP: 20 μs–16.777 s 2 MP: 22 μs–45 s 4 MP: 22 μs–45 s 5 MP: 4.8 μs–0.125 s 12 MP: 42 μs–1 s
	Lens mount	C mount (F mount for 12 MP)
	Operating temperature	0°C–45°C
Storage temperature	-20°C to +65°C	

Chapter 1 Components and Specifications

Project quantity		Internal memory: 1000 Memory card: additional memory space; upper limit at 9999 May switch through I/O and communication ports (RS232/485, Ethernet)
Inspection window	Quantity	Maximum 1000 per project
	Inspection component	Area, blob, stain, edge angle, edge count, edge pitch, edge position, edge width, shape, intensity, position trace, width trace, OCV, Bar Code, 2D Bar Code 1P Position, 1P Location
	ROI type	Rectangle, circle, polygon, ellipse, circle, arc, rotation rectangle
	Number of ROIs	1
	Mask type	Rectangle, circle, polygon, ellipse, circle, arc, rotation rectangle
	Mask quantity	8 (each inspection window)
Preprocess	Quantity	13
	Type	Binary, dilation, erosion, average, median, Laplacian, Sobel X, Sobel Y, Sobel XY, custom, brightness, contrast, shade
Run mode		Always execute, never execute
Calculation processing	Quantity	Maximum 1000 sets (each project)
	Arithmetic	Add, subtract, multiply, divide
	Function (71 types)	EQ ; NOT_EQ ; LT ; LE ; GT ; GE ; AND ; BIT_AND ; OR ; BIT_OR ; XOR ; BIT_XOR ; NOT ; BIT_NOT ; INRANGE ; CHOOSE ; IF ; MAX_INDEX ; MIN_INDEX ; MAXth_INDEX ; MINth_INDEX ; ABS ; POW ; MOD ; LOG10 ; LN ; EXP ; SQR ; SQRT ; SUM ; TRUNC ; ROUND ; CEIL ; FLOOR ; SIN ; COS ; TAN ; ASIN ; ACOS ; ATAN ; ATAN2 ; RAD ; DEG ; PI ; MAX ; AVG ; AVG_RANGE ; MIN ; SDEV ; MEDIAN ; MODE ; LINE_FIT ; CIRCLE_FIT ; POINT_TO_POINT ; POINT_TO_LINE ; POINT_TO_CIRCLE ; POINT_TO_POINT_DIST ; POINT_TO_POINT_ANGLE ; LINE_ANGLE ; LINE_MIN_ANGLE ; LINE_TO_LINE ; LINE_TO_CIRCLE ; CIRCLE_TO_CIRCLE ; BLOB_TO_POINT ; BLOB_TO_LINE ; BLOB_TO_BLOB ; BLOB_TO_POINT_ANGLE ; STAIN_TO_POINT ; STAIN_TO_LINE ; STAIN_TO STAIN ; STAIN_TO_STAIN_ANGLE
Communication port		Programmable input pins: 8 (high speed); 24 (normal) Programmable output pins: 11 (high speed); 38 (normal) RS232 (maximum 115,200 bps), RS485 (maximum 230,400 bps), Ethernet (10/100/1000BASE-T), Delta PLC-Link
Display	Monitor Display	FHD 1920*1080 output, XGA 1024*768 output (currently unsupported)

	Display ratio	Adjustable 5–1000%
	Operating language	Traditional Chinese, English
	Output interface	VGA, HDMI
Operating interface	Mouse	Standard 3-button USB
Flash control		DMV2000-CL2-HS: Setup output control through I/O contact, supports a maximum of 2 sets DMV2000-CL4-HS: Setup output control through I/O contact, supports a maximum of 4 sets
Type of memory card		MicroSD card (supports maximum 32GB); Class 10

1.2.2 Names of Controller Components

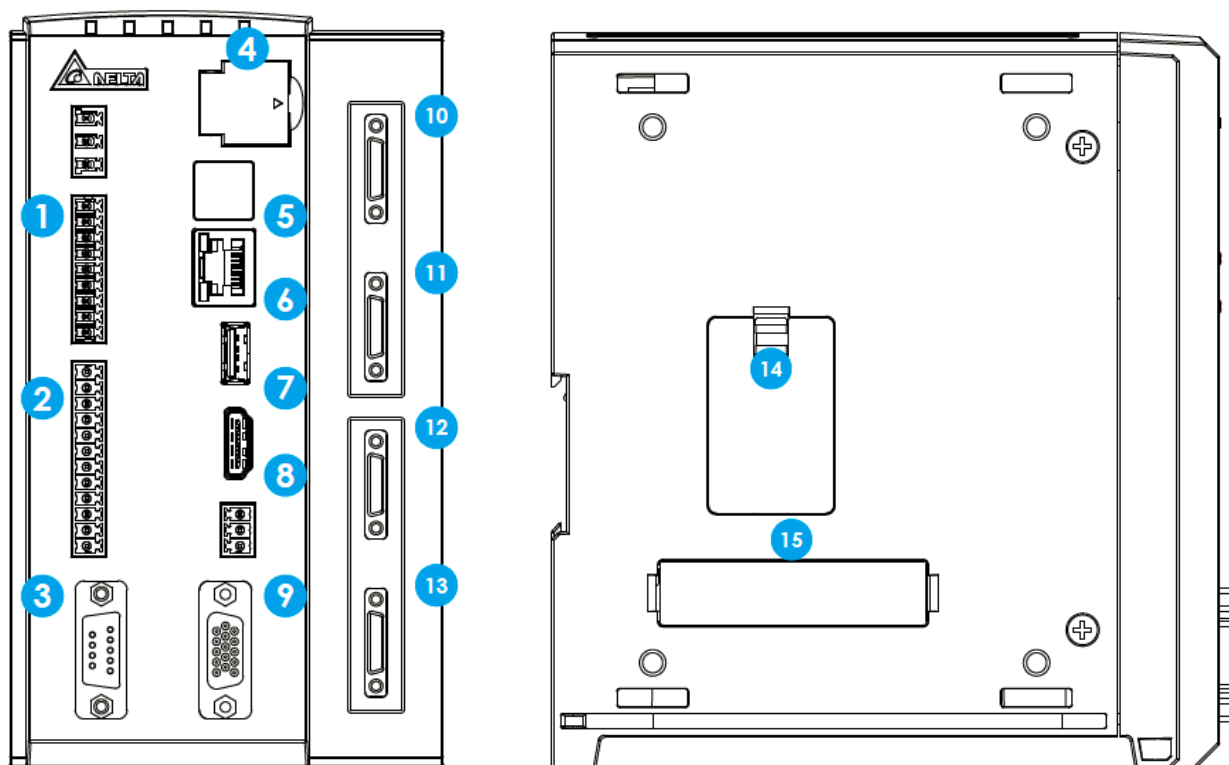

Serial No.	Name	Description
1	Input I/O terminal block	Input terminal (8 pin)
2	Output I/O terminal block	Output terminal (11 pin)
3	RS-232 serial port	Supports master/slave serial communication
4	SD card	Saves project configuration and image backup
5	Ethernet port	10/100/1000 BASE-T communication
6	USB 2.0 port	Mouse interface
7	HDMI output port	Connects to commercial HDMI interfaced displays
8	RS-485 serial port	Supports master/slave serial communication
9	VGA output port	Connects to commercial VGA interfaced displays
10	Camera 1 port	Ports for 0.3, 2, 4, 5, and 12 MP cameras
11	Camera 2 port	Ports for 0.3, 2, 4, 5, and 12 MP cameras
12	Camera 3 port	Ports for 0.3, 2, 4, 5, and 12 MP cameras
13	Camera 4 port	Ports for 0.3, 2, 4, 5, and 12 MP cameras
14	Button cell port	Powers system clock operation
15	Expansion port	Light source control, I/O extension

1.2.3 Camera Installation and Dimensions

© 0.3 MP Camera

Dimensions in millimeters.

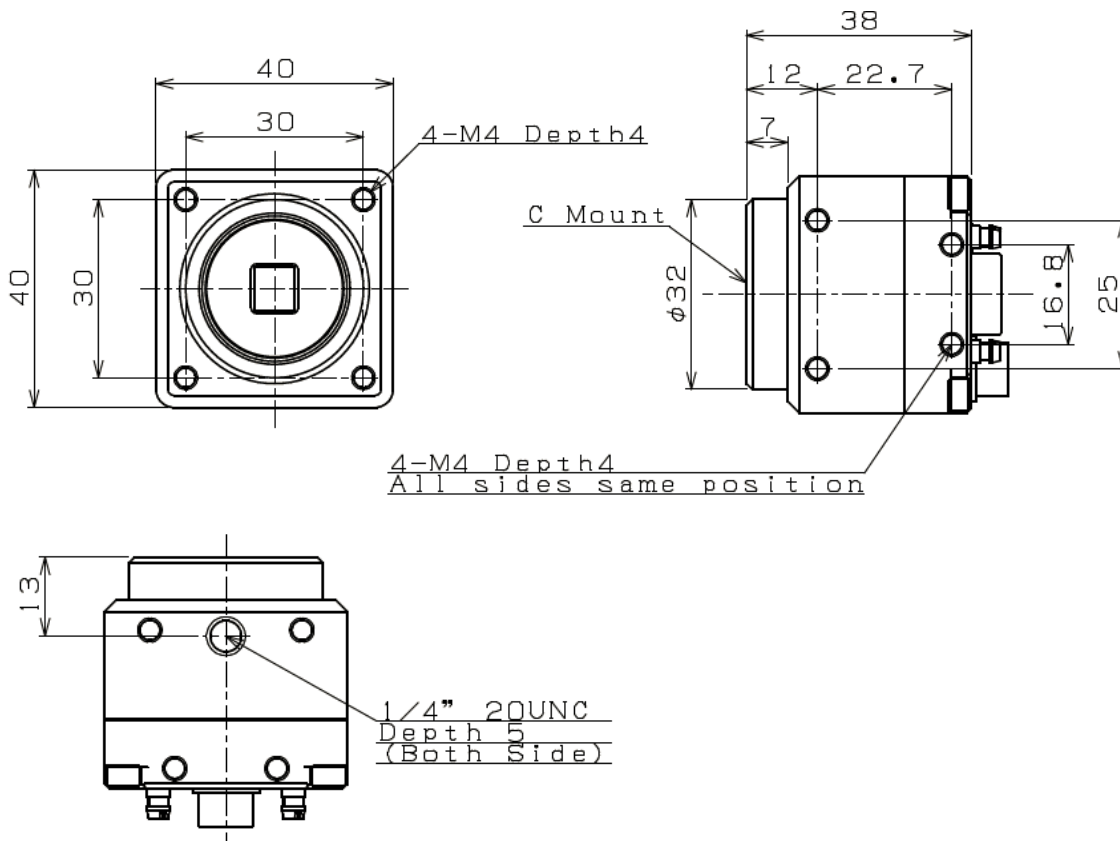

© 4 MP Camera

Dimensions in millimeters.

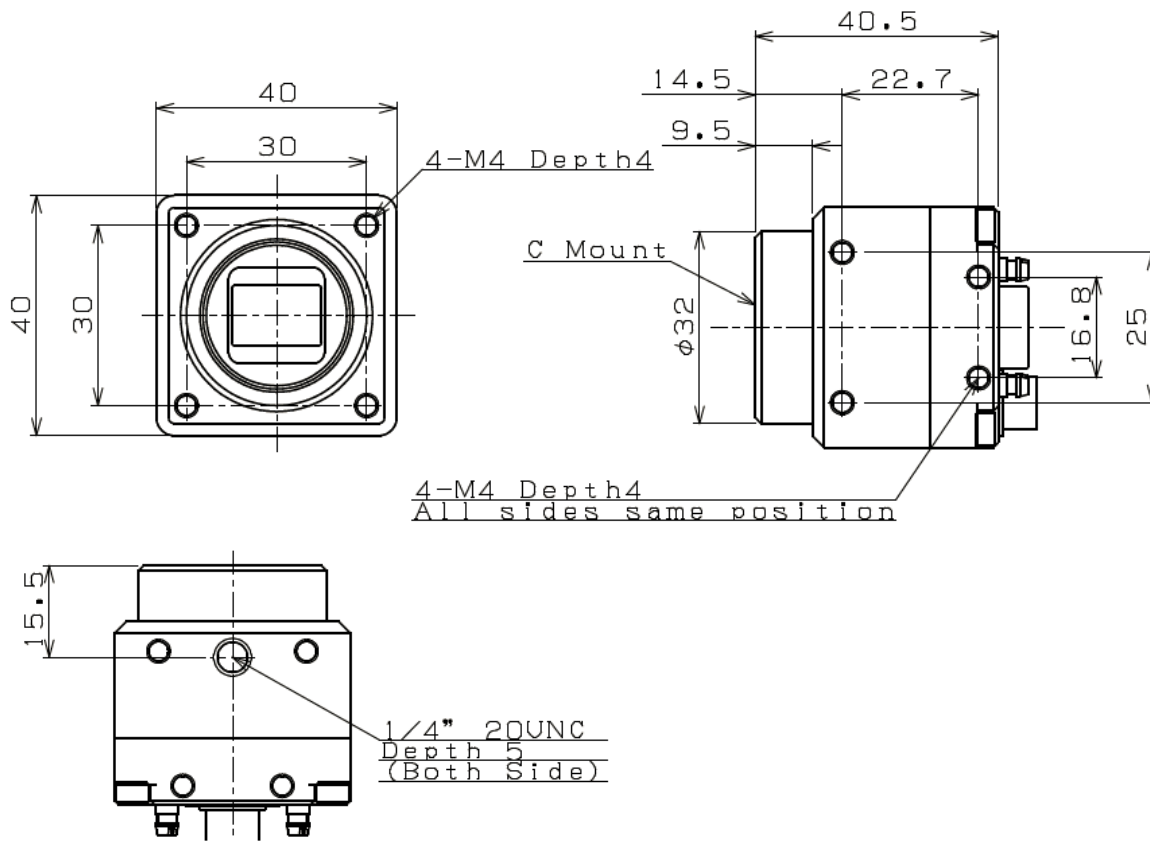

◎ **5 MP Camera**

Dimensions in millimeters.

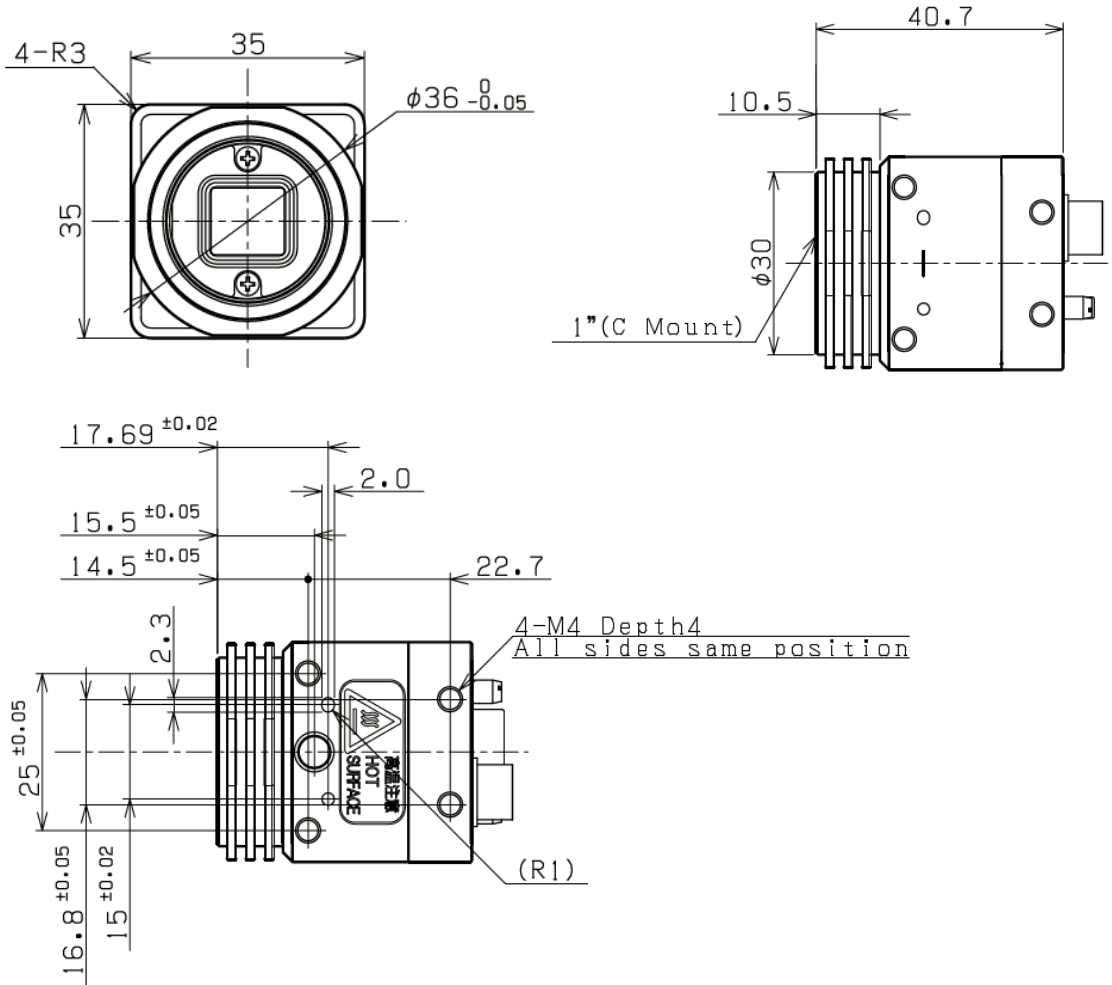

Chapter 1 Components and Specifications

© 12 MP Camera

Dimensions in millimeters.

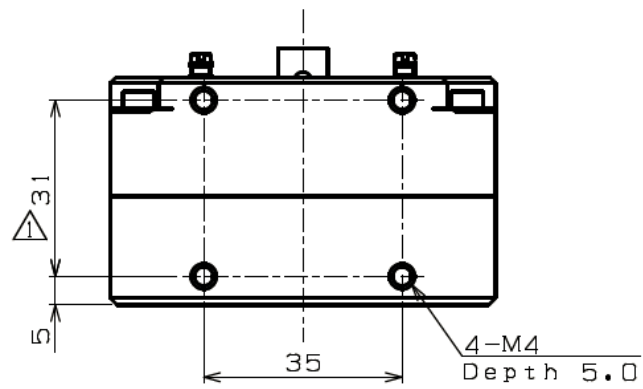
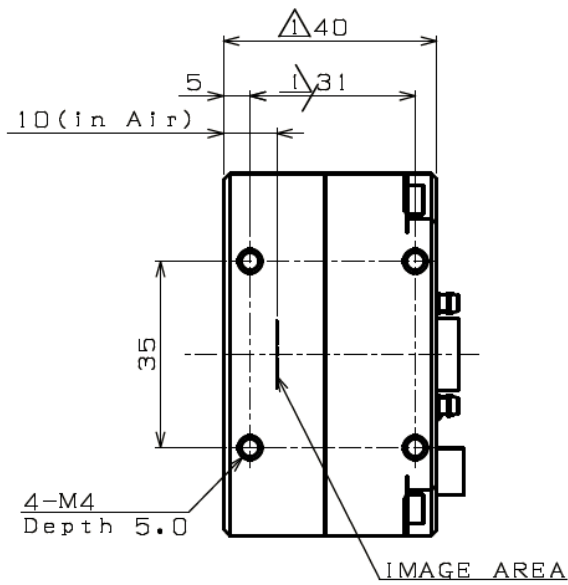
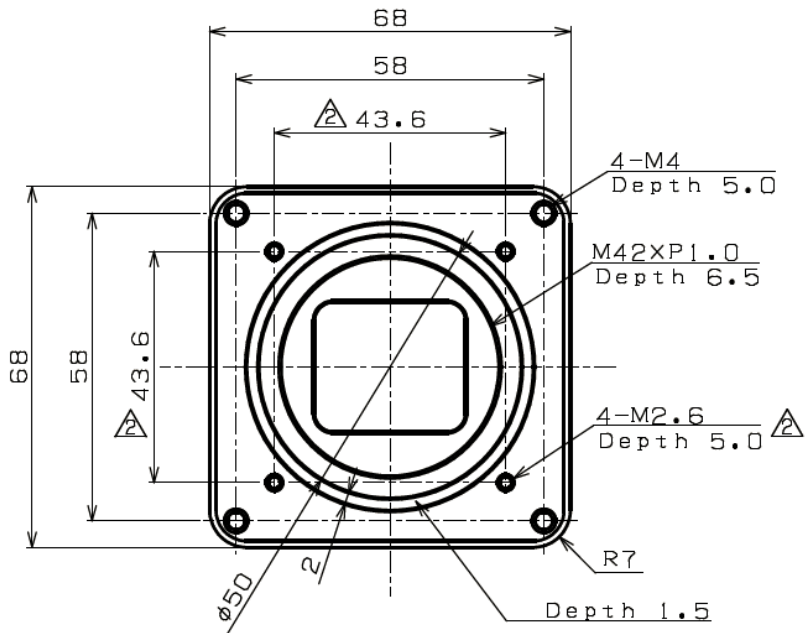

1.3 Camera and Lens Selections

The camera paired with the DMV2000 controller is Camera-Link compatible. Before selecting the lens, please confirm the field of view and working distance between the lens and test object. Refer to the following table for a suitable lens.

Field of view (mm) Horizontal (H) * Vertical (V)	Focal length 6 mm		Focal length 8 mm		Focal length 12mm		Focal length 16mm		Focal length 25mm		Resolution μm/pixel 640 * 480	
	DMV-LN06~100W40 lens (applicable for 0.3 MP camera)											
	Dis.	R	Dis.	R	Dis.	R	Dis.	R	Dis.	R		
1000 (H)*750 (V)	1265	0	1667	0							1562	
800 (H)*600 (V)	1010	0	1333	0	2013	0					1250	
600 (H)*450 (V)	755	0	1000	0	1513	0	2015	0			938	
500 (H)*375 (V)	630	0	833	0	1263	0	1683	0			781	
400 (H)*300 (V)	505	0	667	0	1013	0	1348	0	2181	0	625	
350 (H)*263 (V)	428	0	583	0	888	0	1181	0	1906	0	547	
300 (H)*225 (V)	380	0	500	0	763	0	1014	0	1631	0	469	
250 (H)*188 (V)	310	0	417	0	638	0	847	0	1356	0	391	
225 (H)*169 (V)	278	0	375	0	575	0	764	0	1218	0	352	
200 (H)*150 (V)	248	0	333	0	513	0	681	0	1081	0	313	
175 (H)*131 (V)	210	0	292	0	450	0	597	0	943	0	273	
150 (H)*113 (V)	180	0	244	0	389	0	514	0	806	0	234	
140 (H)*105 (V)	170	0	228	0	362	0	480	0	751	0	219	
130 (H)*98 (V)	155	0	210	0	334	0	444	0	696	0	203	
120 (H)*90 (V)	144	0	193	0	307	0	407	0	641	0	188	
110 (H)*83 (V)	132	0	175	0	280	0	371	0	586	0	172	
100 (H)*75 (V)	116	0	158	0	253	0	336	0	532	0	156	
90 (H)*68 (V)	106	0	142	0	227	0	300	0	477	0	141	
80 (H)*60 (V)	95	0.5	124	0	200	0	265	0	423	0	125	
75 (H)*56 (V)	90	0.5	115	0	183	0	247	0	397	0	117	
70 (H)*53 (V)	84	0.5	107	0	176	0	230	0	370	0	109	
65 (H)*49 (V)	77	0.5	98	0	160	0	212	0	344	0	102	
60 (H)*45 (V)	70	0.5	90	0	147	0	193	1	316	0	94	
55 (H)*41 (V)	64	0.5	81	0.5	133	0	175	1	290	0	86	
50 (H)*38 (V)	58	0.5	72	1	120	0	158	1	262	0	78	
45 (H)*34 (V)	50	0.5	63	1	106	0	142	1.5	235	0	70	
40 (H)*30 (V)	45	0.5	55	1	93	0	123	1.5	208	0	63	

Chapter 1 Components and Specifications

Field of view (mm) Horizontal (H) * Vertical (V)	Focal length 6 mm		Focal length 8 mm		Focal length 12mm		Focal length 16mm		Focal length 25mm		Resolution µm/pixel
	DMV-LN06~100W40 lens (applicable for 0.3 MP camera)										
	Dis.	R	Dis.	R	Dis.	R	Dis.	R	Dis.	R	640 * 480
35 (H)*26 (V)	39	0.5	47	1	79	1	108	1.5	183	1	55
32.5 (H)*24.4 (V)	36	0.5	42	1	72	1	99	2	168	2	51
30.0 (H)*22.5 (V)	31	0.5	37	1.5	66	1.5	89	2	153	2	46.9
27.5 (H)*20.6 (V)			33	1.5	58	1.5	80	2	139	2	43.0
25.0 (H)*18.8 (V)			28	1.5	53	2	72	2	126	2	39.1
22.5 (H)*16.9 (V)			23	2	45	2			111	5	35.2
20.0 (H)*15.0 (V)			19	2	40	2			94	5	31.3
18.0 (H)*13.5 (V)			16	2	33	2			87	5	28.1
17.0 (H)*12.8 (V)			14	2					81	5	26.6
16.0 (H)*12.0 (V)							40	5	76	6	25.0
15.0 (H)*11.3 (V)							36	5	70	6	23.4
14.0 (H)*10.0 (V)					23	5	32	5	64	7	21.9
13.0 (H)*9.8 (V)					21	5	29	6	59	7	20.3
12.0 (H)*9.0 (V)					18	5	25	6	54	8	18.8
11.0 (H)*8.3 (V)					15	5	23	7	49	9	17.2
10.0 (H)*7.5 (V)					13	5	19	8	44	10	15.6
9.0 (H)*6.75 (V)					11	6	16	9	39	11	14.1
8.0 (H)*6.00 (V)					8	7	13	10	34	13	12.5
7.5 (H)*5.63 (V)					8	7	10	10	31	14	11.7
7.0 (H)*5.25 (V)							7	11	27	16	10.9
6.5 (H)*4.88 (V)									25	18	10.2
6.0 (H)*4.50 (V)									23	20	9.38
5.5 (H)*4.13 (V)									21	22	8.59
5.0(H)*3.75 (V)									17	24	7.81
4.5 (H)*3.38 (V)									14	26	7.03
4.0 (H)*3.00 (V)									12	30	6.25
3.5 (H)*2.63 (V)									9	34	5.47

Field of view (mm) Horizontal (H)* Vertical (V)	Focal length 35mm		Focal length 50mm		Focal length 75mm		Focal length 100mm		Resolution µm/pixel	
	DMV-LN06~100W40 lens (applicable for 0.3 MP camera)									
	Dis.	R	Dis.	R	Dis.	R	Dis.	R	640 * 480	

Field of view (mm) Horizontal (H)* Vertical (V)	Focal length 35mm		Focal length 50mm		Focal length 75mm		Focal length 100mm		Resolution µm/pixel 640 * 480
	DMV-LN06~100W40 lens (applicable for 0.3 MP camera)								
	Dis.	R	Dis.	R	Dis.	R	Dis.	R	
300 (H)*225 (V)	2253	0							469
250 (H)*188 (V)	1878	0							391
225 (H)*169 (V)	1690	0							352
200 (H)*150 (V)	1503	0	2241	0					313
175 (H)*131 (V)	1315	0	1963	0					273
150 (H)*113 (V)	1128	0	1686	0					234
140 (H)*105 (V)	1053	0	1575	0					219
130 (H)*98 (V)	978	0	1464	0					203
120 (H)*90 (V)	903	0	1353	0					188
110 (H)*83 (V)	828	0	1242	0					172
100 (H)*75 (V)	753	0	1131	0					156
90 (H)*68 (V)	678	0	1020	0					141
80 (H)*60 (V)	603	0	909	0					125
75 (H)*56 (V)	565	0	853	0					117
70 (H)*53 (V)	528	0	798	0					109
65 (H)*49 (V)	490	0	742	0	1120	5			102
60 (H)*45 (V)	453	0	687	0	1030	5			94
55 (H)*41 (V)	417	0	631	0	954	5			86
50 (H)*38 (V)	378	0	576	0	868	5	1158	5	78
45 (H)*34 (V)	341	1	520	0	794	5	1050	10	70
40 (H)*30 (V)	304	1	465	2	715	5	933	10	63
35 (H)*26 (V)	268	2	409	2	620	5	828	10	55
32.5 (H)*24.4 (V)	247	2	382	5	595	10	780	10	51
30.0 (H)*22.5 (V)	229	2	354	5	536	10	725	15	46.9
27.5 (H)*20.6 (V)	211	2	325	5	508	10	667	15	43.0
25.0 (H)*18.8 (V)	189	5	298	5	470	10	620	15	39.1
22.5 (H)*16.9 (V)	170	5	272	5	427	10	558	20	35.2
20.0 (H)*15.0 (V)	153	5	243	10	384	15	515	20	31.3
18.0 (H)*13.5 (V)	137	5	221	10	353	15	465	25	28.1
17.0 (H)*12.8 (V)	130	5	210	10	338	20	450	25	26.6
16.0 (H)*12.0 (V)	122	5	199	10	324	20	422	25	25.0
15.0 (H)*11.3 (V)	116	5	189	10	309	20	405	30	23.4
14.0 (H)*10.0 (V)	106	10	177	15	289	20	380	30	21.9

Chapter 1 Components and Specifications

Field of view (mm) Horizontal (H)* Vertical (V)	Focal length 35mm		Focal length 50mm		Focal length 75mm		Focal length 100mm		Resolution µm/pixel 640 * 480
	DMV-LN06~100W40 lens (applicable for 0.3 MP camera)								
	Dis.	R	Dis.	R	Dis.	R	Dis.	R	
13.0 (H)*9.8 (V)	99	10	166	15	276	25	362	35	20.3
12.0 (H)*9.0 (V)	92	10	153	15	260	25	335	35	18.8
11.0 (H)*8.3 (V)	85	15	145	15	240	30	320	40	17.2
10.0 (H)*7.5 (V)	77	15	133	20	228	35	300	45	15.6
9.0 (H)*6.75 (V)	68	15	122	20	210	35			14.1
8.0 (H)*6.00 (V)	63	20	111	25					12.5
7.5 (H)*5.63 (V)	58	20	104	25					11.7
7.0 (H)*5.25 (V)	53	20	99	30					10.9
6.5 (H)*4.88 (V)	51	25	92	30					10.2
6.0 (H)*4.50 (V)	46	25	88	35					9.38
5.5 (H)*4.13 (V)	44	30	84	40					8.59
5.0(H)*3.75 (V)	39	30	76	45					7.81
4.5 (H)*3.38 (V)	35	35	72	50					7.03
4.0 (H)*3.00 (V)	33	40	66	55					6.25
3.5 (H)*2.63 (V)	27	45	60	65					5.47

Field of view (mm) Horizontal (H)* Vertical (V)	Focal length 5mm		Focal length 8 mm		Focal length 12mm		Focal length 16mm		Focal length 25mm		Resolution µm/pixel 2000*1000
	DMV-LN06~50M lens (applicable for 2 MP camera)										
	Dis.	R	Dis.	R	Dis.	R	Dis.	R	Dis.	R	
1000 (H)*500 (V)	415	0	715	0	1120	0					500
800 (H)*400 (V)	325	0	555	0	900	0	1175	0			400
600 (H)*300 (V)	240	0	410	0	630	0	880	0			300
500 (H)*250 (V)	198	0	335	0	525	0	730	0	1150	0	250
400 (H)*200 (V)	158	0	265	0	416	0	545	0	920	0	200
350 (H)*175 (V)	135	0	232	0	360	0	476	0	800	0	175
300 (H)*150 (V)	116	0	200	0	310	0	408	0	646	0	150
250 (H)*125 (V)	92	0	166	0	254	0	340	0	535	0	125
225 (H)*112 (V)	84	0	145	0	227	0	304	0	480	0	112
200 (H)*100 (V)	74	0	130	0	202	0	270	0	426	0	100
175 (H)*82.5 (V)	58	0	105	0.5	164	0	215	0	350	0	82.5
150 (H)*75 (V)	51	0	91	0.5	150	0	200	0	320	0	75

Field of view (mm) Horizontal (H)* Vertical (V)	Focal length 5mm		Focal length 8 mm		Focal length 12mm		Focal length 16mm		Focal length 25mm		Resolution μm/pixel
	DMV-LN06~50M lens (applicable for 2 MP camera)										
	Dis.	R	Dis.	R	Dis.	R	Dis.	R	Dis.	R	2000*1000
140 (H)*70 (V)	47	0	85	0.5	138	0	187	0.5	298	0	70
130 (H)*65 (V)	43	0	78	0.5	127	0.5	170	0.5	277	0	65
120 (H)*60 (V)	38	0	71	0.5	115	0.5	156	1	255	0	60
110 (H)*55 (V)	34	0	62	1	107	0.5	144	1	235	0	55
100 (H)*50 (V)			57	1	95	1	130	1.5	214	0	50
90 (H)*45 (V)			50	1	86	1	115	1.5	189	1	45
80 (H)*40 (V)			44	1	72	1	100	2	166	1	40
75 (H)*37.5 (V)			39	1	66	2	92	2	153	2	37.5
70 (H)*35 (V)			35	1	61	2	85	2	145	2	35
65 (H)*32.5 (V)					56	2			135	2	32.5
60 (H)*30 (V)					51	2			123	2	30
55 (H)*27.5 (V)					45	2			110	5	27.5
50 (H)*25 (V)									100	5	25
45 (H)*22.5 (V)							47	5	87	5	22.5
40 (H)*20 (V)							43	5	78	5	20
35 (H)*17.5 (V)							34	5	66	7	17.5
32.5 (H)*16.2 (V)									62	7	16.25
30.0 (H)*15.0 (V)									57	10	15
27.5 (H)*13.7 (V)									49	10	13.75
25.0 (H)*12.5 (V)									45	10	12.5

Field of view (mm) Horizontal (H)* Vertical (V)	Focal length 35mm		Focal length 50mm		Resolution μm/pixel
	DMV-LN06~50M lens (applicable for 2 MP camera)				
	Dis.	R	Dis.	R	2000*1000
350 (H)*175 (V)	1120	0			175
300 (H)*150 (V)	938	0			150
250 (H)*125 (V)	788	0	1200	0	125
225 (H)*112 (V)	715	0	1070	0	112
200 (H)*100 (V)	602	0	964	0	100
175 (H)*82.5 (V)	500	0	855	0	82.5
150 (H)*75 (V)	458	0	735	0	75

Chapter 1 Components and Specifications

Field of view (mm) Horizontal (H)* Vertical (V)	Focal length 35mm		Focal length 50mm		Resolution μm/pixel
	DMV-LN06~50M lens (applicable for 2 MP camera)				
	Dis.	R	Dis.	R	
					2000*1000
140 (H)*70 (V)	427	0	660	0	70
130 (H)*65 (V)	400	0	600	0	65
120 (H)*60 (V)	368	0	555	0	60
110 (H)*55 (V)	342	0	510	0	55
100 (H)*50 (V)	312	0	468	0	50
90 (H)*45 (V)	280	0	425	0	45
80 (H)*40 (V)	246	0	378	0	40
75 (H)*37.5 (V)	230	0	355	0	37.5
70 (H)*35 (V)	218	0	338	0	35
65 (H)*32.5 (V)	204	0	318	0	32.5
60 (H)*30 (V)	190	1	294	0	30
55 (H)*27.5 (V)	172	2	270	0	27.5
50 (H)*25 (V)	156	5	250	0	25
45 (H)*22.5 (V)	138	5	225	0	22.5
40 (H)*20 (V)	125	5	203	0	20
35 (H)*17.5 (V)	111	10	180	5	17.5
32.5 (H)*16.2 (V)	104	10	174	5	16.25
30.0 (H)*15.0 (V)	95	10	160	5	15
27.5 (H)*13.7 (V)	88	15	150	10	13.75
25.0 (H)*12.5 (V)	82	15	138	10	12.5
22.5 (H)*11.2 (V)	74	15	131	15	11.25
20.0 (H)*10.0 (V)	68	15	117	20	10
18.0 (H)*9.0 (V)			105	30	9
17.0 (H)*8.5 (V)			100	30	8.5
16.0 (H)*8.0 (V)			95	30	8
15.0 (H)*7.5 (V)			90	30	7.5

Field of view (mm) Horizontal (H) * Vertical (V)	Focal length 12mm		Focal length 16mm		Focal length 25mm		Focal length 35mm		Focal length 50mm		Resolution μm/pixel
	DMV-LN12~50M06 lens (applicable for 4 MP camera)										
	Dis.	R	Dis.	R	Dis.	R	Dis.	R	Dis.	R	
1000 (H)*1000 (V)	1120	0									2000*2000
											500

Field of view (mm) Horizontal (H) * Vertical (V)	Focal length 12mm		Focal length 16mm		Focal length 25mm		Focal length 35mm		Focal length 50mm		Resolution µm/pixel
	DMV-LN12~50M06 lens (applicable for 4 MP camera)										
	Dis.	R	Dis.	R	Dis.	R	Dis.	R	Dis.	R	2000*2000
800 (H)*800 (V)	900	0	1175	0							400
600 (H)*600 (V)	630	0	880	0							300
500 (H)*500 (V)	525	0	730	0	1150	0					250
400 (H)*400 (V)	416	0	545	0	920	0					200
350 (H)*350 (V)	360	0	476	0	800	0	1125	0			175
300 (H)*300 (V)	310	0	408	0	646	0	950	0			150
250 (H)*250 (V)	254	0	340	0	535	0	790	0	1146	0	125
225 (H)*225 (V)	227	0	304	0	478	0	706	0	1038	0	112
200 (H)*200 (V)	202	0	270	0	424	0	635	0	933	0	100
175 (H)*175 (V)	164	0	215	0	348	0	560	0	820	0	82.5
150 (H)*150 (V)	150	0	200	0	318	0	480	0	735	0	75
140 (H)*140 (V)	138	0	187	0.5	295	0	444	0	655	0	70
130 (H)*130 (V)	127	0.5	170	0.5	274	0	408	0	610	0	65
120 (H)*120 (V)	115	0.5	156	1	253	0	375	0	565	0	60
110 (H)*110 (V)	107	0.5	144	1	233	0	342	0	515	0	55
100 (H)*100 (V)	95	1	130	1.5	212	0	312	0	478	0	50
90 (H)*90 (V)	86	1	115	1.5	186	1	280	0	428	0	45
80 (H)*80 (V)	72	1	100	2	162	1	246	0	380	0	40
75 (H)*75 (V)	66	2	92	2	149	2	230	0	357	0	37.5
70 (H)*70 (V)	61	2	85	2	140	2	218	0	339	0	35
65 (H)*65 (V)	56	2			128	2	204	0	319	0	32.5
60 (H)*60 (V)	51	2			118	2	190	1	294	0	30
55 (H)*55 (V)	45	2			105	5	172	2	270	1	27.5
50 (H)*50 (V)					95	5	158	5	253	5	25
45 (H)*45 (V)			47	5	82	5	145	5	225	5	22.5
40 (H)*40 (V)			43	5	72	5	130	5	203	5	20
35 (H)*35 (V)			34	5	61	7	114	10	184	10	17.5
32.5 (H)*32.5 (V)					57	7	104	10	172	10	16.25
30.0 (H)*30.0 (V)					51	10	95	10	160	15	15
27.5 (H)*27.5 (V)					43	10	88	15	150	20	13.75
25.0 (H)*25.0 (V)					39	10	82	15	138	20	12.5
22.5 (H)*22.5 (V)							74	15	127	25	11.25
20.0 (H)*20.0 (V)							68	15	116	25	10.0

Chapter 1 Components and Specifications

Field of view (mm) Horizontal (H) * Vertical (V)	Focal length 12mm		Focal length 16mm		Focal length 25mm		Focal length 35mm		Focal length 50mm		Resolution μm/pixel
	DMV-LN12~50M06 lens (applicable for 4 MP camera)										
	Dis.	R	Dis.	R	Dis.	R	Dis.	R	Dis.	R	2000*2000
18.0 (H)*18.0 (V)									105	30	9.0
17.0 (H)*17.0 (V)									100	30	8.5
16.0 (H)*16.0 (V)									95	30	8.0
15.0 (H)*15.0 (V)									90	30	7.5
14.0 (H)*14.0 (V)									85	40	7.0

Field of view (mm) Horizontal (H) * Vertical (V)	Focal length 12mm		Focal length 35mm		Focal length 50mm		Resolution μm/pixel
	DMV-LN12~50M05 lens (applicable for 4 MP camera)						
	Dis.	R	Dis.	R	Dis.	R	2000*2000
1000 (H)*1000 (V)	1050	0					500
800 (H)*800 (V)	835	0					400
600 (H)*600 (V)	625	0					300
500 (H)*500 (V)	535	0					250
400 (H)*400 (V)	422	0					200
350 (H)*350 (V)	372	0	1105	0			175
300 (H)*300 (V)	303	0	954	0			150
250 (H)*250 (V)	246	0	790	0	1108	0	125
225 (H)*225 (V)	217	0	712	0	992	0	112
200 (H)*200 (V)	194	0	630	0	888	0	100
175 (H)*175 (V)	167	0	538	0	773	0	82.5
150 (H)*150 (V)	138	0	465	0	655	0	75
140 (H)*140 (V)	128	0	430	0	615	0	70
130 (H)*130 (V)	119	0	402	0	560	0	65
120 (H)*120 (V)	108	0	367	0	520	0	60
110 (H)*110 (V)	98	0	336	0	478	0	55
100 (H)*100 (V)	86	0	308	0	435	0	50
90 (H)*90 (V)	79	2	278	0	390	0	45
80 (H)*80 (V)	68	2	246	0	345	0	40
75 (H)*75 (V)	61	2	230	0	320	0	37.5
70 (H)*70 (V)	55	2	216	0	297	0	35
65 (H)*65 (V)	50	2	198	0	278	0	32.5

Field of view (mm) Horizontal (H) * Vertical (V)	Focal length 12mm		Focal length 35mm		Focal length 50mm		Resolution µm/pixel
	DMV-LN12~50M05 lens (applicable for 4 MP camera)						
	Dis.	R	Dis.	R	Dis.	R	
60 (H)*60 (V)	44	2	178	5	250	5	30
55 (H)*55 (V)	38	2	164	5	230	5	27.5
50 (H)*50 (V)			147	5	210	5	25
45 (H)*45 (V)			134	5	189	5	22.5
40 (H)*40 (V)			115	5	158	10	20
35 (H)*35 (V)			100	10	138	10	17.5
32.5 (H)*32.5 (V)			92	10	129	10	16.25
30.0 (H)*30.0 (V)			86	10	120	15	15
27.5 (H)*27.5 (V)			80	10	100	20	13.75
25.0 (H)*25.0 (V)			66	15	90	20	12.5
22.5 (H)*22.5 (V)			60	15	84	20	11.25
20.0 (H)*20.0 (V)			55	15	70	25	10.0
18.0 (H)*18.0 (V)					60	30	9.0

Remark Dis. is the working distance and R is the size of the extension circle.

Increasing depths of field increases the range of focus. The following characteristics affect the depth of field:

- Longer extension circles results in shallower depths of field; thus the depth of field increases when using shorter extension circles.
- Longer working distance results in a deeper depth of field.
- Smaller aperture results in a deeper depth of field.
- Shorter focal length of the lens results in a deeper depth of field.

1.4 Grounding and Installation

1.4.1 Grounding

Caution:

- 1) Do not connect or disconnect the wires while system is powered on.
- 2) The grounding wire should be the minimum length using the wire gauge specified by relevant laws and regulations. The grounding resistance must be under 100 Ω .
- 3) Please ground the DMV controller separately from other devices. Do not directly connect to other power devices.

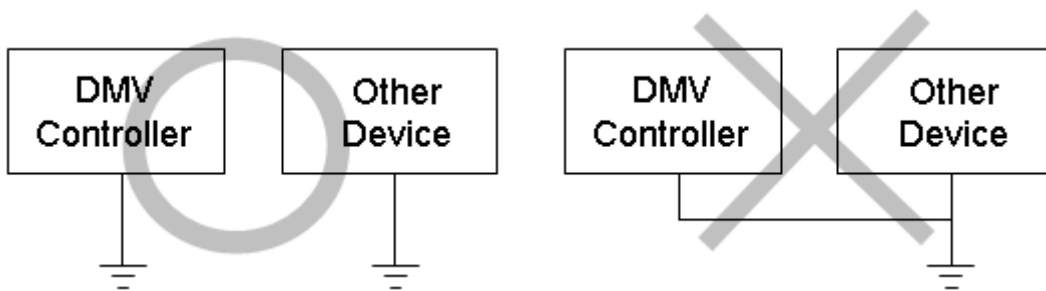

1.4.2 Installation

The DMV system provides DIN rail installation

- Installation method (must be installed in standard 35-mm rail groove)
 - 1) Place the controller unit onto the aluminum rails.
 - 2) Gently push down on the controller and slide it into place on the aluminum rails.
- Disassembly
 - 1) Insert the screwdriver into the DIN rail latch.
 - 2) Push down on the holding latch to release the controller and then remove it.

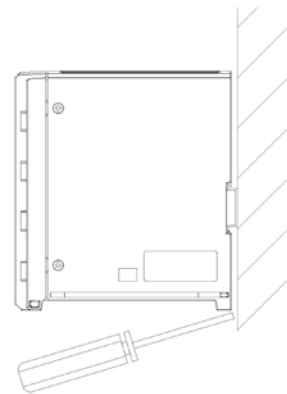
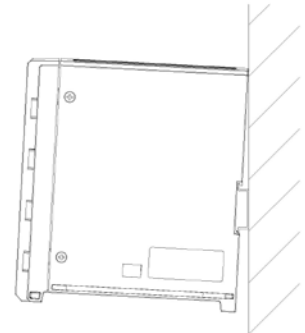

Please keep at least 50 mm above and 30 mm to the left and right of the controller for proper ventilation. Excessive operating temperature due to insufficient cooling will damage the controller. Please keep at least 100 mm of space in front of the wiring panel for ease of access.

Chapter 2

Input and Output Interface

The DMV input and output interfaces include the following:

- I/O terminal
- RS232
- RS485
- Ethernet
- MicroSD card

The pins and wiring connections are defined and detailed below.

2.1 Input / Output (I/O) Terminal Block

The input/output terminals are 9 pin (input) and 12 pin (output) removable terminals. The contact functions and default values are defined in the following picture. You can define each input/output function according to your needs.

- ▶ On the DMV2000 terminal, in the Main window, click **System**, then click **Communication**, then click **Device Setting**, and finally click **External Terminal**.

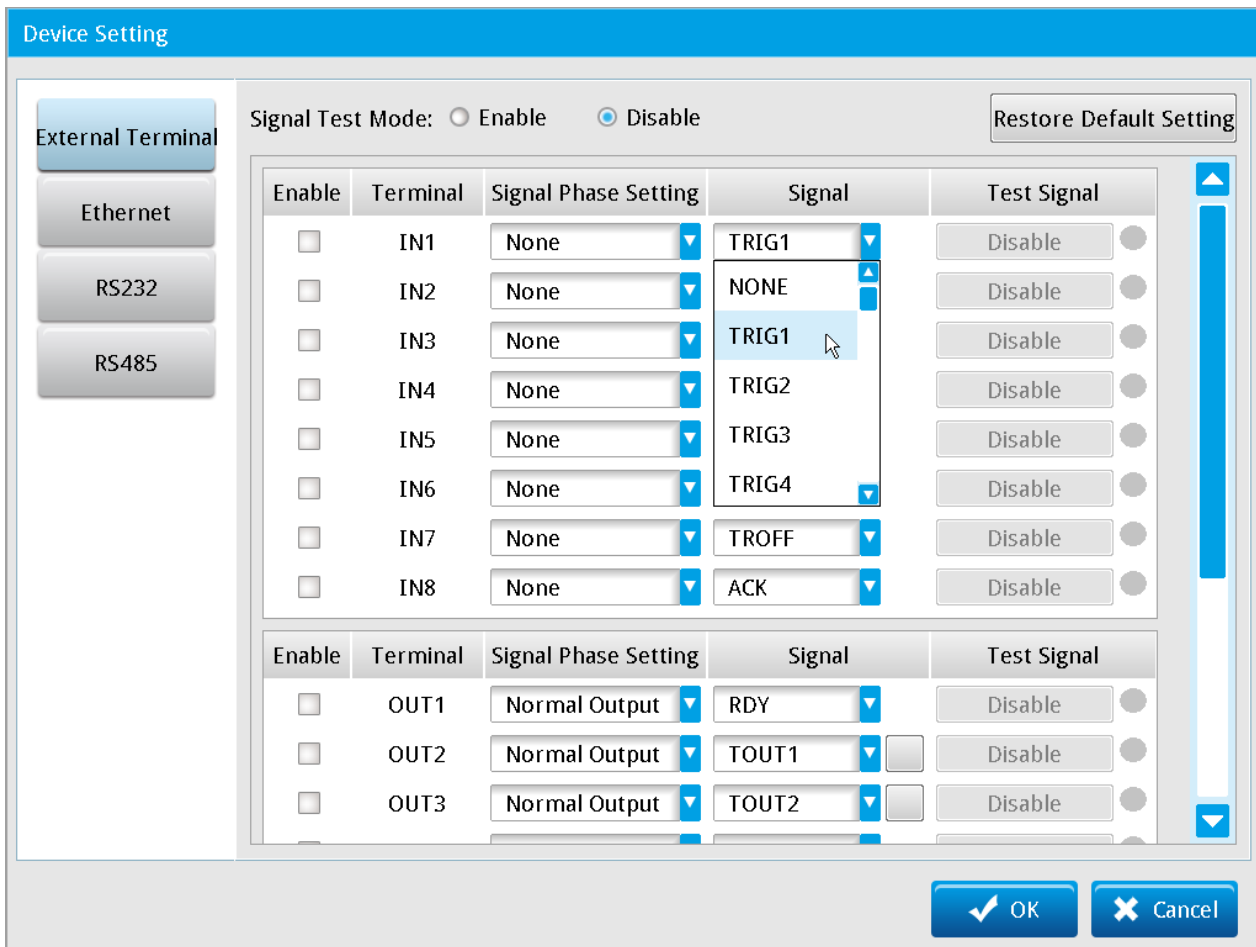

 **Reference** Please refer to Chapter 7 for the purpose and sequence of each terminal.

2.1.1 9-Pin Input Terminal

The following table lists the input functions with the default values, and can be changed according to your application.

Serial No.	Name	Description
1	COMIN	9-pin input common contact (NPN/PNP selection)
2	IN1	TRIG1: Camera 1 capture trigger
3	IN2	TRIG2: Camera 2 capture trigger
4	IN3	TRIG3: Camera 3 capture trigger
5	IN4	TRIG4: Camera 4 capture trigger
6	IN5	TEST: test status (no inspection results are generated in the output)
7	IN6	PLINK: PLC data link communication startup flag
8	IN7	TROFF: trigger disabled (inspection disabled)
9	IN8	ACK: parallel output handshake flag

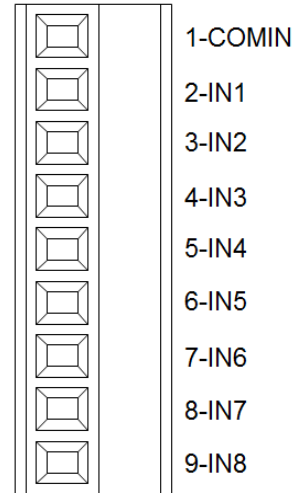

◆ **Input schematic (NPN input)**

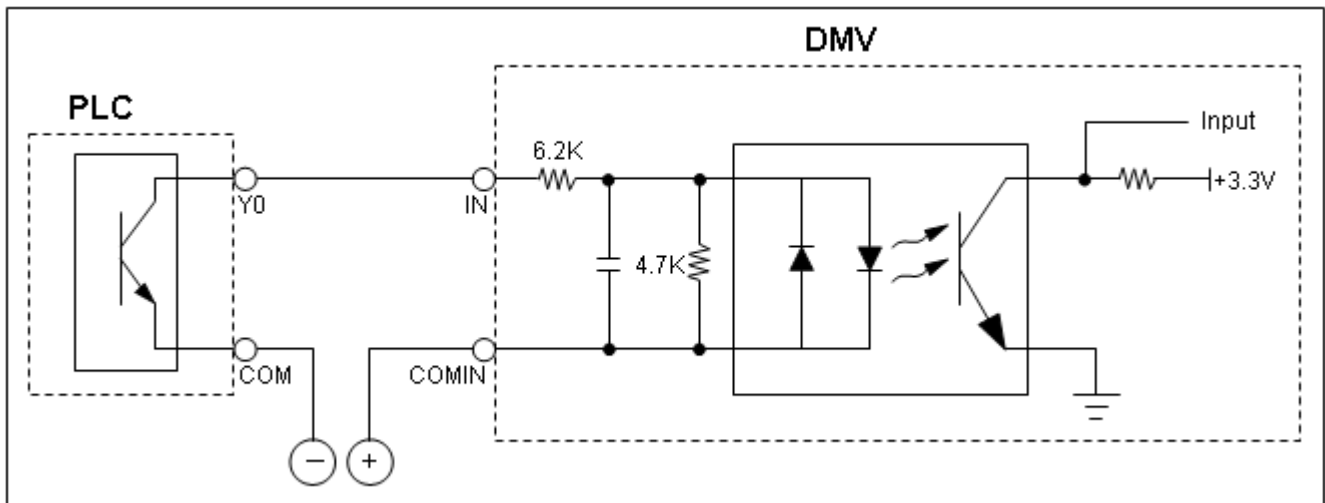

◆ Input schematic (PNP input)

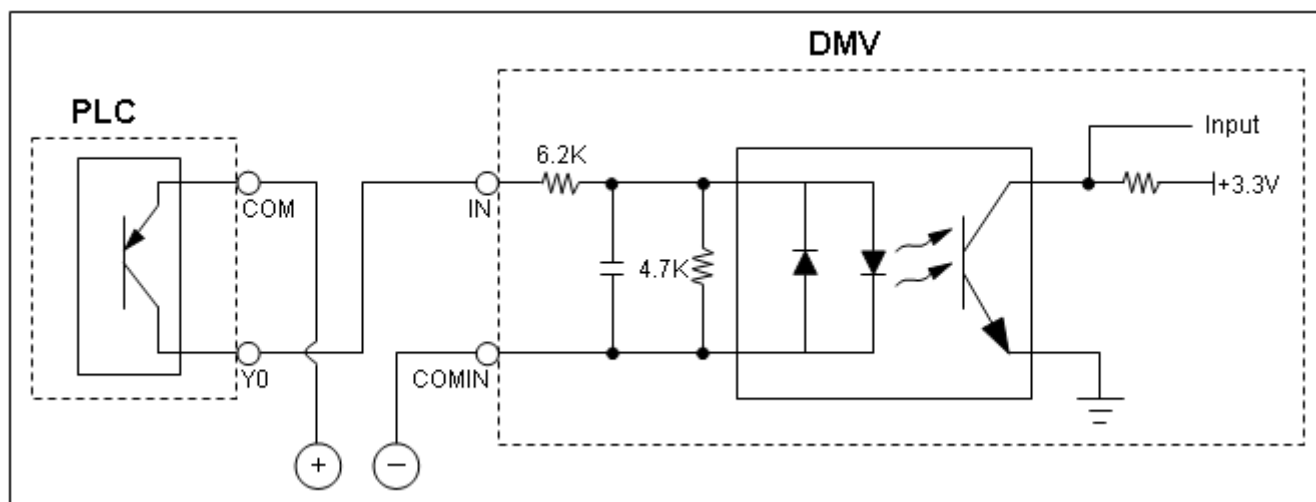

2.1.2 12-Pin Output Terminal

The following table lists the output functions with the default values, which can be changed according to your application.

Serial No.	Name	Description
1	OUT1	RDY: controller in standby waiting for image capture and output inspection
2	OUT2	TOUT1: Total Judged result output 1
3	OUT3	TOUT2: Total Judged result output 2
4	OUT4	ERR: error status indicator
5	OUT5	STR: parallel output handshake flag
6	OUT6	REND1: Camera 1 capture complete
7	OUT7	REND2: Camera 2 capture complete
8	OUT8	REND3: Camera 3 capture complete
9	OUT9	REND4: Camera 4 capture complete
10	OUT10	FLH1: Camera 1 light source strobe control output
11	OUT11	FLH2: Camera 2 light source strobe control output
12	COMOUT	12-pin output common contact (connect the negative terminal of the power source for the NPN output method).

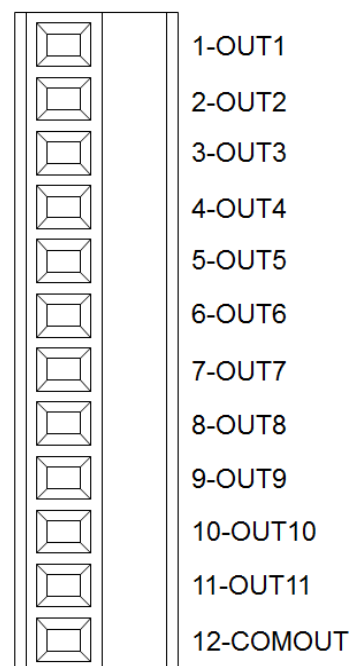

◆ **Normal output circuit diagram (fixed to NPN output)**

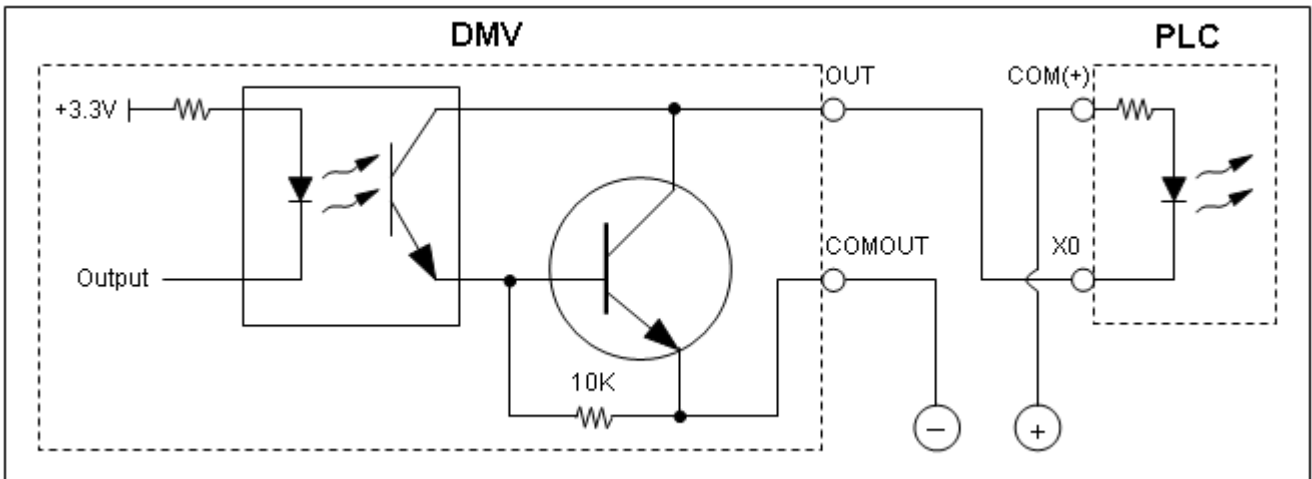

◆ **Light source dimmer strobe control output circuit diagram (fixed to NPN output)**

You must connect a 10 KΩ resistor to the 24 V positive terminal of the power supply. Using a resistor with the wrong impedance does not result in damage to the I/O terminals on the DMV system, but may cause the light strobes to malfunction.

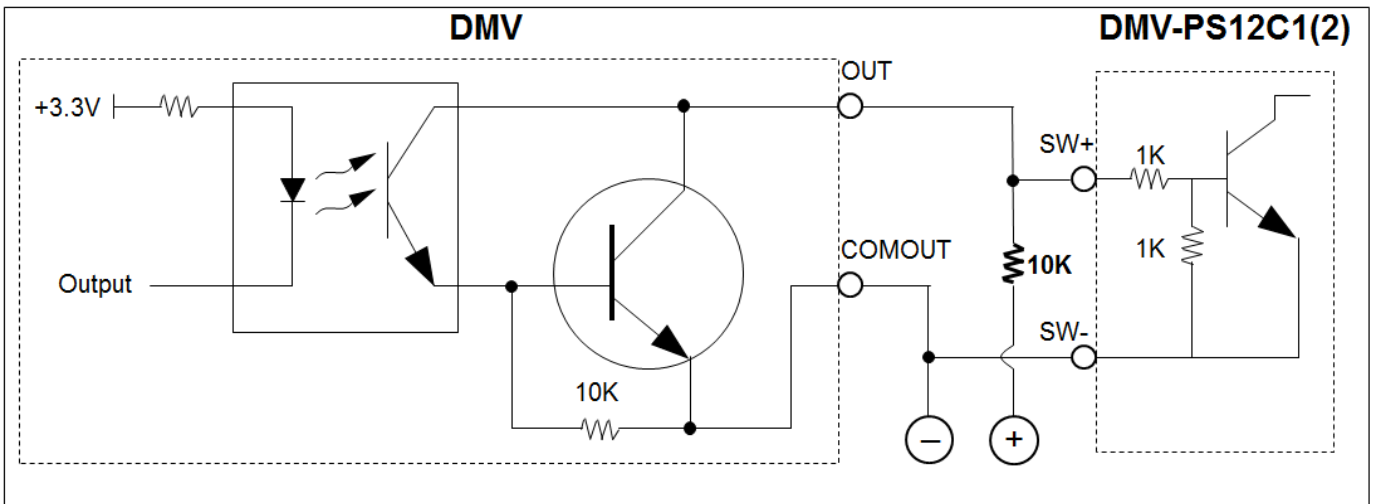

2.1.3 Input / Output Contacts Descriptions

The following table lists the input and output connection as described in sections 2.1.1 and 2.1.2.

Name	Description	Mode
TRIG1	Camera 1 trigger capture	Input
TRIG2	Camera 2 trigger capture	Input
TRIG3	Camera 3 trigger capture	Input
TRIG4	Camera 4 trigger capture	Input
TEST	Test status (results are not generated in the output)	Input
PLINK	PLC data link communication startup flag	Input
TROFF	Trigger disabled (inspection disabled)	Input
ACK	Parallel output handshake flag	Input
IN1	Number input 1	Input
IN2	Number input 2	Input
IN3	Number input 3	Input
IN4	Number input 4	Input
IN5	Number input 5	Input
IN6	Number input 6	Input
IN7	Number input 7	Input
IN8	Number input 8	Input
FNC1	Function Selection 1	Input
FNC2	Function Selection 2	Input
FNC3	Function Selection 3	Input
FNC4	Function Selection 4	Input
FNC5	Function Selection 5	Input
FNC6	Function Selection 6	Input
FNC7	Function Selection 7	Input
FNC8	Function Selection 8	Input
FCH	Function select trigger	Input
IACK	Communication output handshake flag	Input
RST	System reset	Input

Name	Description	Mode
READY1	Controller ready output indicator 1	Output
READY2	Controller ready output indicator 2	
READY3	Controller ready output indicator 3	
READY4	Controller ready output indicator 4	
TOUT1	Total Judged result output 1	Output
TOUT2	Total Judged result output 2	Output
ERR	Error status indicator	Output
STR	Parallel output handshake flag	Output
REND1	Camera 1 captured	Output
REND2	Camera 2 captured	Output
REND3	Camera 3 captured	Output
REND4	Camera 4 captured	Output
FLH1	Camera 1 light source strobe control output	Output
FLH2	Camera 2 light source strobe control output	Output
FLH3	Camera 3 light source strobe control output	Output
FLH4	Camera 4 light source strobe control output	Output
SW	Function switching success flag	Output
NSW	Function switching failed flag	Output
FRDY	Allow function switching flag	Output
OUT1	Parallel output 1	Output
OUT2	Parallel output 2	Output
OUT3	Parallel output 3	Output
OUT4	Parallel output 4	Output
OUT5	Parallel output 5	Output
OUT6	Parallel output 6	Output
OUT7	Parallel output 7	Output
OUT8	Parallel output 8	Output
OUT9	Parallel output 9	Output
OUT10	Parallel output 10	Output
OUT11	Parallel output 11	Output
OUT12	Parallel output 12	Output
OUT13	Parallel output 12	Output
OUT14	Parallel output 14	Output
OUT15	Parallel output 15	Output
OUT16	Parallel output 16	Output

2.2 RS232/RS485 Serial Output

The system includes both RS232 and RS485 serial communication interfaces. The two interfaces operate independently and you can configure different baud rates and protocols for each serial port.

- On the DMV2000 terminal in the Main window, click **System**, click **Communication**, then click **Device Setting**, and finally click **RS232** and **RS485**.

Select the DMV2000's communication station number in the RS485 settings (**ID**).

The screenshot shows the 'Device Setting' window with the 'RS232' tab selected. The settings are as follows:

Setting	Value
Baud Rate:	9600
Stop Bit:	<input checked="" type="radio"/> 1 <input type="radio"/> 2
Parity Bit:	<input type="radio"/> None <input type="radio"/> Odd <input checked="" type="radio"/> Even
Data Bit:	<input checked="" type="radio"/> 7-bit <input type="radio"/> 8-bit

The screenshot shows the 'Device Setting' window with the 'RS485' tab selected. The settings are as follows:

Setting	Value
Baud Rate:	9600
Stop Bit:	<input checked="" type="radio"/> 1 <input type="radio"/> 2
Parity Bit:	<input type="radio"/> None <input type="radio"/> Odd <input checked="" type="radio"/> Even
Data Bit:	<input checked="" type="radio"/> 7-bit <input type="radio"/> 8-bit
ID:	1

2.2.1 RS232/RS485 Pins

◎ RS232

The DMV can connect directly to the PC master when you set the DMV to slave mode.

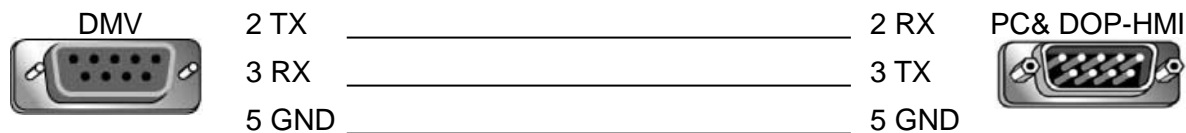

You must reverse RX and TX when connecting to a Delta PLC (using the COM3 RS232 expansion card), because the DMV and the PLC are both set to slave mode.

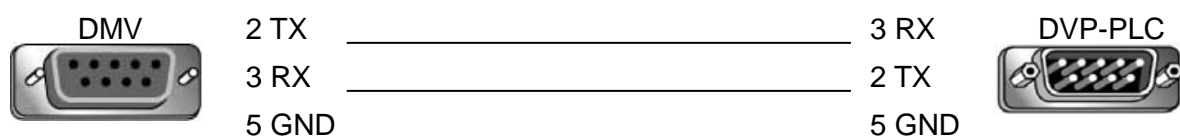

◎ RS485

The main DMV2000 unit has a three-wire RS485 port, which is capable of executing one-to-many communication. When making wire connections, you can directly connect D+ and D- to the D+ and D- terminals on the component.

2.3 Ethernet Output

The DMV2000 Ethernet port uses the TCP/IP communication protocol.

- Configure the IP location of the unit. In the Main window, click **System**, click **Communication**, then click **Device Setting**, and finally click **Ethernet**.

The screenshot shows the 'Device Setting' window with the 'Ethernet' tab selected. The configuration fields are as follows:

External Terminal	IP Version:	<input checked="" type="radio"/> IPv4			
Ethernet	IP Address:	192	168	1	2
RS232	Subnet Mask:	255	255	255	0
RS485	Default Gateway:	192	168	1	1
	Port:	502			
	MAC Address:	D0 : 39 : 72 : 07 : 6D : 94			

2.4 MicroSD Card

The unit supports MicroSD cards of up to 32 GB capacity for storing more projects and image files than you can store in the DMV internal memory.

⊙ Expansion for the Number of Projects

The system memory is limited, but you can use a MicroSD card to expand the number of stored projects. You can select whether to store a project in the internal memory (**NAND**) or the MicroSD card (**SD Card**) when adding a new project.

The screenshot shows the 'Add Project' dialog box with the following fields and options:

- Project Name:
- Parallel Flow Number:
- Device Choose: NAND SD Card

⊙ Storage for Inspection Image Files

You can also use a MicroSD card to store the images from the inspection process for later analysis.

Chapter 3

Basic Operation

The DMV2000 uses both a mouse and keyboard to operate the system. This chapter explains the software functions and project setup, including the Main window, Tool settings, and System settings.

3.1 Main Page

The following picture shows the Main window when you start the DMV2000 controller. Each feature is explained below.

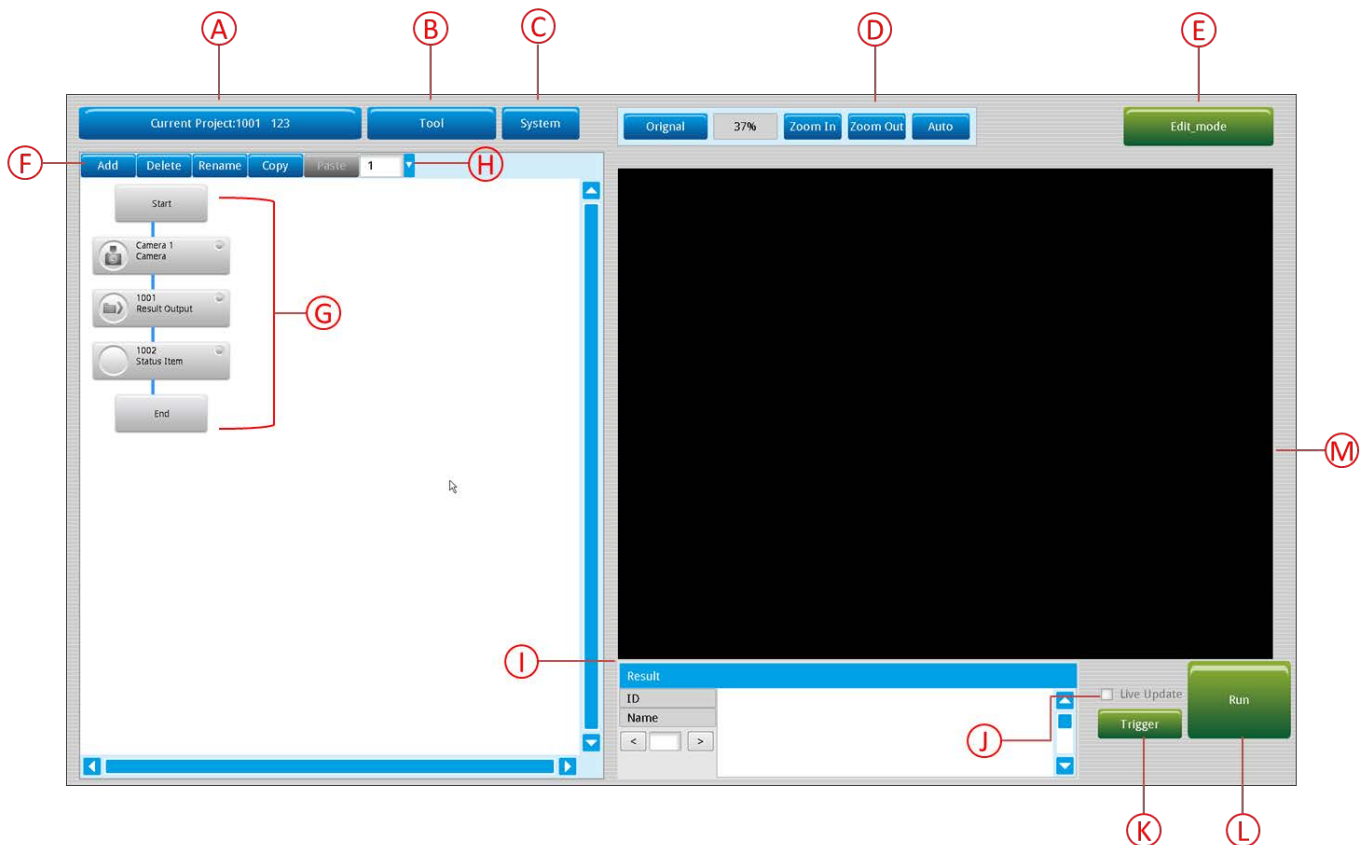

A. Current Project

The name of the project you are currently configuring. Click this button to edit the current project settings or create a new project.

B. Tool

Displays a menu with commands to configure the settings for the project. These include **Register Image Management**, **Screen Editing**, and **Judge Setting**.

 **Reference** Please refer to Section 3.3 for the details of the Tool Settings.

C. System

The System settings consists of several configuration functions, including **General Setting**, **Camera Setting**, **Communication Setting**, **Display Setting**, **Environment Setting**, **Security Setting**, and **Software Update**.

 **Reference** Please refer to Section 3.4 for the details of the System settings.

D. Zoom In, Zoom Out, Auto

These adjust the camera capture screen.

E. Editing Mode

Click this button to change to Edit mode to edit the current project settings.

F. Add, Delete, Rename, Copy, Paste

A single inspection process may contain several inspections. These commands add, delete, rename, copy, and paste the individual inspections within the inspection process.

G. Inspection (Flow) Process

A complete inspection process includes camera, inspection, result output, and status items.

Add: Adds 1 inspection.

Delete: Deletes the selected inspection.

Rename: Renames the selected inspection.

Copy: Copies the selected inspection.

Paste: Pastes the copied inspection.

H. Parallel Flow Number

You can configure up to a maximum of 8 inspection processes as needed for a single inspection project.

This control displays the current inspection flow number.

I. Result

Displays the inspection results.

J. Live Update

When configuring the camera, select this check box to display the live image from the camera to check the configuration.

K. Trigger

Click Trigger when editing a project to capture the image from the camera.

L. Run

Click Run to enter Run mode after you finish editing the project settings.

M. Camera Capture Screen

Displays the images from the flow process cameras when they are capturing images.

3.2 Project Setup

Project setup is the first step when creating a new project. All subsequent inspection settings are stored according in the current project. Click the **Project Setting** button (displays the project name) on the Main window to display the **Project Setting** dialog box.

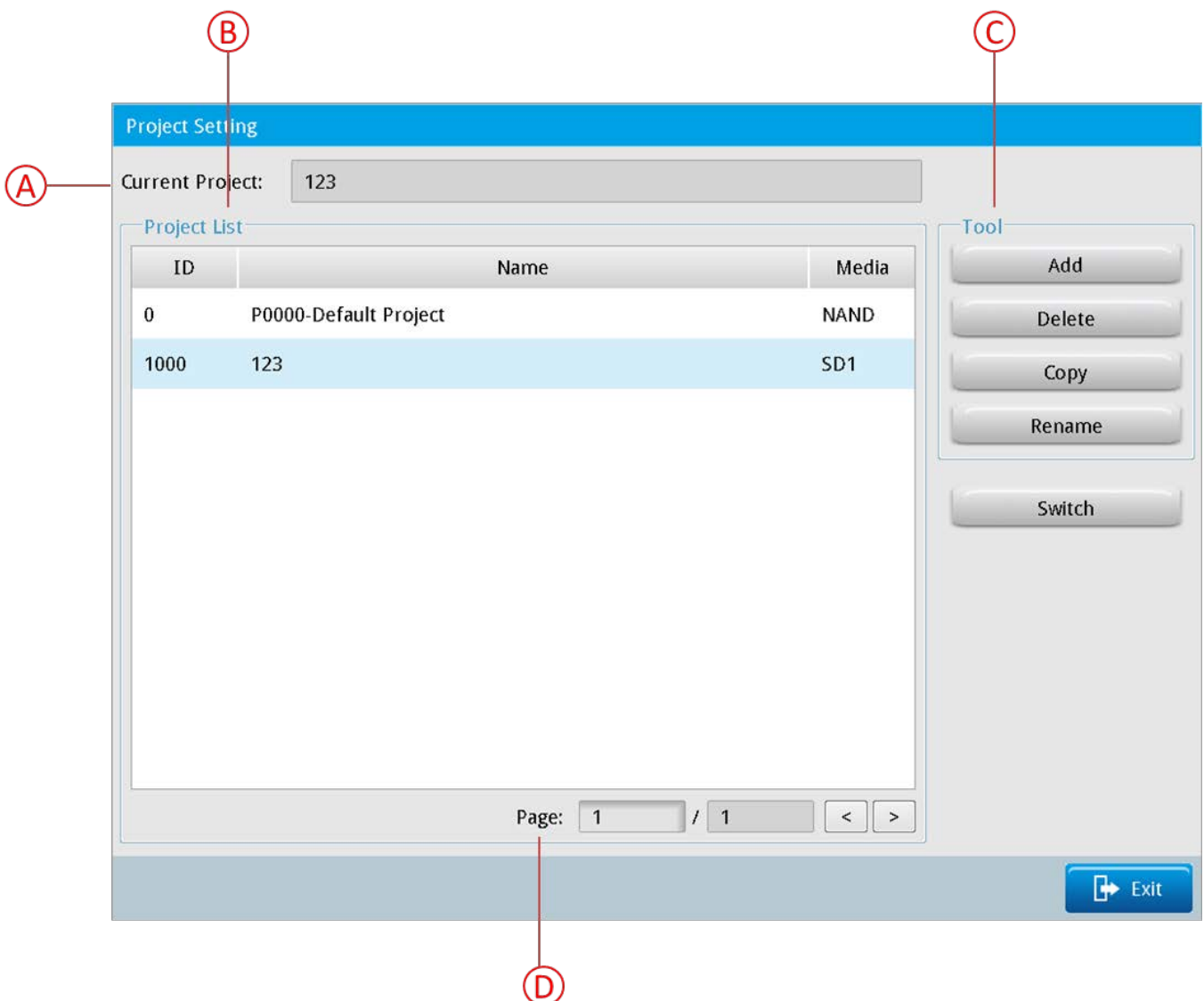

A. Current Project

Displays the name of the current project.

B. Project List

Displays the names of the existing projects stored in the DMV2000 internal memory (up to 1000 projects) and the MicroSD card (up to 9999 projects if the card is installed).

- 1) **ID:** Project number: projects are numbered in the internal memory of the controller from 0–999. Projects numbers in the MicroSD card start at 1000.
- 2) **Name:** name of each project:
- 3) **Media:** location of the stored project: **NAND** is the controller internal memory; **SD** is the memory card.

C. Tool

- 1) **Add:** adds a new project

Parallel Flow: depending on the model, the DMV2000 can simultaneously operate two, four, or eight cameras. Therefore, the system can execute up to eight parallel processes in one project. Select the **Parallel Flow** check box when adding new projects that simultaneously use multiple cameras. You cannot change this setting after you add the new project. Each parallel process can simultaneously trigger inspections without conflicts.

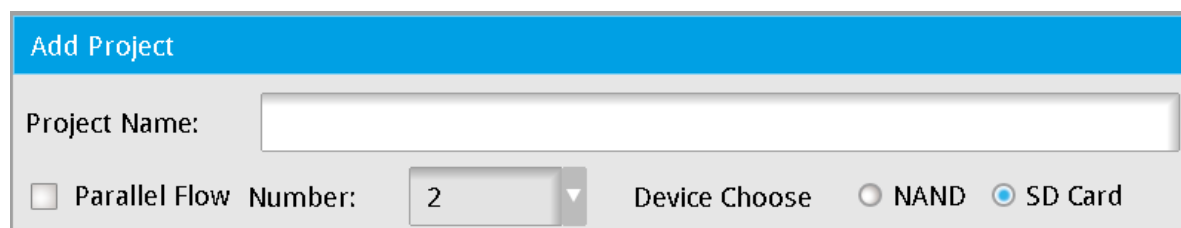

- 2) **Delete:** deletes the selected project
- 3) **Copy:** copies the selected project
- 4) **Rename:** renames the selected project
- 5) **Switch:** switch to the selected project

D. Page

Displays the current page number. Click [**<**] or [**>**] to display the previous or next page in the project list.

3.3 Tool Setting

The **Tool** menu in the DMV2000 Main page displays the settings for the overall internal functions and the relevant parameters for the DMV2000 controller. These include the image register, inspection screen editing during project execution, and Judge settings.

3.3.1 Register Image Management

The Image Register manages the images for the entire controller system and can store, rename, delete, and copy the images captured by the camera. You can manage the images from one or all cameras at the same time. There are two ways to get to the **Register Image Management** dialog box.

- In the Main window, on the **Tool** menu, click **Register Image Management**. To register (store) an image, select the **Live Update** check box to confirm that the camera captures the desired image after you adjust the camera settings and then click **<<Register Image** to complete the process.
- When editing a process flow, click the camera, and then click **Register Image** and then click **<<Register Image** to complete the process.

⊙ **Display and Capture Setting**

➤ **Image Source**

The capture source for image register; always capture from a camera.

➤ **Camera**

Different models of the DMV2000 can connect to two, four, or eight cameras. You set the number of the connected camera in the **Camera** list. When you select a camera, only the captured and registered images from the selected camera appear in the **Image List**.

⊙ **Image List**

The Image List displays the registered images from the selected camera. Image ID numbers are between 1000–8000.

- **All:** Select this check box to include the images from all cameras connected to the controller in the Image List.
- **Rename:** renames the selected image.
- **Delete:** deletes the selected image.
- **Copy:** copies the selected image. After you click Copy enter the **Destination Image Name** and the **Number** of copies you want to make.

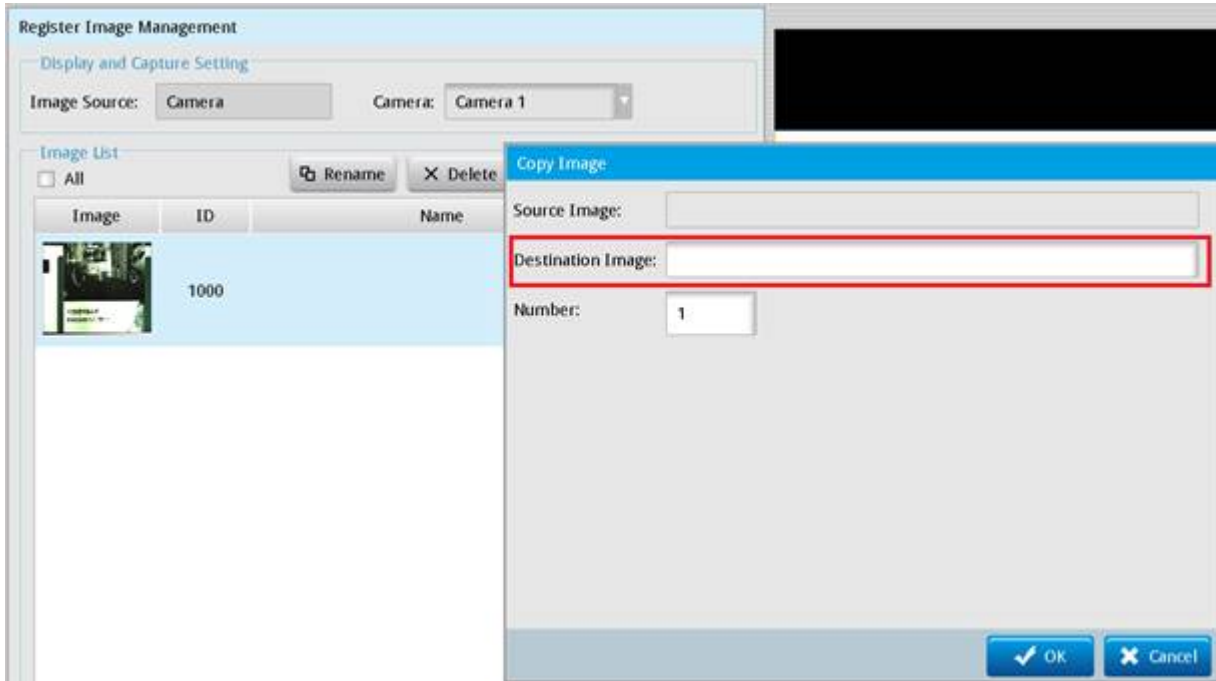

- 1) If making more than two copies, "-1" or "-2" is appended to the name of the copies. For example, if the original image is "ABC" and the Destination Image Name is "XXX" and the number of copies is set to 3, the 3 copied images are named "XXX-1", "XXX-2", and "XXX-3".
 - 2) If making only one copy, "-1" is not added. If the original image name is "ABC", the copied image name is "XXX", and the number of copies is 1, the copied image is named "XXX".
- << **Register**: registers (stores) the current image in the Image Register and allows you to enter a name for the image.

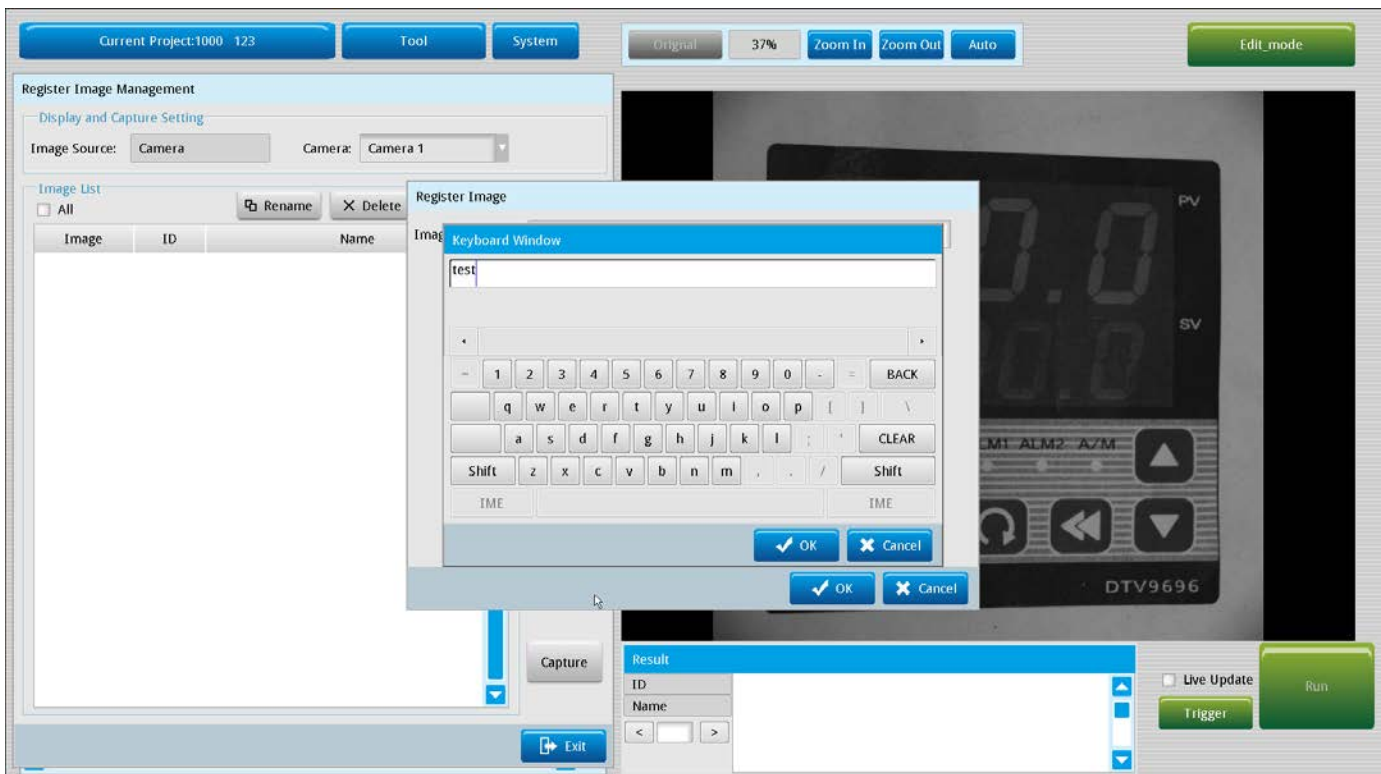

- After you click **OK**, the Image List includes the registered image.



- **Exit**: exits the Register Image Management dialog box and returns to the Main window.

3.3.2 Screen Editing

After you complete setting up the project, you can then run the project. You define the inspection windows that appear during Run mode in **Screen Editing**. In the Main window, on the **Tools** menu, click **Screen Editing**.

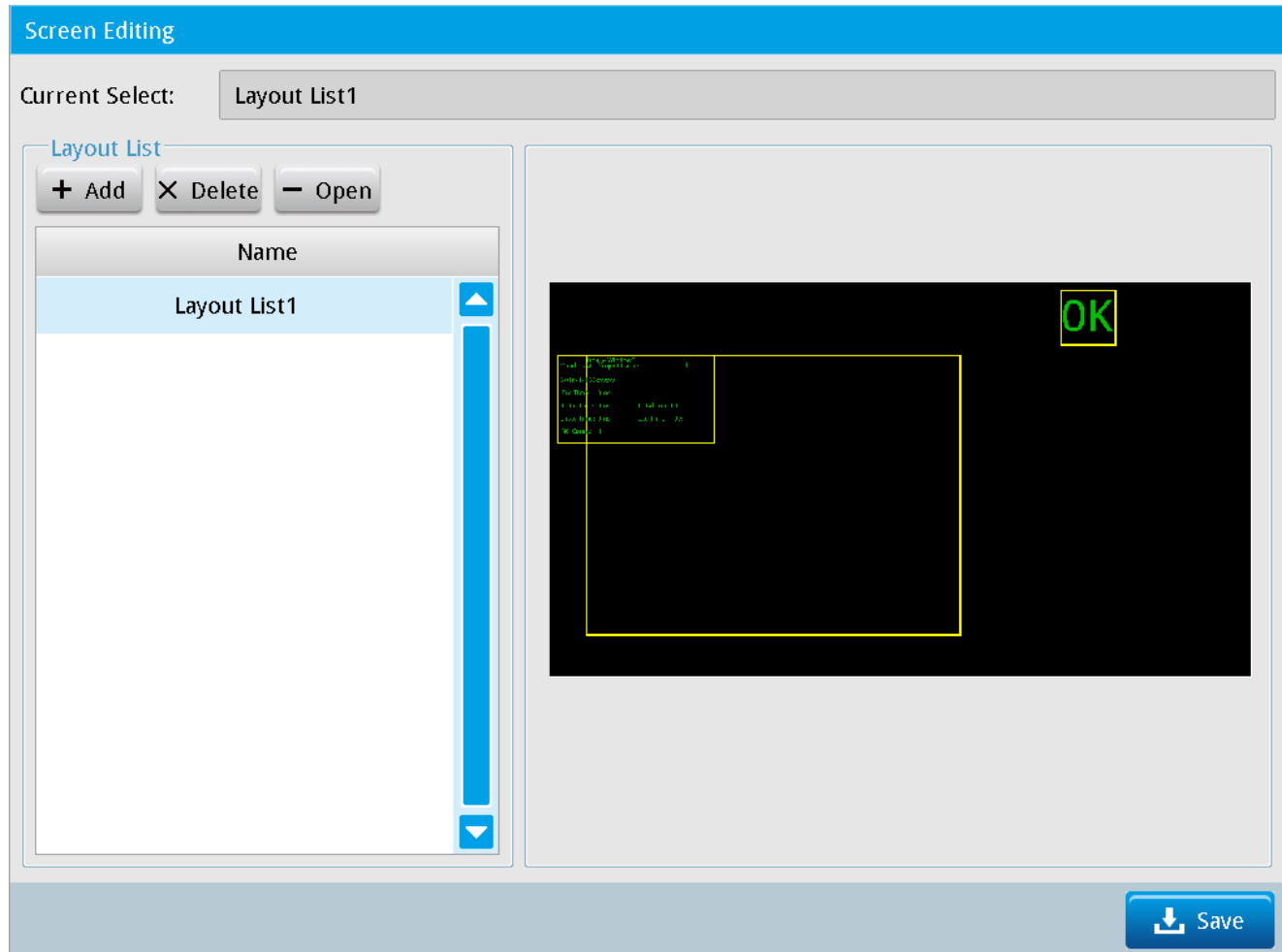

◎ **Layout List**

- **Add:** adds a new window layout to the list and selects the layout method.

You can select 1–4 inspection windows depending on the inspection requirements in a single flow process. You can switch and display the results from multiple inspections in each window.

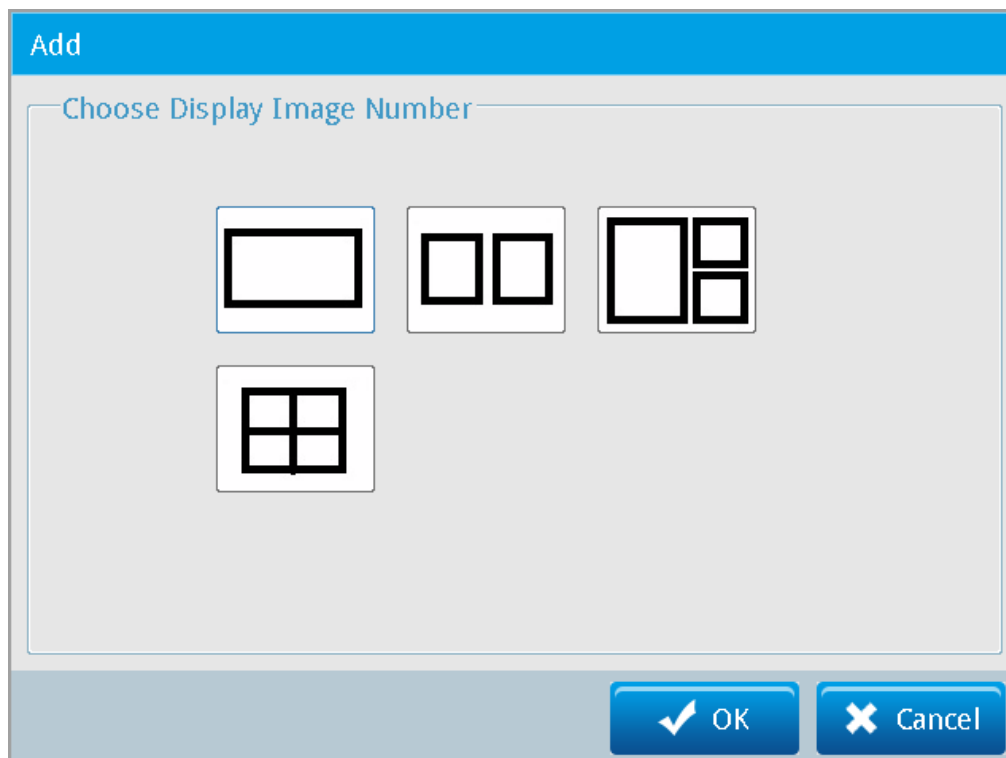

- **Delete:** deletes the selected layout list.
- **Open:** opens the selected layout list in the selected layout method.
- **Save:** saves the Screen Editing settings and returns to the Main window.

◎ Screen Editing Setting

The editing screen is shown in the following picture. Right-click the screen and then click a command.

- **Edit:** adjusts the length, width, and font color of the image window (A).
- **Dot ON/Dot OFF:** turns the dot grid on or off.
- **Close:** leaves the editing screen.

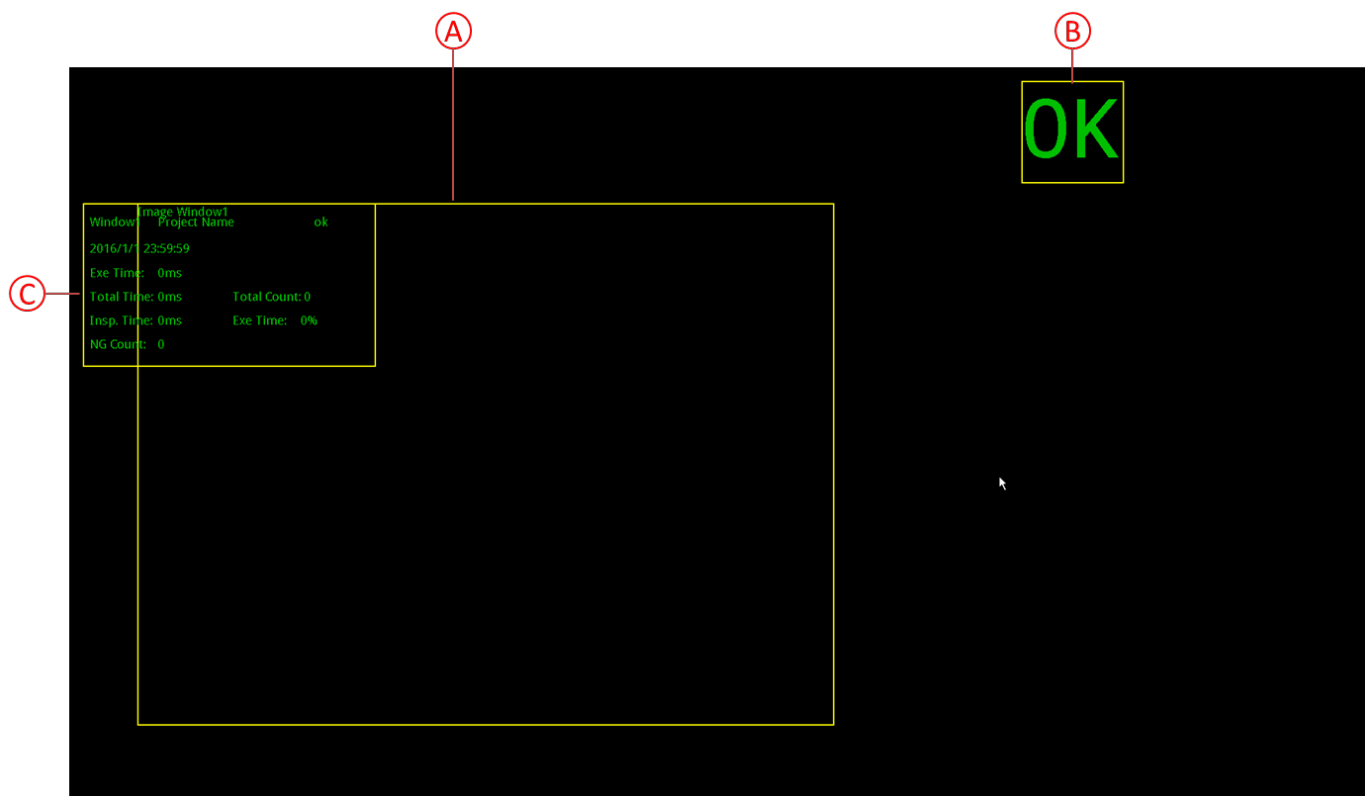

A. Image Window

The window defines when inspections are triggered.

B. Execution Result

Displays **OK** or **NG** when project execution is triggered depending on the inspection results.

C. Data Window

Displays data from the project inspection and includes Project Name, Date and Time, Exe Time, Total Time, Insp. Time, NG Count, Total Count, and NG Rate.

The dot grid is shown in the following picture. The grid aligns the borders of the Image Window and the Data Window.

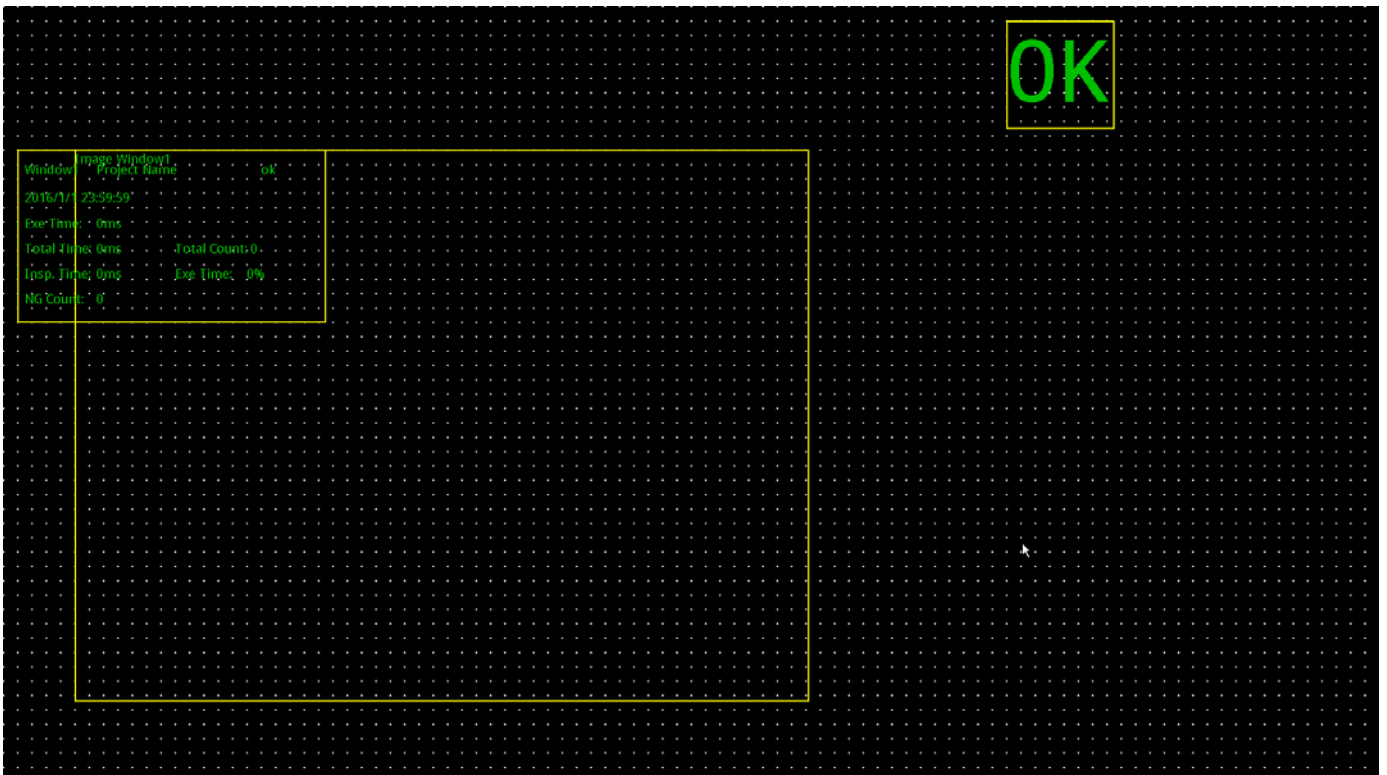

3.3.3 Judge Setting

During project execution, the inspection results **OK** or **NG** appear in the window. The judgment result is based on the reference data you set in **Judge Setting**. In the Main window on the **Tools** menu, click **Judge Setting**.

The steps for the Judge Setting process are: **OKNG** > **Judge Setting** > **Final OK/NG Setting**.

The screenshot shows a software dialog box titled "Setup". It is organized into three main sections:

- Final OK/NG Setting:** A section containing a label "Final-OKNG" and a dropdown menu currently displaying "NONE".
- Judge Setting:** A section containing four buttons arranged in a 2x2 grid, labeled "Tout1", "Tout2", "Tout3", and "Tout4".
- OKNG:** A section containing four rows, each with a label on the left and a "Setup" button on the right. The labels are "FLOW1-OKNG", "FLOW2-OKNG", "FLOW3-OKNG", and "FLOW4-OKNG".

At the bottom right of the dialog, there are two buttons: "OK" (with a checkmark icon) and "Cancel" (with an 'X' icon).

◎ Final OK/NG Setting

Sets the basis for judging whether the final result is OK or NG using one inspection or combining multiple inspections.

- **TOUT1:** If the TOUT1 inspection is OK, the final judge result is OK.
- **TOUT2:** If the TOUT2 inspection is OK, the final judge result is OK.
- **TOUT1 AND TOUT2:** Both the inspection results of TOUT1 and TOUT2 must be OK so that the final judge result is OK.
- **TOUT1 OR TOUT2:** Either the inspection result of TOUT1 or TOUT2 must be OK so that the final judge result is OK.

◎ Judge Setting

Judges whether the TOUT1 and TOUT2 inspection results are OK or NG.

- Add New Process Judgment

Click a **Flown-OKNG** button in the OKNG area and then click **Add** in the **Judge Setting** dialog box. The number of flow processes and items that you have configured for the project appear. You can select the desired flow process or item to include for inspection and judgment.

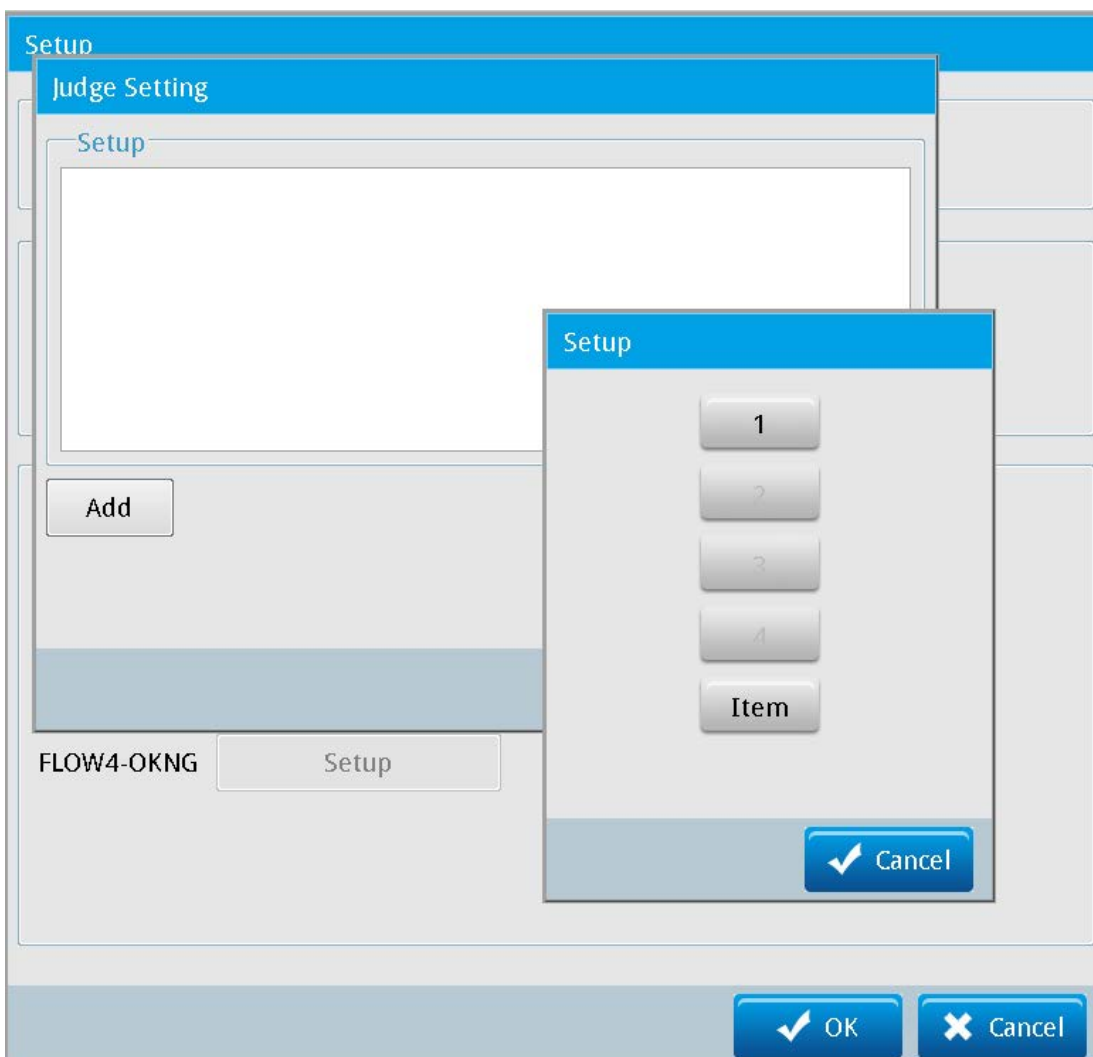

Chapter 3 Basic Operation

- Add New Item Judgment.
- ◆ Choose Type: there are 2 options: **Item** and **Window**.
- ◆ Inspections: list of inspections
- ◆ Parameters: inspections must include Coordinate Positions, Areas, and Perimeter parameters to be displayed here, and also include the Blob, Stain, Edge Position, Shape, Position Trace, or Width Trace.
- ◆ Reference: inspections include Blob, Stain, Edge Position, Shape, Position Trace, and Width Trace.

After adding a new Status Item, you confirm the inspections to be included in the OK/NG judgment in the **Result Output** dialog box.

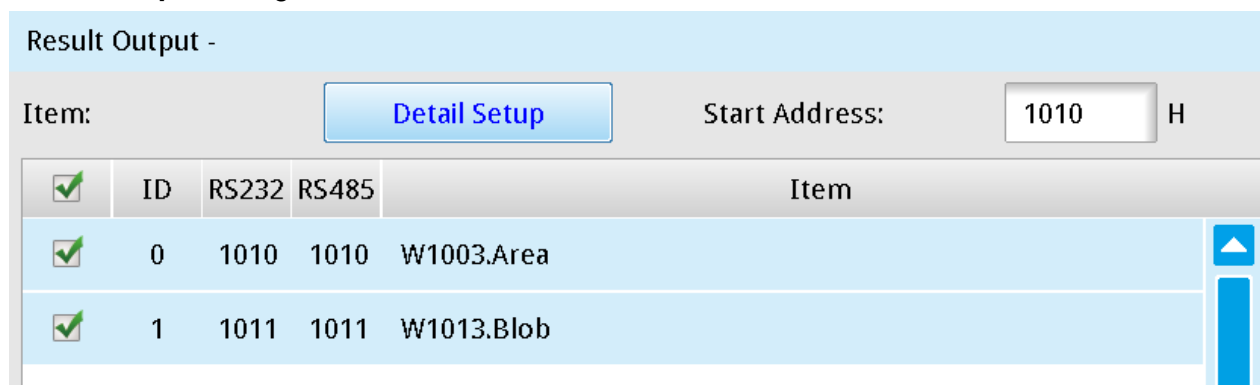

The screenshot shows the 'Result Output' dialog box. At the top, there is a header 'Result Output -'. Below this, there are two fields: 'Item:' with a 'Detail Setup' button next to it, and 'Start Address:' with a text box containing '1010' and a unit 'H'. Below these fields is a table with the following data:

<input checked="" type="checkbox"/>	ID	RS232	RS485	Item
<input checked="" type="checkbox"/>	0	1010	1010	W1003.Area
<input checked="" type="checkbox"/>	1	1011	1011	W1013.Blob

◎ **OKNG**

- ◆ Choose Type: there are 2 options: **Item** and **Window**.
- ◆ Element: list of inspections
- ◆ Parameters: inspections must include Coordinate Positions, Areas, and Perimeter parameters to be displayed here, and also include Blob, Stain, Edge Position, Shape, Position Trace, or Width Trace.
- ◆ Reference: inspections include Blob, Stain, Edge Position, Shape, Position Trace, or Width Trace.

After adding a new Status Item, you can select the inspections to be included in the OK/NG judgment the **Status Item** dialog box.

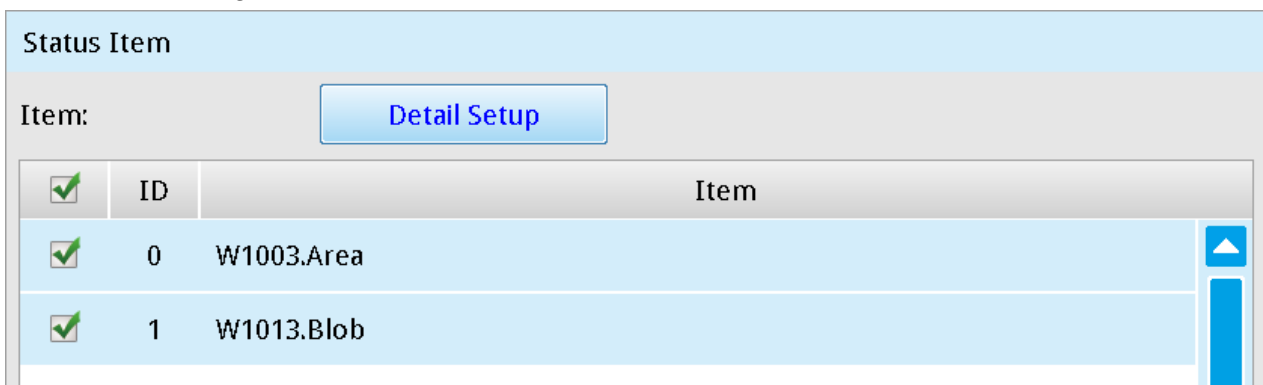

 **Reference** Please refer to Section 6 for detailed information on using Judge Settings.

3.4 System Setting

This chapter explains the System settings. In Edit mode, the Main window shows the three setting buttons: **Current Project**, **Tool**, and **System**. On the Main window, click **System** to view and edit the internal controller settings in the **Controller Setting** dialog box. Note that the system settings are applied to all inspection projects, and do not change for different projects.

3.4.1 General Setting

⊙ **Device**

Delta DMV2000

⊙ **Date & Time**

Enter the current date and time.

⊙ **Language Setting**

Selects the language; either Traditional Chinese or English.

 **Remark** You must restart the system after changing the language setting.

⊙ **Startup Screen**

Selects the mode when the controller starts: **Run Mode** or **Setup Mode** (Edit mode).

➤ **Setup Mode**

The initial screen of the controller displays the project settings and you can change the project settings as well as add, rename, and delete projects. This is also called Edit mode.

➤ **Run mode**

The initial screen of the controller displays the running project. This option requires that you create one or more projects, so that the inspection project immediately begins after the controller activates.

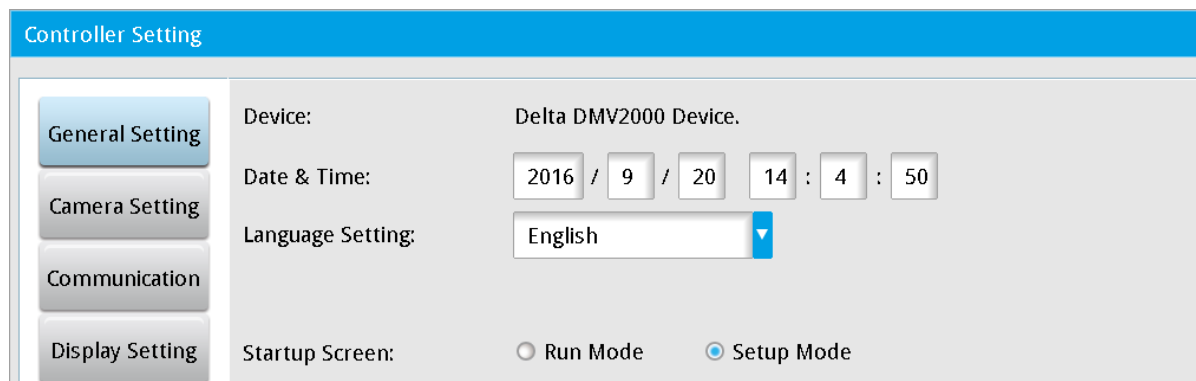

Controller Setting

General Setting

Camera Setting

Communication

Display Setting

Device: Delta DMV2000 Device.

Date & Time: 2016 / 9 / 20 14 : 4 : 50

Language Setting: English

Startup Screen: Run Mode Setup Mode

3.4.2 Camera Setting

I. Individual Setting

Use this page to set up all relevant parameters for the controller's cameras, including the three options for **Camera Setting**, **White Balance**, and **ROI**.

◎ Camera Setting

Depending on the model, the DMV2000 can simultaneously operate two, four, or eight cameras. You can select **Camera 1–Camera 8** as the working camera. Each camera can be set as color or gray-scale. After connecting to the camera, the controller prompts whether to automatically detect and upload the camera model and specifications; otherwise you must manually configure the camera.

Individual Setting

Camera Setting

White Balance

ROI

Select Working Camera

Camera 1
▼

Camera Model:	Delta Camera DCC-500
Camera Mode:	24bit Color
Resolution :	4.00 Megapixels
Frame Rate :	FPS 39
Shutter Speed :	<div style="display: flex; align-items: center;"> <div style="border: 1px solid #ccc; padding: 2px; flex-grow: 1;">16.67ms</div> <div style="color: #add8e6; font-size: 0.8em; margin: 0 5px;">▼</div> <div style="border: 1px solid #ccc; padding: 2px; width: 80px; text-align: center;">16667</div> <div style="margin-left: 5px;">us</div> </div>
Gain:	<div style="display: flex; align-items: center;"> <div style="flex-grow: 1;"> <input style="width: 100%; height: 15px;" type="range"/> </div> <div style="border: 1px solid #ccc; padding: 2px; width: 60px; text-align: center;">0</div> </div>
Luminance:	<div style="display: flex; align-items: center;"> <div style="flex-grow: 1;"> <input style="width: 100%; height: 15px;" type="range"/> </div> <div style="border: 1px solid #ccc; padding: 2px; width: 60px; text-align: center;">0</div> </div>
Clamp:	<div style="display: flex; align-items: center;"> <div style="flex-grow: 1;"> <input style="width: 100%; height: 15px;" type="range"/> </div> <div style="border: 1px solid #ccc; padding: 2px; width: 60px; text-align: center;">40</div> </div>
Distance per Pixels:	1.000
HDR Enable:	<input type="checkbox"/> Enable
HDR parameter1:	<div style="display: flex; align-items: center;"> <div style="flex-grow: 1;"> <input style="width: 100%; height: 15px;" type="range"/> </div> <div style="border: 1px solid #ccc; padding: 2px; width: 60px; text-align: center;">1</div> </div>

➤ **Camera Model**

The controller reads this from the camera.

➤ **Camera Mode**

The controller reads this from the camera.

➤ **Resolution**

The controller reads this from the camera.

➤ **Frame Rate**

The controller reads this from the camera.

➤ **Shutter Speed**

Select the shutter setting (the default is user-defined) from a list. A longer shutter time increases the exposure and the amount of light absorbed, and is useful when there is insufficient lighting.

➤ **Gain**

Range: 0–255; a higher gain results in a brighter image but the image may contain more noise.

➤ **Luminance**

Range: 0–10; a higher luminance results in a brighter image but the actual luminosity variation is less than the gain adjustment.

➤ **Clamp**

Range: 0–255; a higher clamp value results in a brighter image but actual luminosity variation is less than luminance adjustment.

➤ **Distance/Pixel**

The ratio between the on-screen pixels and actual distance; the units of pixels are converted to actual units.

➤ **HDR**

Range: 0–254; high dynamic range is only suitable for gray-scale cameras; a low parameter value results in a low exposure and can only develop whitish and overexposed outlines; regions of denser black pixels on the original image become darker.

◎ White Balance Setting

Restores the colors of the selected image and calibrates the colors. Drag the white balance region to the position on the screen that should be white, and then select **Auto Setting**. The following picture is before applying white balance.

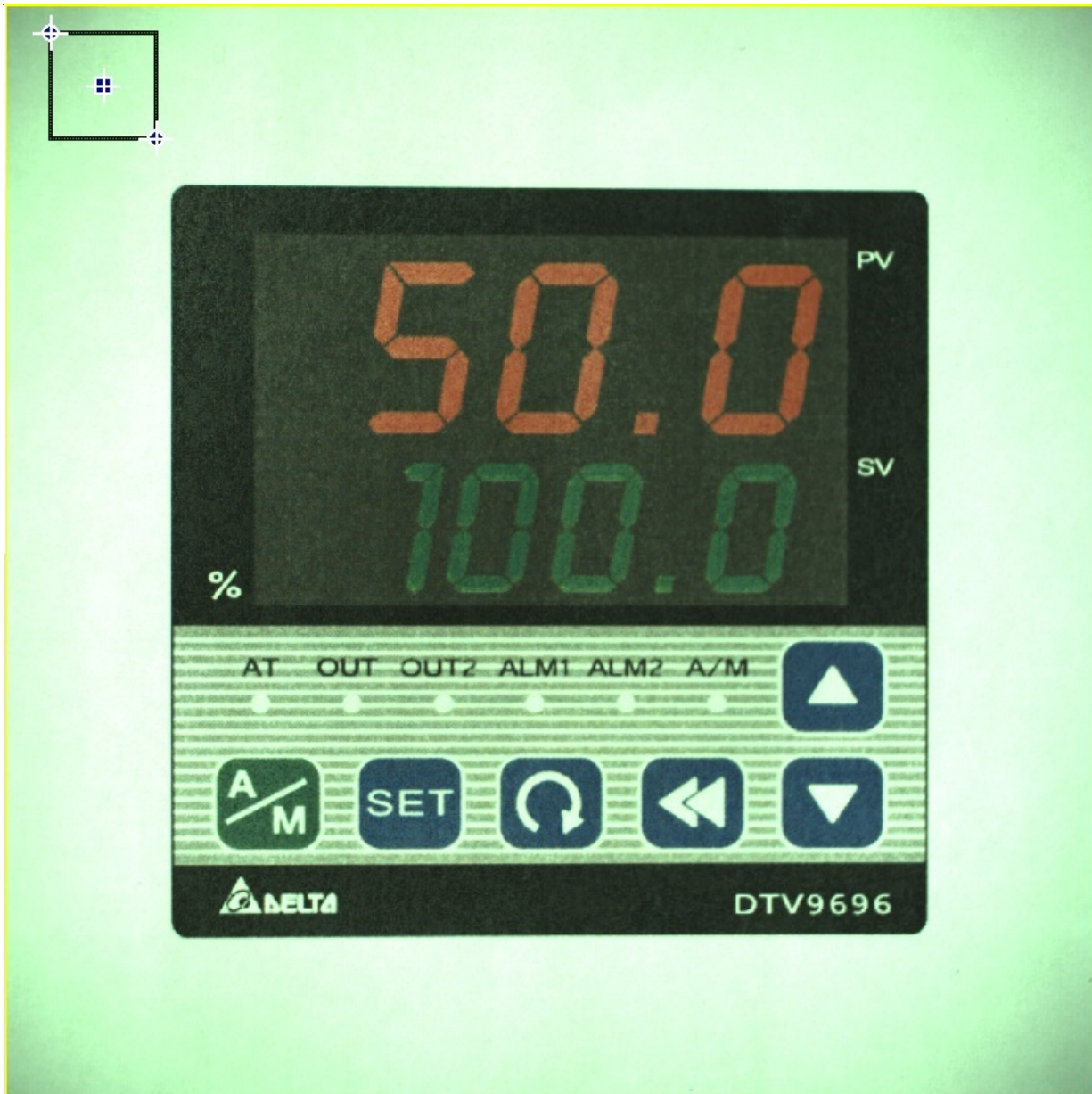

- The following picture is after applying white balance calibration.



- **Inspection Region**

Displays the X and Y coordinates (X0, Y0) and (X1, Y1) of the white balance region; the image shows the deviation from the color tone corrected based on the white reference of the region.

Remark Click **Reset** to reposition and resize the selected region for white balance.

- **Average RGB in Region**

Calculates the RGB values for the pixels in the selected region for white balance.

► White Balance Coefficient

Range: 0–1; a larger value results in a higher color density. When the three values obtained by multiplying the white balance coefficient with the RGB average within the region are similar; the color in the inspected region is close to white.

Remark Click **Auto Setting** and the system automatically adjusts the white balance coefficient according to the selected region.

◎ ROI

Defines the region of interest when capturing images. This saves image processing time during inspections and measurements; you can adjust the size of the inspection region according to the application. See Section 4.3 for more information on defining the ROI.

II. Common Setting

Common setting primarily sets the conditions of the trigger for the inspection process and relevant parameters of the flash light, included in the options for **Trigger Setup** and **Flash Setting**. In the Main window, click **System**, then click **Camera Setting**, and then click **Common Setting**.

◎ Trigger Setup

There are five ways to set up the trigger for the inspection processes: external terminal, internal trigger, Ethernet, RS-232, and RS485. A single inspection process can be triggered by up to four types of triggers.

Trigger Type:	Trigger1(Terminal)
Trigger Type:	Terminal
Interval (ms):	Internal Trigger
Trigger Delay (ms)	Terminal
Configuration:	Ethernet(TCP/IP)
	RS-232
	RS-485

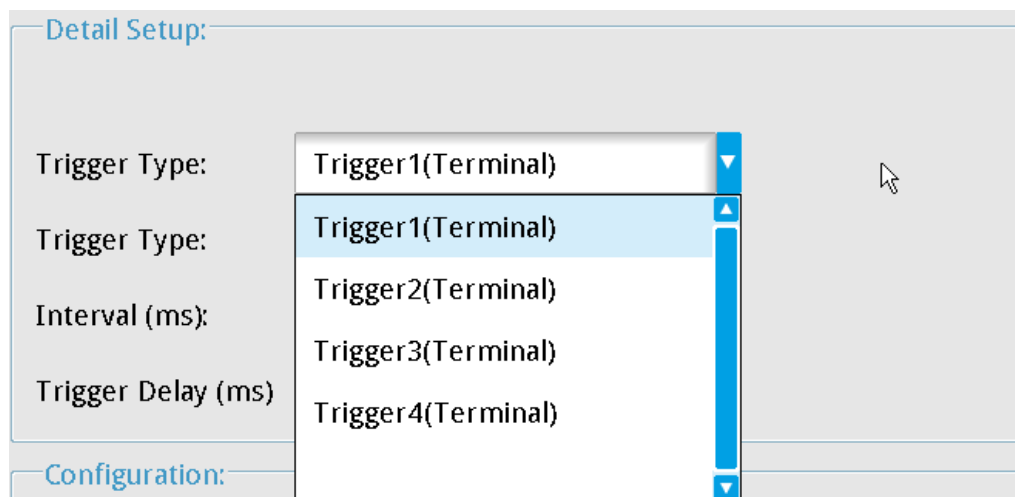

► External Trigger

Trigger by external device through varying interfaces; a single inspection process can be triggered by up to four types of triggers.

- 1) **External Terminal:** Input trigger signal using I/O to execute process inspection.
- 2) **RS232:** Input communication command through the serial interface to execute process inspection.
- 3) **RS485:** Input communication command through the serial interface to execute process inspection.
- 4) **Ethernet:** Input communication command through the Ethernet interface to execute process inspection.

► Internal Trigger

Can only be set up on Trigger 1; automatically triggers according to the set time; suitable for applications requiring timed inspections; includes both **Interval (ms)** and **Trigger Delay (ms)** settings for timed inspections.

The following picture shows the Trigger Setup for the internal trigger.

Common Setting

Trigger Setup

Flash Setting

Detail Setup:

Trigger Type: Trigger1(Terminal)

Trigger Type: Terminal

Interval (ms): 1000

Trigger Delay (ms) 100

Configuration:

Flow Chart	1	2	3	4	5	6	7	8
Trigger1	<input checked="" type="checkbox"/>	<input checked="" type="checkbox"/>	<input type="checkbox"/>	<input type="checkbox"/>	<input type="checkbox"/>	<input type="checkbox"/>	<input type="checkbox"/>	<input type="checkbox"/>
Trigger2	<input checked="" type="checkbox"/>	<input type="checkbox"/>	<input type="checkbox"/>	<input type="checkbox"/>	<input type="checkbox"/>	<input type="checkbox"/>	<input type="checkbox"/>	<input type="checkbox"/>
Trigger3	<input type="checkbox"/>	<input type="checkbox"/>	<input type="checkbox"/>	<input type="checkbox"/>	<input type="checkbox"/>	<input type="checkbox"/>	<input type="checkbox"/>	<input type="checkbox"/>
Trigger4	<input type="checkbox"/>	<input type="checkbox"/>	<input type="checkbox"/>	<input type="checkbox"/>	<input type="checkbox"/>	<input type="checkbox"/>	<input type="checkbox"/>	<input type="checkbox"/>
Trigger5	<input type="checkbox"/>	<input type="checkbox"/>	<input type="checkbox"/>	<input type="checkbox"/>	<input type="checkbox"/>	<input type="checkbox"/>	<input type="checkbox"/>	<input type="checkbox"/>
Trigger6	<input type="checkbox"/>	<input type="checkbox"/>	<input type="checkbox"/>	<input type="checkbox"/>	<input type="checkbox"/>	<input type="checkbox"/>	<input type="checkbox"/>	<input type="checkbox"/>
Trigger7	<input type="checkbox"/>	<input type="checkbox"/>	<input type="checkbox"/>	<input type="checkbox"/>	<input type="checkbox"/>	<input type="checkbox"/>	<input type="checkbox"/>	<input type="checkbox"/>
Trigger8	<input type="checkbox"/>	<input type="checkbox"/>	<input type="checkbox"/>	<input type="checkbox"/>	<input type="checkbox"/>	<input type="checkbox"/>	<input type="checkbox"/>	<input type="checkbox"/>

◎ Flash Setup

Flash controls the lighting output in sync with the camera shutter when capturing images. Depending on the model, the DMV2000 can connect to up to 8 cameras. Therefore you can set up to 8 flash configurations. You can set up multiple flash configurations for the same process or for different processes. The following picture shows the Flash Setting options.

Common Setting

Trigger Setup

Flash Setting

Select Flash

Select Flash: Flash1

Enable/Disable: Enable Disable

Flash Action: After action Before action

Output Start Time: 10.0 ms During Time: 20.0 ms

Configuration:

Camera	1	2	3	4	5	6	7	8
Flash1	<input checked="" type="checkbox"/>	<input type="checkbox"/>	<input type="checkbox"/>	<input type="checkbox"/>	<input type="checkbox"/>	<input type="checkbox"/>	<input type="checkbox"/>	<input type="checkbox"/>
Flash2	<input checked="" type="checkbox"/>	<input type="checkbox"/>	<input type="checkbox"/>	<input type="checkbox"/>	<input type="checkbox"/>	<input type="checkbox"/>	<input type="checkbox"/>	<input type="checkbox"/>
Flash3	<input type="checkbox"/>	<input type="checkbox"/>	<input type="checkbox"/>	<input type="checkbox"/>	<input type="checkbox"/>	<input type="checkbox"/>	<input type="checkbox"/>	<input type="checkbox"/>
Flash4	<input type="checkbox"/>	<input type="checkbox"/>	<input type="checkbox"/>	<input type="checkbox"/>	<input type="checkbox"/>	<input type="checkbox"/>	<input type="checkbox"/>	<input type="checkbox"/>
Flash5	<input type="checkbox"/>	<input type="checkbox"/>	<input type="checkbox"/>	<input type="checkbox"/>	<input type="checkbox"/>	<input type="checkbox"/>	<input type="checkbox"/>	<input type="checkbox"/>
Flash6	<input type="checkbox"/>	<input type="checkbox"/>	<input type="checkbox"/>	<input type="checkbox"/>	<input type="checkbox"/>	<input type="checkbox"/>	<input type="checkbox"/>	<input type="checkbox"/>
Flash7	<input type="checkbox"/>	<input type="checkbox"/>	<input type="checkbox"/>	<input type="checkbox"/>	<input type="checkbox"/>	<input type="checkbox"/>	<input type="checkbox"/>	<input type="checkbox"/>
Flash8	<input type="checkbox"/>	<input type="checkbox"/>	<input type="checkbox"/>	<input type="checkbox"/>	<input type="checkbox"/>	<input type="checkbox"/>	<input type="checkbox"/>	<input type="checkbox"/>

➤ Select Flash

Select the flash to configure.

➤ Enable/Disable

Flash can only be turned on when you select **Enable**.

➤ Flash Action

After Action: the flash activates only after the camera shutter engages.

Before Action: the flash activates before the camera shutter engages.

➤ Output Start Time

Sets the delay time between the flash and the shutter; the timing depends on the **Flash Action** settings.

For example: if you set this value is 10 ms:

- ◆ For **After Action**, the shutter first activates to capture the image after the capture trigger signal; then the flash activates after the 10 ms delay.
- ◆ For **Before Action**, the flash first activates after the capture trigger signal; then the shutter activates after the 10 ms delay. This is the generally recommended method.

➤ During Time

Sets the total flash duration. To ensure that the flash can activate and hold for a certain duration when the shutter activates, set During Time to a value greater than the sum of **Output Start Time** and **Shutter Speed**.

3.4.3 Communication Setting

The DMV2000 controller can establish a communication connection with the superior controller (such as a PLC) through the external (I/O) terminals. The settings include **Device Setting** and **Protocol Setting** dialog boxes for each communication method. In the Main window, click **System**, then click **Communication**, and then click **Device Setting** or **Protocol Setting**.

I. Device Setting

⊙ External Terminal

Sets whether to enable receiving signals from external (I/O) terminals and the signal reception methods

INPUT: IN1–IN8

OUTPUT: OUT1–OUT11

➤ Enabling External Terminal

For **Signal Test Mode** select **Disable**, and then select the external terminal to be tested and select **Enable**.

The upper half of the table is for the controller signal input, and the lower half of the table is for the controller signal output.

➤ Test Signal

For **Signal Test Mode**, select **Enable**

When the external (I/O) terminal is connected to the controller and enabled, the test signal is turned on and the indicator to the right of the enabled terminal changes to green.

The upper half of the table is for the controller signal input terminal. When you select the **Enable** check box for an external terminal, the indicator to the right of the enabled terminal changes to green. The lower half of the table is for the controller signal output terminal. When you select the **Enable** check box for an

external terminal, the indicator to the right of the enabled terminal changes to green.

Device Setting

External Terminal

Ethernet

RS232

RS485

Signal Test Mode: Enable Disable Restore Default Setting

Enable	Terminal	Signal Phase Setting	Signal	Test Signal
<input checked="" type="checkbox"/>	IN1	None	TRIG1	Command Input +
<input type="checkbox"/>	IN2	None	TRIG2	Input -
<input type="checkbox"/>	IN3	None	TRIG3	Input -
<input type="checkbox"/>	IN4	None	TRIG4	Input -
<input type="checkbox"/>	IN5	None	TEST	Input -
<input type="checkbox"/>	IN6	None	PLINK	Input -
<input type="checkbox"/>	IN7	None	TROFF	Input -
<input type="checkbox"/>	IN8	None	ACK	Input -

Enable	Terminal	Signal Phase Setting	Signal	Test Signal
<input checked="" type="checkbox"/>	OUT1	Normal Output	RDY	Command Output +
<input type="checkbox"/>	OUT2	Normal Output	TOUT1	Output -
<input type="checkbox"/>	OUT3	Normal Output	TOUT2	Output -

✓ OK

✗ Cancel

Remark Click **Restore Default Setting** to return to initial settings.

➤ Signal Phase Setting

You can configure this only for the output. The signal is output to the external terminal through Contact A in normal output to receive the controller transmitted signals. The signal is output to the external controller through Contact B in inverse output to receive the external terminal transmitted signals.

➤ **Signal**

These include 64 options: RDY, TOUT1, TOUT2, ERR, STR, REND1, REND2, REND3, REND4, FLH1, FLH2, SW, NSW, FRDY, DO1, DO2, DO3, DO4, DO5, OUT1, OUT2, OUT3, OUT4, OUT5, OUT6, OUT7, OUT8, OUT9, OUT10, OUT11, OUT12, OUT13, OUT14, OUT15, OUT16, REND5, REND6, REND7, REND8, DO6, DO7, DO8, DO9, FLH3, FLH4, FLH5, FLH6, FLH7, FLH8, NA, RDY2, RDY3, RDY4, RDY5, RDY6, RDY7, RDY8, ERR2, ERR3, ERR4, ERR5, ERR6, ERR7, and ERR8

Remark In output configuration signals TOUT1, TOUT2, and STR, you can click the small square box to the right of the Signal column to display the **Protocol Setting** dialog box.

The screenshot shows the 'Device Setting' dialog box. On the left, there are buttons for 'External Terminal', 'Ethernet', 'RS232', and 'RS485'. The main area is titled 'Signal Test Mode: Enable Disable' with a 'Restore Default Setting' button. Below this are two tables for configuring signals.

Enable	Terminal	Signal Phase Setting	Signal	Test Signal
<input type="checkbox"/>	IN1	None	TRIG1	Disable
<input type="checkbox"/>	IN2	None	TRIG2	Disable
<input type="checkbox"/>	IN3	None	TRIG3	Disable
<input type="checkbox"/>	IN4	None	TRIG4	Disable
<input type="checkbox"/>	IN5	None	TEST	Disable
<input type="checkbox"/>	IN6	None	PLINK	Disable
<input type="checkbox"/>	IN7	None	TROFF	Disable
<input type="checkbox"/>	IN8	None	ACK	Disable

Enable	Terminal	Signal Phase Setting	Signal	Test Signal
<input type="checkbox"/>	OUT1	Normal Output	RDY	Disable
<input type="checkbox"/>	OUT2	Normal Output	TOUT1	Disable
<input type="checkbox"/>	OUT3	Normal Output	TOUT2	Disable

At the bottom right, there are 'OK' and 'Cancel' buttons.

Reference Please refer to Chapter 7 for detailed communication settings for I/O signals.

Ⓒ Ethernet

Sets the IP and other information for the controller when using Ethernet.

Device Setting

External Terminal	IP Version:	<input checked="" type="radio"/> IPv4
Ethernet	IP Address:	<input type="text" value="192"/> . <input type="text" value="168"/> . <input type="text" value="1"/> . <input type="text" value="2"/>
RS232	Subnet Mask:	<input type="text" value="255"/> . <input type="text" value="255"/> . <input type="text" value="255"/> . <input type="text" value="0"/>
RS485	Default Gateway:	<input type="text" value="192"/> . <input type="text" value="168"/> . <input type="text" value="1"/> . <input type="text" value="1"/>
	Port:	<input type="text" value="502"/>
	MAC Address:	D0 : 39 : 72 : 07 : 6D : 94

OK Cancel

◎ RS232

The RS232 communication format default (and other available) values are:

Baud Rate: 115200 (2400, 4800, 9600, 19200, 38400, 57600, 115200)

Stop Bit: 1 (1, 2)

Parity Bit: None (odd, even, none)

Data Bit: 8-bit (7, 8)

The screenshot shows a software interface titled "Device Setting". On the left side, there is a vertical stack of four buttons: "External Terminal", "Ethernet", "RS232", and "RS485". The "RS232" button is highlighted in blue. The main area of the dialog is light gray and contains the following settings:

- Baud Rate:** A dropdown menu showing "115200".
- Stop Bit:** Two radio buttons, "1" (selected) and "2".
- Parity Bit:** Three radio buttons, "None" (selected), "Odd", and "Even".
- Data Bit:** Two radio buttons, "7-bit" and "8-bit" (selected).

At the bottom right of the dialog, there are two buttons: "OK" (with a checkmark icon) and "Cancel" (with an 'X' icon).

◎ RS485

The RS485 communication format default (and other available) values are as follows:

Baud Rate: 115200 (2400, 4800, 9600, 19200, 38400, 57600, 115200)

Stop bit: 1 (1, 2)

Parity Bit: None (odd, even, none)

Data Bit: 8-bit (7, 8)

ID: 1

The screenshot shows a 'Device Setting' dialog box with a blue header. On the left, there is a vertical list of communication protocols: 'External Terminal', 'Ethernet', 'RS232', and 'RS485'. The 'RS485' option is selected and highlighted in blue. The main area of the dialog contains the following settings:

- Baud Rate:** A dropdown menu showing '115200'.
- Stop Bit:** Radio buttons for '1' (selected) and '2'.
- Parity Bit:** Radio buttons for 'None' (selected), 'Odd', and 'Even'.
- Data Bit:** Radio buttons for '7-bit' and '8-bit' (selected).
- ID:** A text input field containing the number '1'.

At the bottom right of the dialog, there are two buttons: 'OK' (with a checkmark icon) and 'Cancel' (with an 'X' icon).

II. Protocol Setting

⊙ External Terminal Settings

Sets up the output reception data.

Configure the General, SW and NSW, OUTPUT, STR, and TOUT settings in order.

Protocol Setting

External Terminal

Ethernet

RS232

RS485

General

Data Output Delay Time: 0.0 ms

SW and NSW

SW and NSW: 0.0 ms

OUTPUT

Output Num. Pins: 8 Pins 16 Pins

Data Format: 32 Bits

STR

Handshake: Enable Disable

STR Delay Time: 10.0 ms

STR Output Time: 20.0 ms

Data Output Time: 40.0 ms

TOUT

OK Cancel

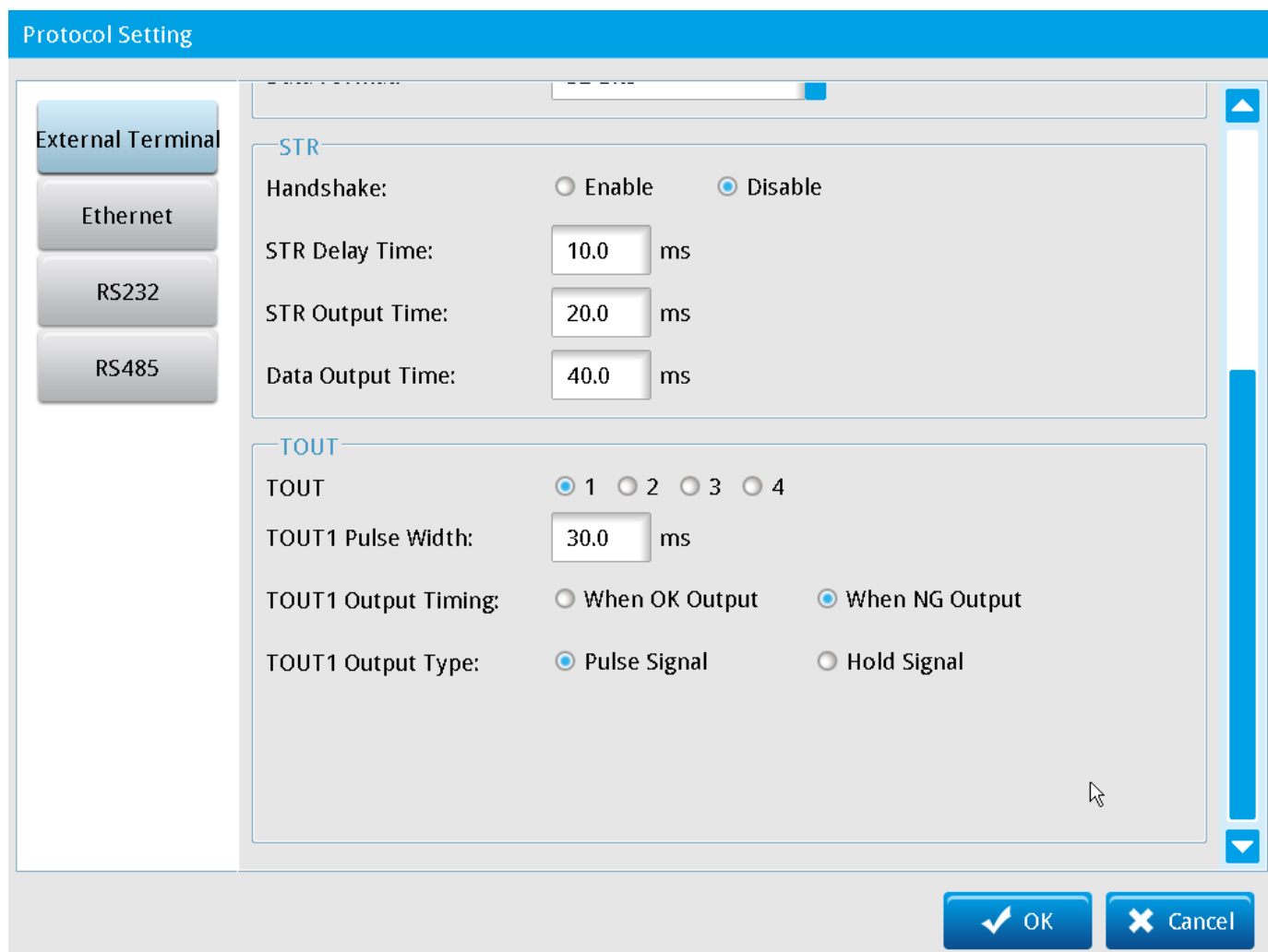

Reference

Please refer to Chapter 7 for detailed communication settings for external terminal signals.

◎ **Ethernet**

Configures the Ethernet command execution data during communication.

Protocol Setting

External Terminal

Ethernet

RS232

RS485

Port: 2048

IP Address: 192 . 168 . 1 . 3

OK Cancel

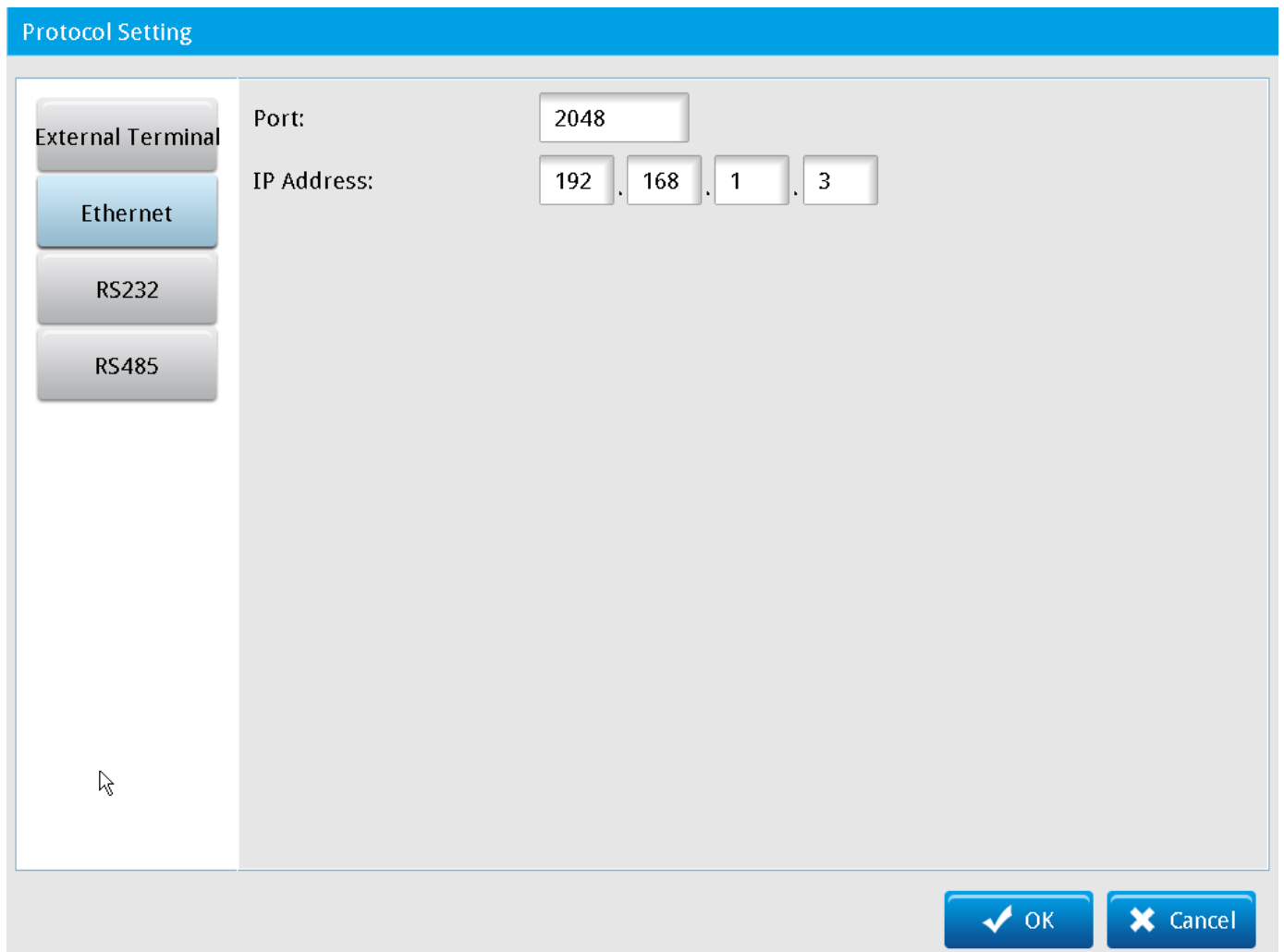

 **Reference** Refer to Section 8.6 for detailed communication settings for Ethernet signals.

◎ RS232

Configures the RS232 command execution data during communication

- **Data Format:** select **16 bits** or **32 bits**.
- **Protocol:** select configure **Private Code** or **PLC link**.

◆ Private Code

Click **Detail Setup** and enter the user-defined private code.

Private Code Format: select **Default** or **user defined private codes**.

The following picture shows the setting for the Custom Private Code for RS232.

Custom private code

Setup

Private Code Format: Default

Data Return To T1~T4 Byte Output (4-Bytes Float Type)

Show plus sign for positive numbers Single Zero

Data Format Fixed Window is NG, don't output

9 Digit Number (Including plus-minus sign and decimal point)

Output data zero filling

Output value is decimal, whether the decimal point output?

Digit Place: 2

Data Type: Output Integer (Data x 100)

Data Test: 0.000000

Test Result:

Start Symbol Start Symbol Length: 2

Byte0 54 30 00 00 00 00 00 00 00 00 00 00 00 00 00

Byte8

Byte15

T 0

Gap Symbol Gap Symbol Length: 1

Byte0

OK Cancel

Reference

Please refer to Section 8.2 for the detailed setup for the private code for RS232.

◆ PLC Link

Through PLC link, the DMV2000 can establish communication directly with the PLC. The current version of the DMV2000 supports only the Delta PLC connection. Configure the **Start Address**, **Complete Flag**, **Timeout**, and **ID** to complete the connection setting.

The screenshot shows the 'Protocol Setting' dialog box. On the left, there is a vertical list of connection options: 'External Terminal', 'Ethernet', 'RS232', and 'RS485'. The 'RS232' option is highlighted in blue. The main area of the dialog is for configuring the 'PLC Link' protocol. It includes the following settings:

- Data Format:** 16 Bits (dropdown menu)
- Protocol:** Private Code, PLC Link
- Detail Setup:**
 - PLC Manufacturer:** Delta Electronics (dropdown menu)
 - PLC Type:** NONE (dropdown menu)
 - Start Address:** 1000 H (text input)
 - Complete Flag:** 1100 H (text input)
 - Timeout:** 10.0 ms (text input)
 - ID:** 1 (text input)

At the bottom right, there are 'OK' and 'Cancel' buttons.

 **Reference** Please refer to Section 8.3 for the detailed setup for the PLC link for RS232.

◎ RS485

Configures the RS485 command execution data during communication

➤ Data Format

Setting Contents: select **16 bits** or **32 bits**.

➤ Protocol: select configure **Private Code** or **PLC link**.

◆ Private Code

Click **Detail Setup** and enter the user defined private code.

Private Code Format: select **Default** or **user defined private codes**.

The following picture shows the setting for the Custom Private Code for RS485.

Custom private code

Setup

Private Code Format: **Default**

Data Return To T1~T4 Byte Output (4-Bytes Float Type)

Show plus sign for positive numbers Single Zero

Data Format Fixed Window is NG, don't output

9 Digit Number (Including plus-minus sign and decimal point)

Output data zero filling

Output value is decimal, whether the decimal point output?

Digit Place: **2**

Data Type: **Output Integer (Data x 100)**

Data Test: **0.000000**

Test Result:

Start Symbol Start Symbol Length: **2**

Byte0 30 00 00 00 00 00 00 00 00 00 00 00 00 00 00

T 0

Gap Symbol Gap Symbol Length: **1**

Byte0

OK Cancel

Reference

Please refer to Section 8.2 for the detailed setup for the private code for RS485.

◆ PLC Link

Through PLC link, you can establish communication directly with the PLC. The current version of the DMV2000 supports only the Delta PLC connection. Configure the **Start Address**, **Complete Flag**, **Timeout**, and **ID** to complete the connection setting.

The screenshot shows the 'Protocol Setting' dialog box. On the left sidebar, the 'RS485' button is selected. The main configuration area is as follows:

- Data Format:** 16 Bits
- Protocol:** Private Code, PLC Link
- Detail Setup:**
 - PLC Manufacturer: Delta Electronics
 - PLC Type: NONE
 - Start Address: 1000 H
 - Complete Flag: 1100 H
 - Timeout: 10.0 ms
 - ID: 1

At the bottom right, there are 'OK' and 'Cancel' buttons.

Reference Please refer to Section 8.3 for the detailed setup for the PLC link for RS485.

3.4.4 Display Setting

Configure the inspection display requirements through the controller.

◎ Screen Resolution

The current controller supports a screen resolution of only 1920*1080; 1024*768 is currently not supported.

© Show Ruler

Displays a ruler as a visual aid on the camera capture screen.



3.4.5 Environment Setting

Set the storage option for the common system settings for the controller. This always consists of only two storage options: storing the common system settings for all inspection projects in either the controller or the inspection project.

Select the controller internal memory, or the project to be inspected, click **Load**, and save to complete the inspection project setup.

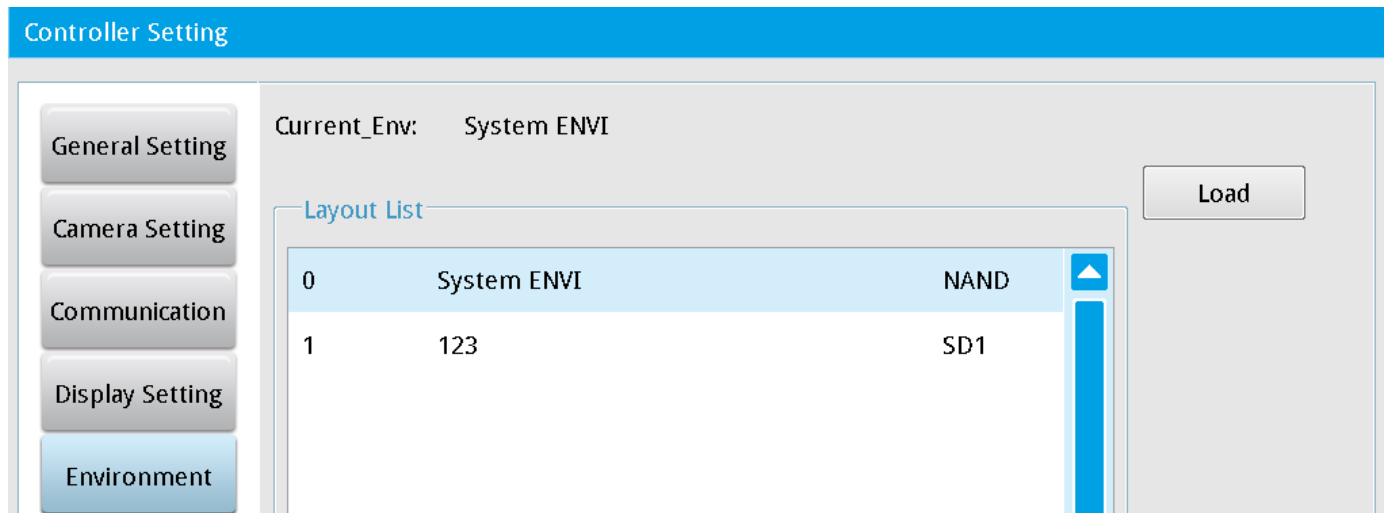

3.4.6 System Info.

This displays the current system data for the controller, including version, number and model of the connected camera(s), and the storage capacities of controller internal memory and MicroSD card memory. On the Main window, click **System**, and then click **System Info** to display the system information.

◎ **Controller Version**

The following data on the software version are displayed.

- **MCU Version:** Micro Controller Unit
- **DSP Version:** Digital Signal Processor
- **FPGA Version:** Field Programmable Gate Arrays

◎ Camera Information

Depending on the model, the DMV2000 can support two, four, or eight cameras. This shows the number and models of cameras connected to the controller.

◎ SD Information

➤ SD Card 1

This displays the remaining capacity of the memory card/the total capacity of the memory card.

Click **Format SD card** to format the SD card and erase all data on the SD card.

➤ NAND

This displays the remaining capacity of the controller internal memory/the total capacity of the controller internal memory.

The screenshot shows the 'Controller Setting' web interface. On the left is a vertical menu with buttons for 'General Setting', 'Camera Setting', 'Communication', 'Display Setting', 'Environment', 'Security Setting', 'System Info.', and 'Software Update'. The 'System Info.' button is highlighted. The main content area displays the following information:

- Delta DMV2000 Device.
- Copyright (c) 2014-2020 DELTA CORPORATION, All rights reserved.
- MCU Version: 01.00.0257
- DSP Version: 01.00.0145
- FPGA Version: 01.12.0000
- Camera Information**
 - Camera 1: DMV-CM4MCCL
 - Camera 2: None
 - Camera 3: None
 - Camera 4: None
- SD Information**
 - SD Card1: 15089.656 MB / 15189.500 MB
 - NAND: 4081.813 MB / 4094.000 MB

A 'Format SD card' button is located to the right of the SD Card1 information. At the bottom right of the interface are 'Save' and 'Exit' buttons.

3.4.7 Software Update

⊙ **Quick Update**

Determines whether the current inspection project and controller version can be updated (MCU, DSP, FPGA).

⊙ **Full Update**

Directly updates the current inspection project and controller version (MCU, DSP, FPGA).

⊙ **Restore**

Restores the previous configured version before software updating (MCU, DSP, FPGA).

Chapter 4

Inspection System and Process Settings

The DMV2000 configures the inspection system using a flow scheme. After you set the relevant parameters based on each process icon through the processing steps, you can quickly create the required inspection system project.

Depending on the model, the DMV2000 can connect two, four, or eight cameras. Therefore, a single project can execute up to eight parallel inspection processes. Additionally, the controller can store up to 1000 built-in projects in the internal memory, and up to 9999 projects in a MicroSD card. You can add, delete, copy, rename, and switch projects.

This chapter explains how to edit the settings for the inspection process.

4.1 Process Editing and Setting

After adding a new Project, you configure the flow process according to the number of connected cameras needed for the inspections.

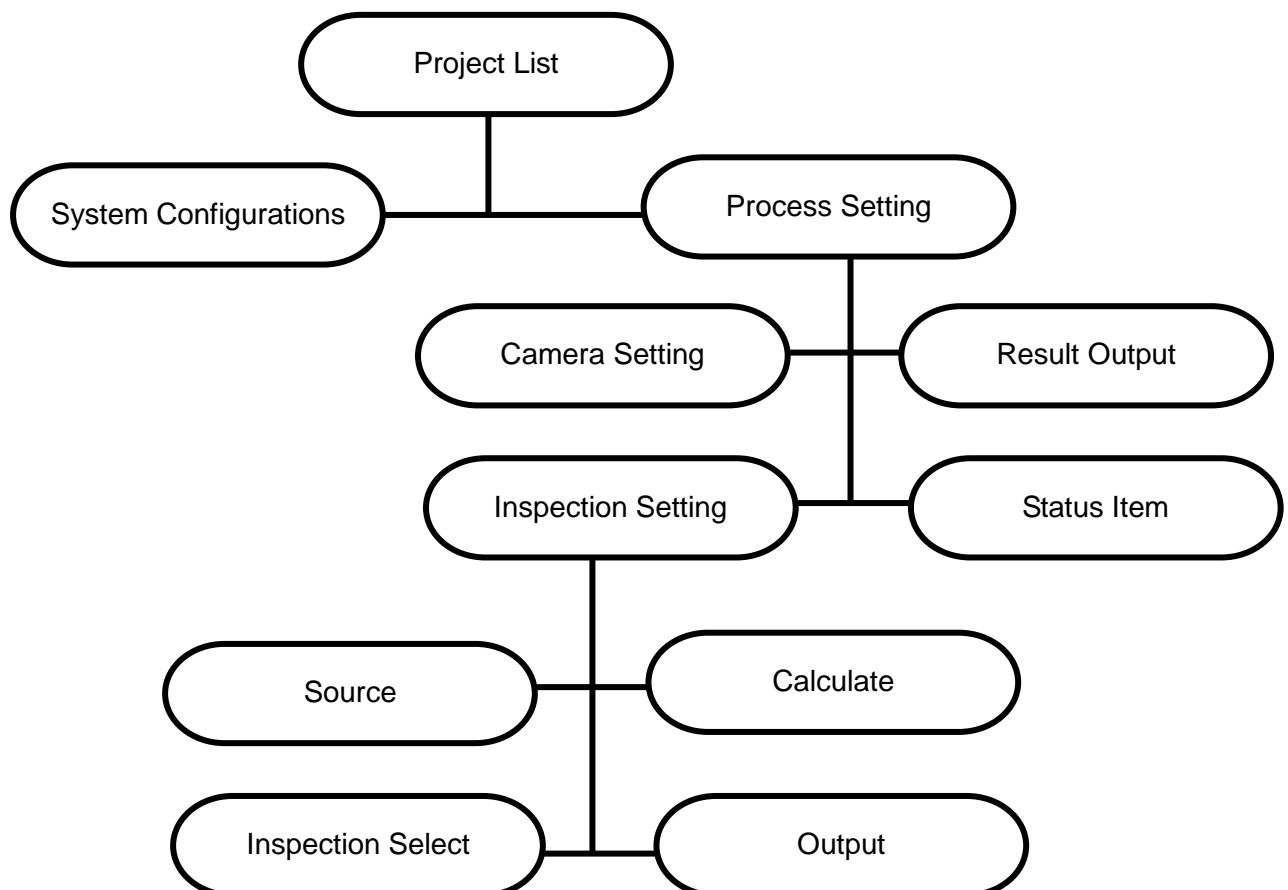

4.1.1 Add Project

Each complete inspection requirement is an individual project. A new project is created specifically for the inspection requirements for different test subjects, and the project settings do not overlap.

For example, the two projects “Perform Edge Position and Edge Angle for Inspection Object A” and “Area and Stain for Inspection for Object B” require different inspections and therefore have separate inspection projects.

4.1.2 Inspection Process Setting

Each project can simultaneously execute 1–8 processes. You configure the number of parallel processes when you add a new project. A single process must include a Camera, Inspection, Result Output, and Status Item and may contain up to 1000 Inspections. It may also contain optional Calculate steps.

I. Flow Process Page

When configuring flow processes, pay attention to the colored indicator on the right side of the flow boxes and Process Icons, described below. See the picture below the following descriptions.

⦿ Colored Indicator on the Right Side of the Flow Box

The colored indicator in the upper right corner of a box in the flow indicates the status for that step. Orange indicates incomplete settings; gray indicates that the settings are complete; red indicates a NG inspection result; and blue indicates an OK inspection result.

⦿ Flow Box

Click a flow box to add, delete, rename, copy, or paste inspections. The order of the flow boxes directly relates to the sequence of execution.

⦿ Process Icon

Click a process icon to edit the individual option settings.

The following picture shows a single inspection project running 2 parallel inspection processes.

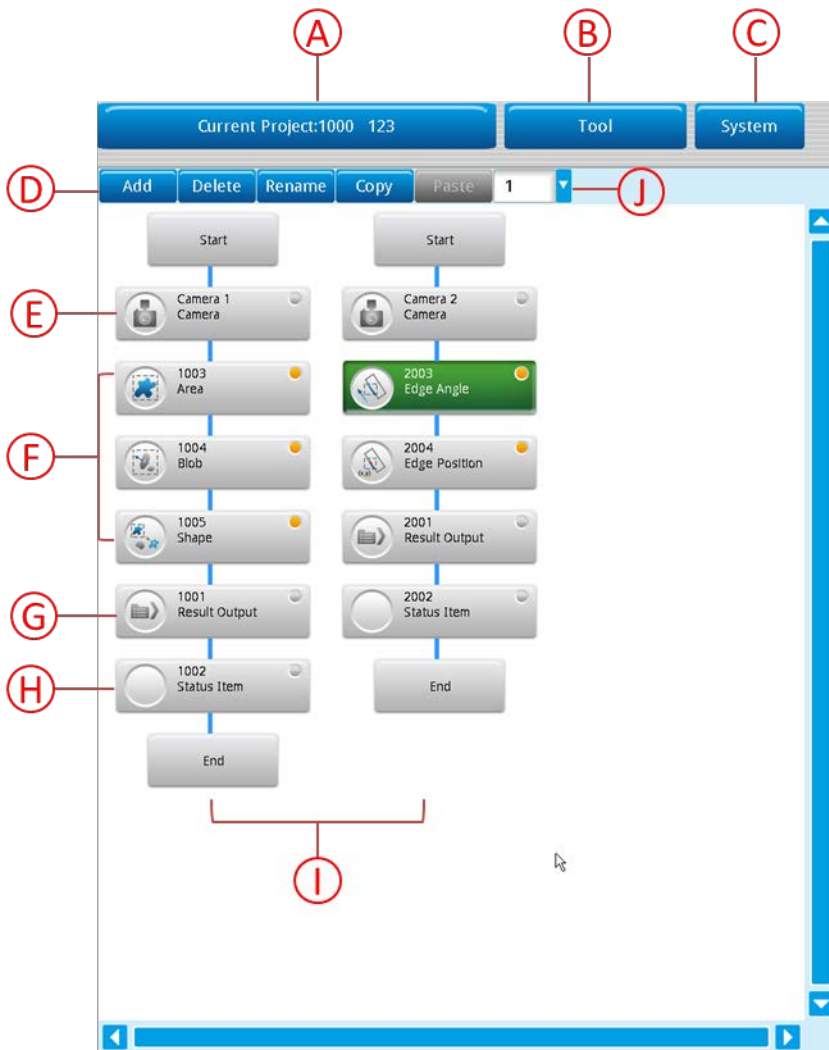

A. Current Project

Displays the current project name. Project settings apply to only the current project.

 **Reference** Please refer to Section 3.2 for detailed descriptions of the project settings.

B. Tool

Tools provide the mode and basis for executing project inspection. The commands on the Tools menu include Register Image Management, Run Mode Screen Editing, and Judge Setting. Tool menu command settings apply to only the current project.

 **Reference** Please refer to Section 3.3 for detailed descriptions of the tool settings.

C. System

The System settings consists of several configuration functions, including the General Setting, Camera Setting, Communication Setting, Display Setting, Environment Setting, Security Setting, and Software Update. System settings apply across all projects.

 **Reference** Please refer to Section 3.4 for detailed descriptions of the system settings.

D. Add, Delete, Rename, Copy, Paste

A single inspection process may contain several inspections. These buttons allow you to easily create and edit inspections.

Add: adds 1 inspection.

Delete: deletes the selected inspection.

Rename: renames the selected inspection.

Copy: copies the selected inspection.

Paste: pastes the copied inspection.

E. Camera

Specifies the camera for the inspection process, and includes seven configuration items: Camera Setting, White Balance, ROI, Trigger Setup, Flash Setup, Register Image, and CCM Status.

Flow camera setting captures images from the connected cameras, which can be either color or gray-scale. After connecting to a camera, the controller prompts whether to automatically detect and upload the camera model and specifications. You can configure a flow camera according to inspection requirements, or you can use the system settings by selecting the **Reference System Setting** check box when you configure the camera.

 **Reference** Please refer to Section 4.2 for detailed descriptions of the camera settings.

F. Inspection

You add inspections to your project depending on your inspection requirements. A single inspection process can contain up to 1000 inspections. You set the order of inspections during project execution by clicking the desired position in the inspection flow, and then clicking **Add, Delete, Rename, Copy, or Paste**.

Click the icon on the left side of an inspection box to set up the eight inspection settings: Image Select, ROI, Color Condition, Preprocess, Parameter, Limit, Locate, and Execute. Color Condition is not required for gray-scale cameras.

 **Reference** Please refer to Chapter 5 for the detailed descriptions of the inspections.

G. Result Output

Specifies the processing of the desired inspection result output and includes: Device Choose, Data Output Priority, and When No Storage.

 **Reference** Please refer to Section 6.3 for the detailed descriptions of the result output.

H. Status Item

Select the inspection to be judged (OK/NG) during run mode.

 **Reference** Please refer to Section 6.4 for the detailed description of the status item.

I. Parallel Flow

A project can execute up to eight parallel processes depending the number of cameras connected to the controller and the inspection requirements.

J. Parallel Flow Number

You can configure up to eight inspection processes in a single inspection project. This displays the inspection flow number.

II. Edit Flow

After you complete the System settings that apply to all projects, you can configure the inspection flow process. You configure the inspection flow process based on the individual project inspection requirements, and configure the inspection flow through the connected camera(s).

Use the following order when configuring a flow process: **Camera** setting > **Inspection** setting > **Result Output** > **Status Light**.

☉ Camera

Click the icon next to the Camera box to enter and configure the following settings for the camera.

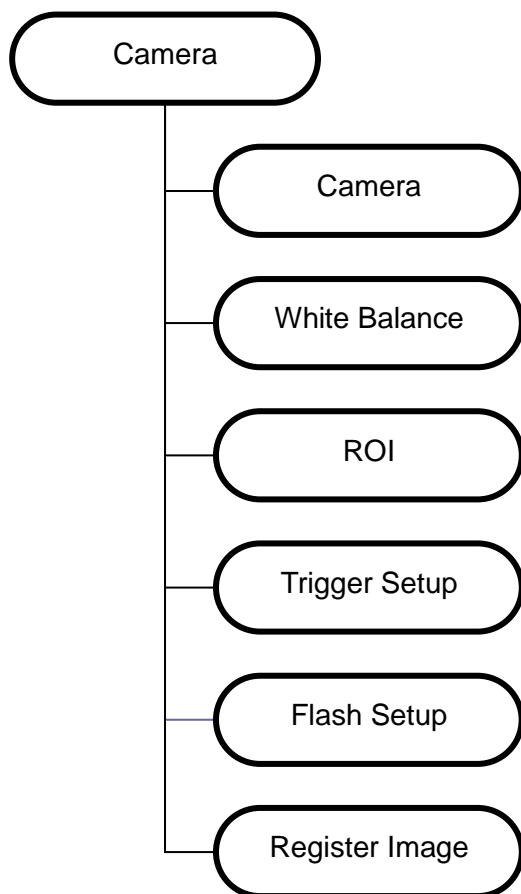

 **Reference** Please refer to Section 3.4.2 for the steps to set up Camera, White Balance, ROI, Trigger, and Flash. Please refer to Section 3.3.1 for the steps to set up Register Image.

© Add Unit

➤ Source

Selects the camera source. Depending on the model, the DMV2000 can connect up to eight cameras (**Camera 1–Camera 8**).

➤ Inspection

This is the core of the project. You configure this according to the inspection requirements. A single process can include up to 1000 inspections, and the order of the inspections parallels the sequence of the inspection project execution. Select the item in the process and click **Add** to add an inspection.

The DMV2000 includes 20 inspection functions, and currently supports 17 functions: Area, Blob, Stain, Edge Angle, Edge Count, Edge Pitch, Edge Position, Edge Width, Shape, Intensity, Position Trace, Width Trace, OCV, Bar Code, 2D Bar Code, 1P Position, and 1P Location.

To complete adding a new inspection, click the icons on the left side of the inspection box to configure Image Select, ROI, Color Condition, Preprocess, Parameter, Limit, Locate, and Execute.

 **Reference** Please refer to Chapter 5 for detailed descriptions of the inspection settings.

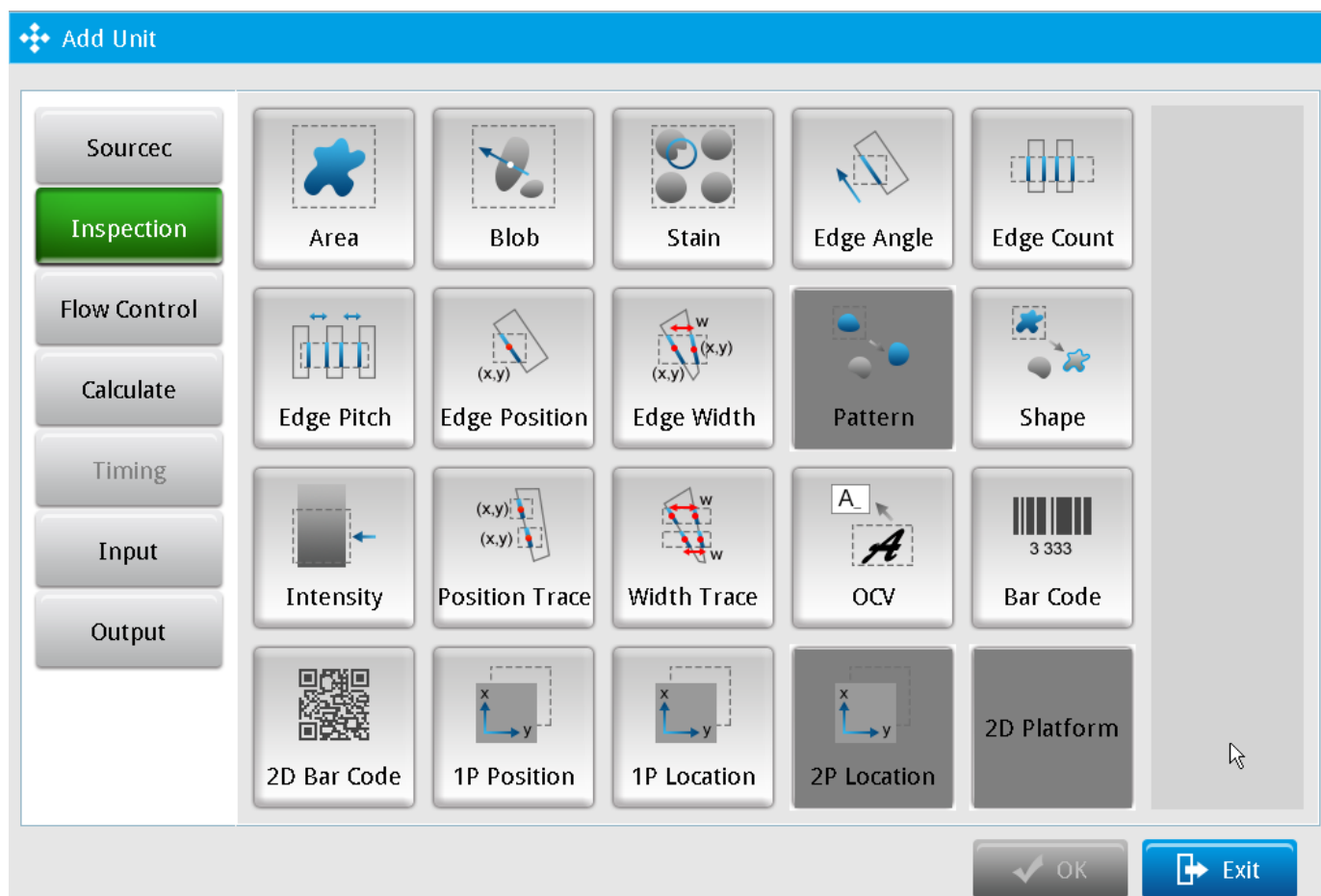

► Calculate

Apply fundamental arithmetic operations and function calculations on the data from the Inspection to obtain new data, which is then provided to subsequent Output options. In addition, you can restrict this new data with the upper and lower limits you set in the calculator to output the calculator-specific logic flag, and pass this result to the subsequent Judge and Output processes.

 **Reference** Please refer to Chapter 6 for detailed descriptions of the calculation settings.

► Output

You can choose to output the resulting numeric data from Inspection and Calculate, as well as the logic flags from Inspection, Calculate, and Judge, through any communication interface as described below.

- ◆ **Image Output:** Select one or more hardware interfaces (Ethernet or SD card) to output the resulting data. Next, for the **Condition**, click **Detail Setup** and select the desired inspection output (OK/NG) screen during project execution.

The following picture shows the **Image Output** dialog box.

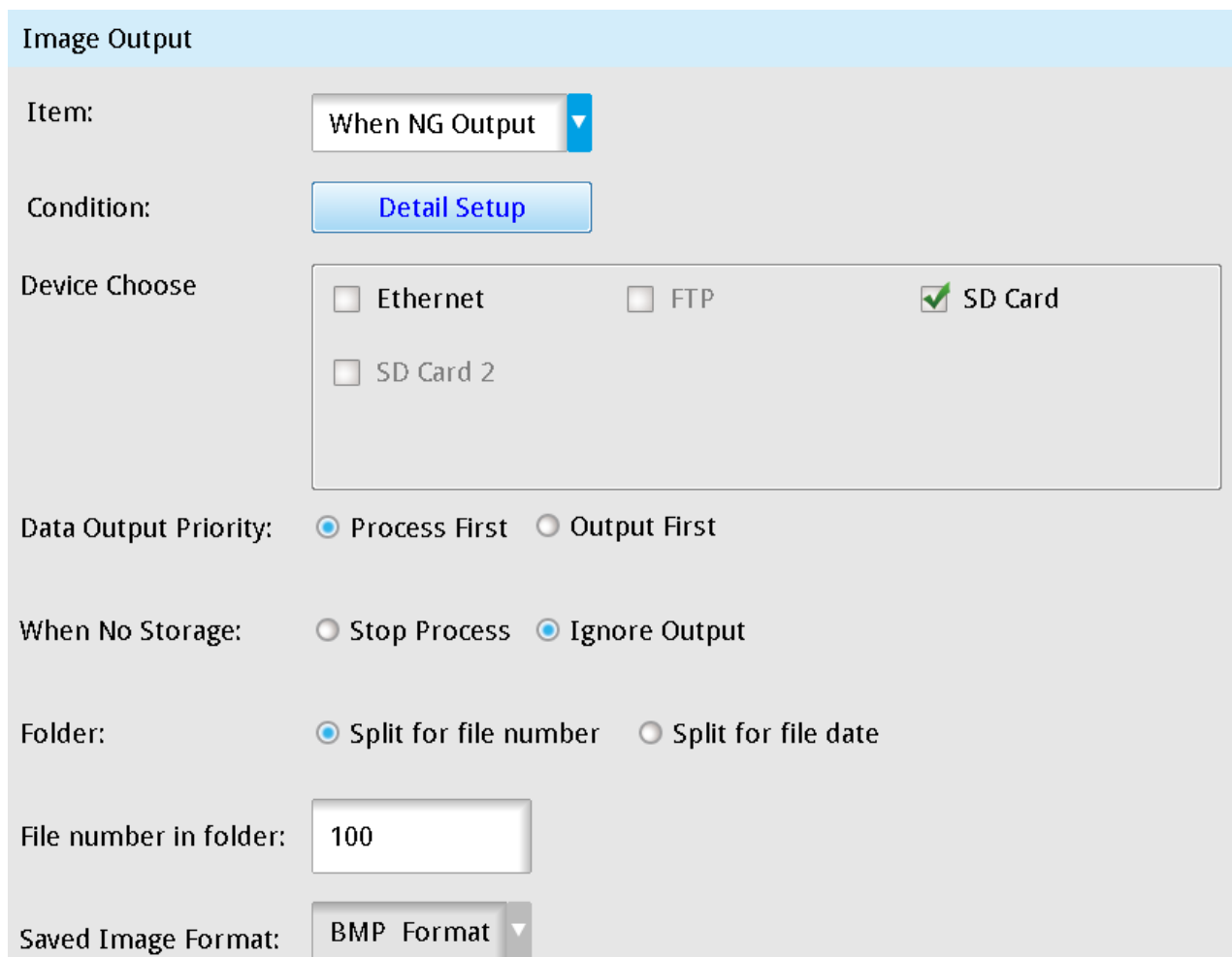

Image Output

Item: When NG Output ▼

Condition: [Detail Setup](#)

Device Choose

Ethernet FTP SD Card

SD Card 2

Data Output Priority: Process First Output First

When No Storage: Stop Process Ignore Output

Folder: Split for file number Split for file date

File number in folder: 100

Saved Image Format: BMP Format ▼

Item

Specifies whether to output the image when OK or NG.

Condition

Specifies the inspection for the output image.

Device Choose

Specifies the hardware interface for the output image: **Ethernet** or **SD Card** or both.

Data Output Priority

Specifies the image output priority: Process First or Output First.

- **Process First:** Continue project inspection before completing output to the SD card.
- **Output First:** Pause triggered project inspection until completing output to the SD card.

When No Storage

Specifies the action when there is not enough memory for the image output: **Stop Process** or **Ignore Output**.

File Number in Folder

Specifies the storage method: **Split for File Number** or **Split for File Date**.

Number of Folders

Specifies the maximum number of files in a folder. Configured Value: 0–99999999.

Saved Image Format

Specifies the image format: BMP format.

◆ Internal Memory

The DMV2000 provides 32 internal registers. You can configure Constant, Judge Value, and Inspection Result Value, and directly load these configured values in an internal register in the Calculate tool.

Constant

Sets a fixed value.

Judge Value

Selects the item (inspection result) Judge value: inspection result OK = 1 or NG = 0

Inspection Result

Selects the inspection result for numerical values.

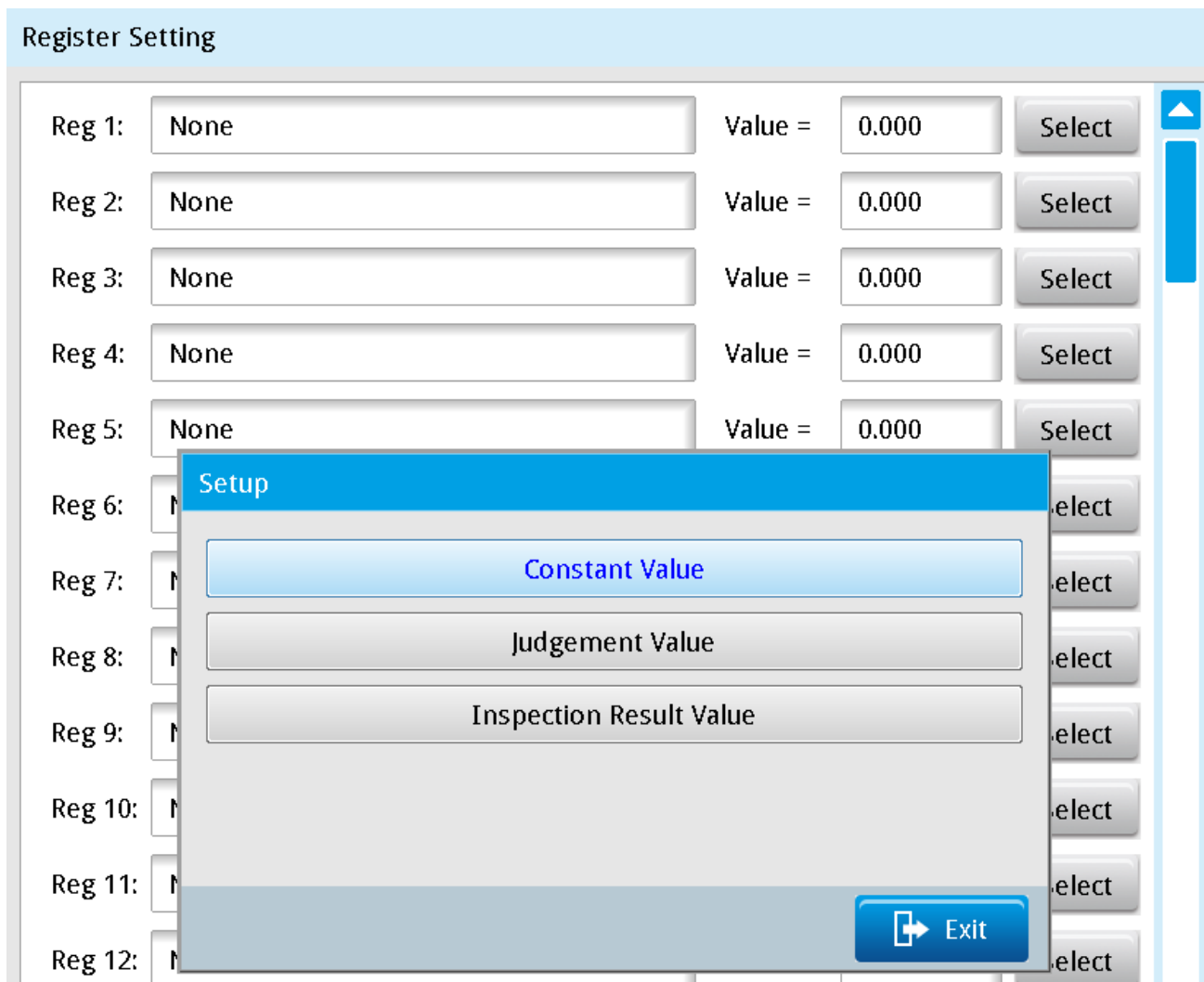

◎ Result Output

In the **Result Output** dialog box, click **Detail Setup** to define the processing of the desired inspection result output, and configure the following: Device Choose, Data Output Priority, and When No Storage.

Result Output -

Item: Start Address: H

<input checked="" type="checkbox"/>	ID	RS232	RS485	Item
<input checked="" type="checkbox"/>	0	1010	1010	W1003.Area
<input checked="" type="checkbox"/>	1	1011	1011	W1004.Blob

Device Choose

RS232 RS485 FTP
 Ethernet SD Card SD Card 2
 External Terminal

Data Output Priority: Process First Output First

When No Storage: Stop Process Ignore Output

Remark Click **Recovery** to restore initial settings. Click **Save** to save all modified parameters and values. Click **Exit** to leave the dialog box.

➤ **Data Output Priority**

When you select the **RS232** or **RS485** check box:

- **Process First:** the result is not output through **RS232**, **RS485**, **Ethernet**, **SD Card**, and **External Terminals** before output to the SD card completes.
- **Output First:** Stop reception triggering until the SD card completes output

➤ **When No Storage**

1) When you select the **RS232** or **RS485** check box:

- **Stop Process:** When the remaining capacity runs out of space during SD card output, a warning message appears and the process stops.
- **Ignore Output:** When the remaining capacity runs out of space during SD card output, the inspection continues but is unable to store the result.

2) When you select the **SD Card** check box:

- **Stop Process:** When the register runs out of space during SD card output, warning window appears and process stops.
- **Ignore Output:** When the register runs out of space during SD card output, the inspection continues but is unable to output result.

© Status Item

Click **Detail Setup**, then select the **Item** (inspection) to be judged (OK/NG) during run mode.

Status Item

Item: Detail Setup

<input checked="" type="checkbox"/>	ID	Item
<input checked="" type="checkbox"/>	0	W1003.Area
<input checked="" type="checkbox"/>	1	W1004.Blob

Save Exit

4.2 Flow Process Camera Setting

You configure the flow process camera according to the individual inspection project requirements. The System camera settings apply to all the cameras connected to the controller. The System camera makes it easy to quickly set up a flow process camera when adding new projects. In the flow process camera setting, you can load the system camera setting, or reset all the settings.

◎ Camera Setting

You configure the flow process camera specifically for a single flow process in an individual project. Depending on the model, the DMV2000 can connect up to eight cameras, so you can configure up to eight flow process cameras in an inspection project. Each camera is either color or gray-scale. After connecting to the camera, the controller prompts you whether to automatically detect the camera model and upload the specifications.

Camera 1

Camera Setting

White Balance

ROI

Trigger Setup

Flash Setting

Register Image

CCM

Select Working Camera

Camera 1 ▼

Refence System Setting

Camera Model: DMV-CM4MCL

Camera Mode: 24bit Color

Resolution : 4.00 Megapixels

Frame Rate : FPS 39

Shutter Speed : User Define ▼ 2048 us

Gain: 0

Luminance: 0

Clamp: 40

Distance per Pixels: 1.000

HDR Enable: Enable

HDR parameter1: 1

➤ **Reference System Setting**

If you select this check box, the system loads the configured values from the System configuration.

➤ **Camera Model**

The controller reads this from the camera.

➤ **Camera Mode**

The controller reads this from the camera.

➤ **Resolution**

The controller reads this from the camera.

➤ **Frame Rate**

The controller reads this from the camera.

➤ **Shutter speed**

Select the shutter setting (the default is user defined) from a list. A longer shutter time increases the exposure and the amount of light absorbed and is useful when there is insufficient lighting.

➤ **Gain**

Range: 0–255; a higher gain results in a brighter image but the image may contain more noise.

➤ **Luminance**

Range: 0–10; a higher brightness results in a brighter image but the actual luminosity variation is less than the gain adjustment.

➤ **Clamp**

Range: 0–255; a higher Clamp value results in a brighter image but actual luminosity variation is less than the luminance adjustment.

➤ **Distance/Pixel**

The ratio between the on-screen pixels and actual distance; the units of pixels are converted to actual units.

➤ **HDR**

Range: 0–254; high dynamic range is only suitable for gray-scale cameras; a low parameter value results in a low exposure and can only develop whitish and overexposed outlines; regions of denser black pixels on the original image become darker.

◎ White Balance Setting

Restores the colors of the selected image and calibrates the colors. Drag the white balance region to the position on the screen that should be white, and then click **Auto Setting**. The following picture is before applying white balance.

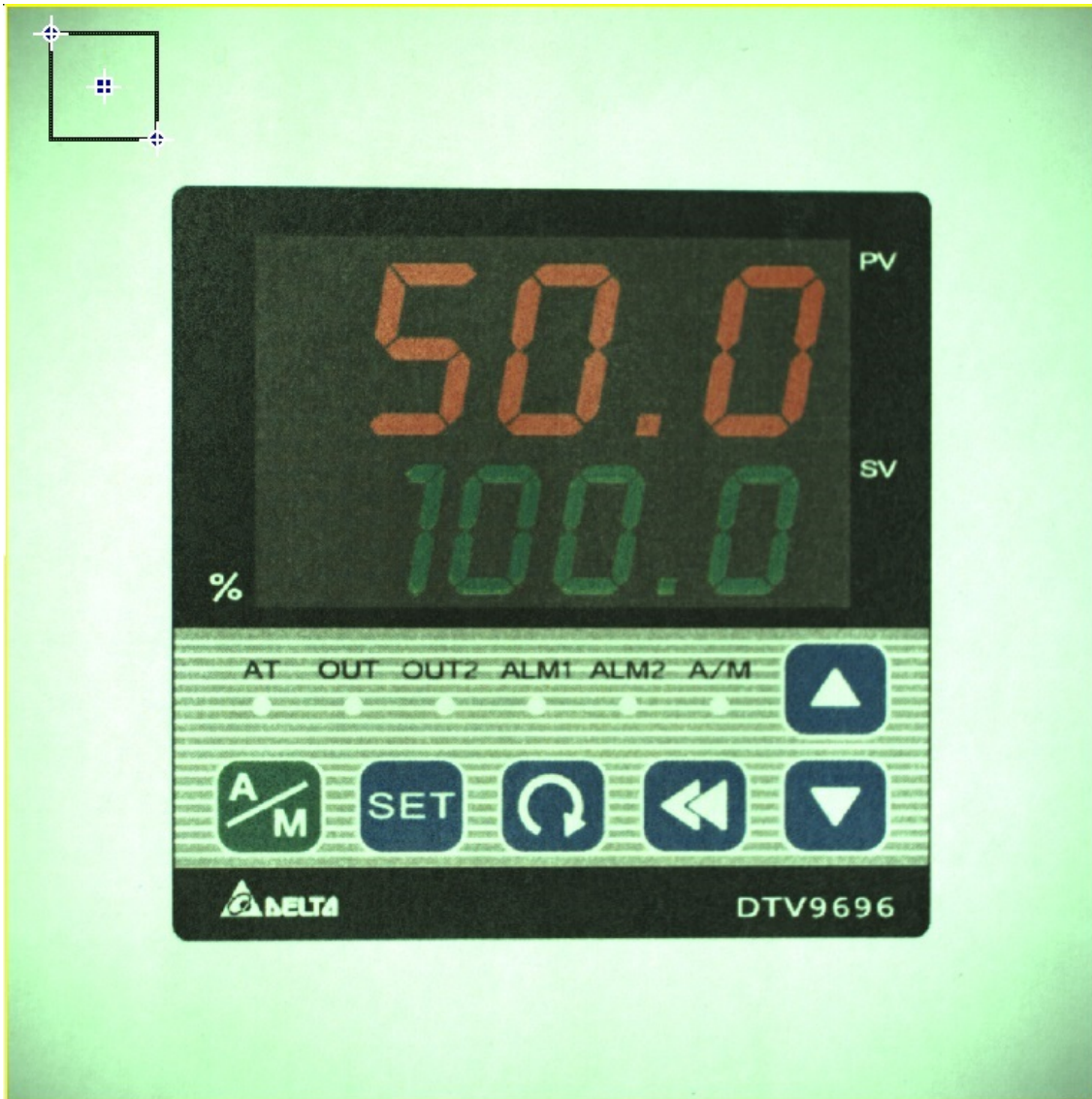

- ▶ The following picture is after applying white balance calibration.



- ▶ **Inspection Region**

Displays the X and Y coordinates (X0, Y0) and (X1, Y1) of the white balance region; the image shows the deviation from the color tone, corrected based on the white reference of the region.

Remark Click **Reset** to reposition and resize the selected region for white balance.

- ▶ **Average RGB in Region**

Calculates the RGB values for pixels in the selected region for white balance.

► White Balance Coefficient

Range: 0–1; a larger value results in a higher color density. When the three values obtained by multiplying the white balance coefficient by the RGB average within the region are similar, the color within the inspected region is close to white.

Remark Click **Auto Setting** and the system automatically adjusts the white balance coefficient according to the selected region.

◎ ROI

Captures images in the selected region of interest. This saves image processing time during inspections and measurements. You can adjust the size of the inspection region according to the application.

◎ Trigger Setup

There are five ways to set up the trigger for the inspection processes: external terminal, internal trigger, Ethernet, RS-232, and RS485. A single inspection process can be triggered by up to four types of triggers.

Trigger Type:	Trigger1(Terminal)
Trigger Type:	Terminal
Interval (ms):	Internal Trigger
Trigger Delay (ms)	Terminal
Configuration:	Ethernet(TCP/IP)
	RS-232
	RS-485

Detail Setup:	
Trigger Type:	Trigger1(Terminal)
Trigger Type:	Trigger1(Terminal)
Interval (ms):	Trigger2(Terminal)
Trigger Delay (ms)	Trigger3(Terminal)
	Trigger4(Terminal)
Configuration:	

► Reference System Setting

If you select this check box, the system loads the settings from the System configuration.

► External Trigger

Trigger by external device through varying interfaces: a single inspection process can be triggered by up to four types of triggers.

- 1) **External Terminal:** input trigger signal using I/O to execute process inspection.
- 2) **RS232:** input communication command through the serial interface to execute process inspection.
- 3) **RS485:** input communication command through the serial interface to execute process inspection.
- 4) **Ethernet:** input communication command through the Ethernet interface to execute process inspection.

► Internal Trigger

You can only set the Internal Trigger on Trigger 1. This automatically triggers according to the configured time and is suitable for applications requiring timed inspections. It includes both **Interval (ms)** and **Trigger Delay (ms)** settings for timed inspections.

The following picture shows a configuration for Triggers 1–4.

Configuration:

Reference System Setting

Flow Chart	1	2	3	4	5	6	7	8
Trigger1	<input checked="" type="checkbox"/>	<input type="checkbox"/>	<input type="checkbox"/>	<input type="checkbox"/>	<input type="checkbox"/>	<input type="checkbox"/>	<input type="checkbox"/>	<input type="checkbox"/>
Trigger2	<input checked="" type="checkbox"/>	<input type="checkbox"/>	<input type="checkbox"/>	<input type="checkbox"/>	<input type="checkbox"/>	<input type="checkbox"/>	<input type="checkbox"/>	<input type="checkbox"/>
Trigger3	<input checked="" type="checkbox"/>	<input checked="" type="checkbox"/>	<input type="checkbox"/>	<input type="checkbox"/>	<input type="checkbox"/>	<input type="checkbox"/>	<input type="checkbox"/>	<input type="checkbox"/>
Trigger4	<input type="checkbox"/>	<input checked="" type="checkbox"/>	<input type="checkbox"/>	<input type="checkbox"/>	<input type="checkbox"/>	<input type="checkbox"/>	<input type="checkbox"/>	<input type="checkbox"/>
Trigger5	<input type="checkbox"/>	<input type="checkbox"/>	<input type="checkbox"/>	<input type="checkbox"/>	<input type="checkbox"/>	<input type="checkbox"/>	<input type="checkbox"/>	<input type="checkbox"/>
Trigger6	<input type="checkbox"/>	<input type="checkbox"/>	<input type="checkbox"/>	<input type="checkbox"/>	<input type="checkbox"/>	<input type="checkbox"/>	<input type="checkbox"/>	<input type="checkbox"/>
Trigger7	<input type="checkbox"/>	<input type="checkbox"/>	<input type="checkbox"/>	<input type="checkbox"/>	<input type="checkbox"/>	<input type="checkbox"/>	<input type="checkbox"/>	<input type="checkbox"/>
Trigger8	<input type="checkbox"/>	<input type="checkbox"/>	<input type="checkbox"/>	<input type="checkbox"/>	<input type="checkbox"/>	<input type="checkbox"/>	<input type="checkbox"/>	<input type="checkbox"/>

Trigger1 ▼ Trigger2 ▼ Trigger3 ▼ None ▼

50.0 3.0 60.0 0.0

➤ **Reference System Setting**

If you select this check box, the system loads the settings from the System configuration.

➤ **Lower Combined Field**

Select the triggers and the trigger interval; range: 0–9999; unit in μ s.

⊙ **Flash Setup**

Flash controls the lighting output in sync with the camera shutter when capturing images. Depending on the model, the DMV2000 can connect to up to 8 cameras. Therefore you can set up to 8 flash configurations. You can set up multiple flash configurations for the same process or for different processes. The following picture shows the Flash Setting options.

Camera 1

Camera Setting

White Balance

ROI

Trigger Setup

Flash Setting

Register Image

CCM

Select Flash

Reference System Setting

Select Flash: Flash1

Enable/Disable: Enable Disable

Flash Action: After action Before action

Output Start Time: 0.0 ms During Time: 0.0 ms

Configuration:

Reference System Setting

Camera	1	2	3	4	5	6	7	8
Flash1	✓	<input type="checkbox"/>	<input type="checkbox"/>	<input type="checkbox"/>	<input type="checkbox"/>	<input type="checkbox"/>	<input type="checkbox"/>	<input type="checkbox"/>
Flash2	✓	<input type="checkbox"/>	<input type="checkbox"/>	<input type="checkbox"/>	<input type="checkbox"/>	<input type="checkbox"/>	<input type="checkbox"/>	<input type="checkbox"/>
Flash3	<input type="checkbox"/>	<input type="checkbox"/>	<input type="checkbox"/>	<input type="checkbox"/>	<input type="checkbox"/>	<input type="checkbox"/>	<input type="checkbox"/>	<input type="checkbox"/>
Flash4	<input type="checkbox"/>	<input type="checkbox"/>	<input type="checkbox"/>	<input type="checkbox"/>	<input type="checkbox"/>	<input type="checkbox"/>	<input type="checkbox"/>	<input type="checkbox"/>
Flash5	<input type="checkbox"/>	<input type="checkbox"/>	<input type="checkbox"/>	<input type="checkbox"/>	<input type="checkbox"/>	<input type="checkbox"/>	<input type="checkbox"/>	<input type="checkbox"/>
Flash6	<input type="checkbox"/>	<input type="checkbox"/>	<input type="checkbox"/>	<input type="checkbox"/>	<input type="checkbox"/>	<input type="checkbox"/>	<input type="checkbox"/>	<input type="checkbox"/>
Flash7	<input type="checkbox"/>	<input type="checkbox"/>	<input type="checkbox"/>	<input type="checkbox"/>	<input type="checkbox"/>	<input type="checkbox"/>	<input type="checkbox"/>	<input type="checkbox"/>
Flash8	<input type="checkbox"/>	<input type="checkbox"/>	<input type="checkbox"/>	<input type="checkbox"/>	<input type="checkbox"/>	<input type="checkbox"/>	<input type="checkbox"/>	<input type="checkbox"/>

➤ **Select Flash**

Select the flash to configure.

DMV2000 Digital Machine Vision Operating Manual v3.0

4-19

► **Enable/Disable**

Flash can only be turned on when you select **Enable**.

► **Flash Action**

After Action: the flash activates only after the camera shutter engages;

Before Action: the flash activates before the camera shutter engages.

► **Output Start Time**

Sets the delay time between the flash and the shutter; the timing depends on the **Flash Action** settings.

For example: if you set the value to 10 ms:

- 1) For **After Action**, the shutter first activates to capture the image after the capture trigger signal; then the flash activates after the 10 ms delay.
- 2) For **Before Action**, the flash first activates after the capture trigger signal; then the shutter activates after the 10 ms delay. This is the generally recommended method.

► **During Time**

Sets the total flash duration. To ensure that the flash can activate and hold for a certain duration when the shutter activates, set **During Time** to a value greater than the sum of **Output Start Time** and **Shutter Speed**.

 **Reference** Please refer to Section 7.2.2 for the detailed description for the camera setup.

◎ **Register Image**

When executing inspections, you must first register the image for comparison, so that the inspected image can be compared to the registered image. The Image Register manages the images for a single flow process and can store, rename, delete, and copy the images captured by the connected camera. To register an image, complete the camera configuration and then click **<<Register**. Select the **Live Update** checkbox so that the camera captures live images. You can then immediately confirm whether the camera captured an image that meets the inspection requirements.

► **Image Source**

Capture source of image register; always captures from the camera.

► **Camera**

There are no options available here; only the camera connected to the current process is displayed.

► Image List

The **Image List** displays the registered images according for each camera (**Camera 1–Camera 8**). Image ID numbers are between 1000–8000.

All: Select this check box to include the images from all cameras connected to the controller in the Image List.

Rename: renames the selected image.

Delete: deletes the selected image.

Copy: copies the selected image. After you click **Copy**, enter the **Destination Image Name** and the **Number** of copies you want to make.

- 1) If making more than two copies, "-1" and "-2" is appended to the name of the copies. For example, if the original image is named "ABC" and the Destination Image Name for the copy is "XXX" and the number of copies is set to 3, the three copied images are named "XXX-1", "XXX-2", and "XXX-3".
- 2) If making a single copy, "-1" is not added. If the original image is named "ABC", the Destination Image Name is "XXX" and the number of copies is set to 1, the copied image is named "XXX".

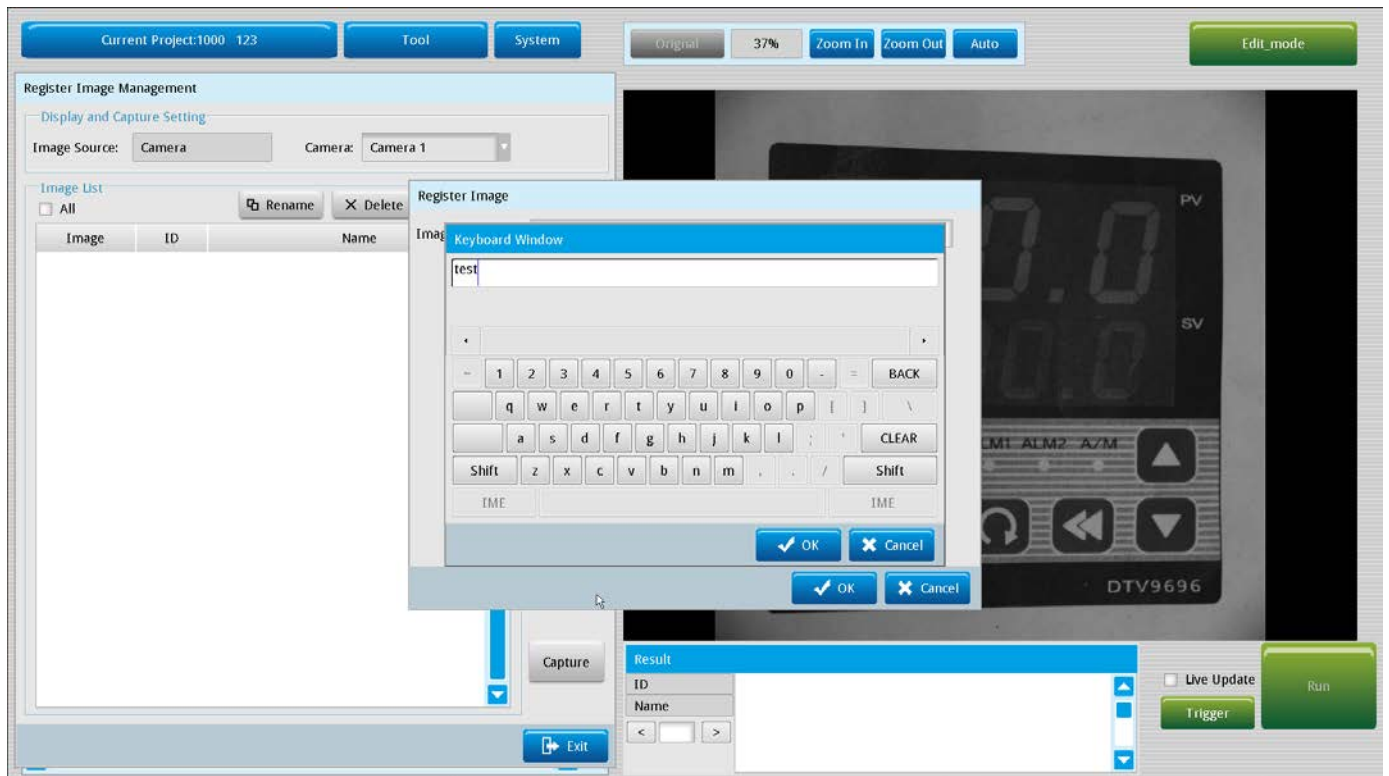

After you click **OK**, the Image List includes the registered image.



4.3 Draw ROI

When creating a new inspection, you must use the mouse to click-and-drag to select the range of the image to be inspected, which is commonly referred to as ROI (region of interest). You can configure the ROI as follows:

- Configure the settings in **Inspection > ROI > Region**
- Configure the settings in **Inspection > ROI > Region Mask**

You can use any of the following shapes when defining the ROI:

- Rectangle
- Circle
- Polygon
- Ellipse
- Circle
- Arc
- Rotated rectangle

4.3.1 Draw a Rectangle

Follow the steps below to draw a rectangle.

- 1) The initial state of a rectangle shows the central crosshair and the two upper and lower corners. Drag the central crosshair of the rectangle to move the entire object.

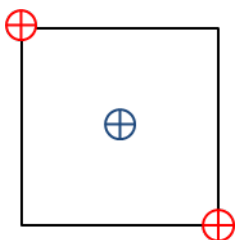

- 2) Drag the upper left crosshair to adjust the position of the upper corner and select the inspection region.

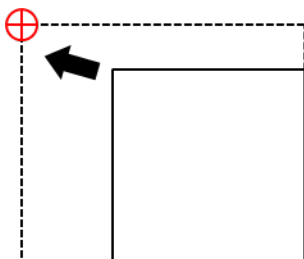

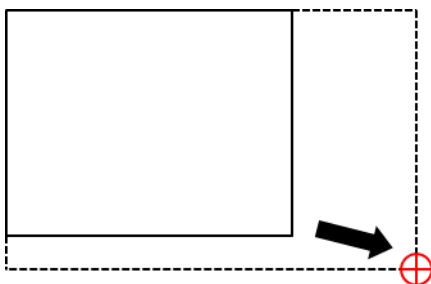

- 3) Drag the lower right crosshair to adjust the position of the lower corner and select the inspection region.



- 4) Finally, click the central crosshair or the  button to complete setting the coordinate positions of the rectangle.

5) You can use steps 1-4 in coordination with the data in the right column to adjust the numerical values for the rectangle. See the following picture.

Rectangle			
Center	897	960	
Left/Top	129	208	
Right/Bottom	1665	1713	

Remark Click  to restore the initial configured value. Click  to use the maximum range for the ROI.

4.3.2 Draw a Circle

Follow the steps below to draw a circle.

1) The initial state of a circle shows the central crosshair and four circumference points at the top, bottom, left, and right. Drag the crosshair at the center of the circle to move the entire object.

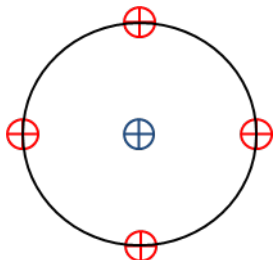

2) Drag any circumference point to adjust the point position and select the inspection range.

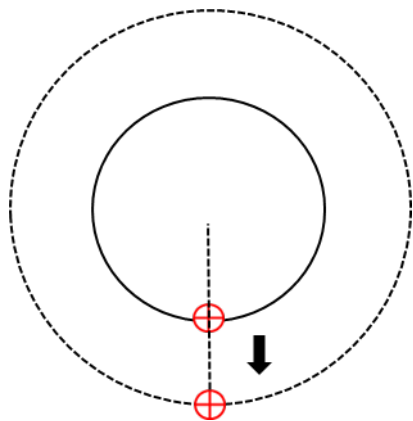

3) Finally, click the central crosshair or the  button to complete setting the coordinate positions of the circle.

4) You can use steps 1–3 in coordination with the data in the right column to adjust the numerical values for the circle. See the picture below.

Circle	
Center	900 1024
Radius	830

Remark Click  to restore the initial configured value.

4.3.3 Draw a Polygon

Follow the steps below to draw a polygon (up to a maximum of 15 sides—a pentadecagon).

1) The initial state of a polygon shows the central crosshair, there vertices, and three edges. Drag the crosshair at the center of the polygon to move the entire object.

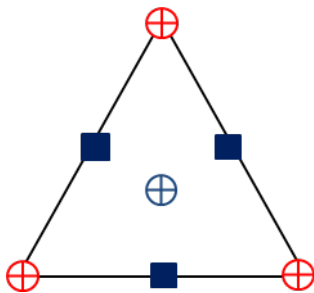

2) Click any one vertex (first vertex), and then move the mouse pointer to adjust the vertex position and inspection range, and then click the mouse button again to locate the vertex in the new position. Note that this is different from moving a vertex in the previous shapes.

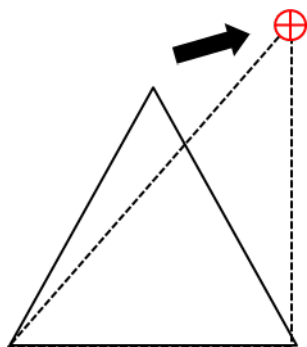

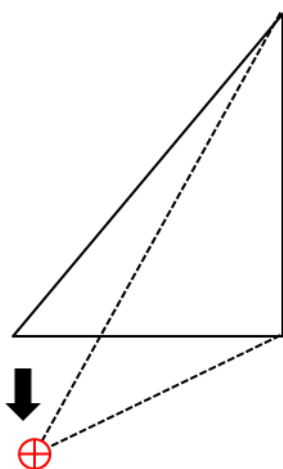

- 3) Click any one vertex (second vertex), and then move the mouse pointer to adjust the vertex position and inspection range, and then click the mouse button again to locate the vertex in the new position.

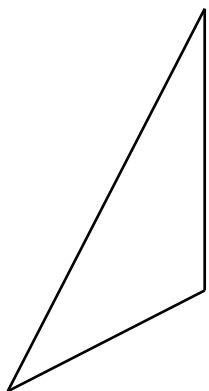

- 4) After locating all vertices in the desired inspection region, you can adjust each vertex position and coordinate display according to the table of numerical values in the right column of the table (see the picture after the steps).



- 5) Click the  on any edge to add a fourth vertex, and then move the mouse pointer to place the new vertex position and inspection range, and then click the mouse button again to locate the new vertex. You

can also click  in the table to the right to add a new vertex from each vertex position.

6) Use steps 1–4 to adjust the polygon to the required area.

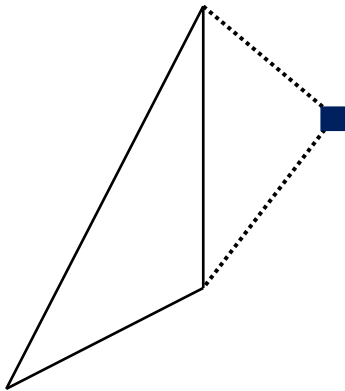



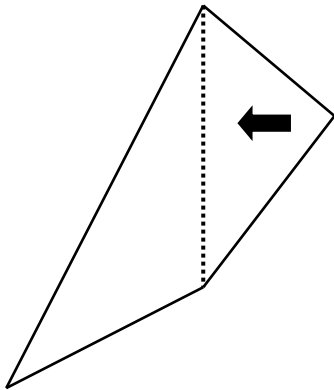

















7) You can delete a vertex by right-clicking the vertex to be deleted, or click  in the table to the right of the vertex to delete (see the picture of the Polygon settings below).



8) Finally, click the central crosshair or click the  button to complete setting the coordinate positions of the polygon.

9) You can use steps 1–8 in coordination with the data in the right column to adjust the numerical values for the polygon.

Polygon							
Center	967		991				
Pt01	1023		512				
Pt02	1467		1279				
Pt03	580		1280				
Pt04	801		896				

 **Remark** Click  to restore the initial configured value.

4.3.4 Draw an Ellipse

Follow the steps below to draw an ellipse.

1) The initial state of an ellipse shows the central crosshair, the small square in the ellipse, the straight line, and the bottom and left circumference vertices corresponding to the position of the small square. Drag the crosshair at the center of the circle to move the entire object.

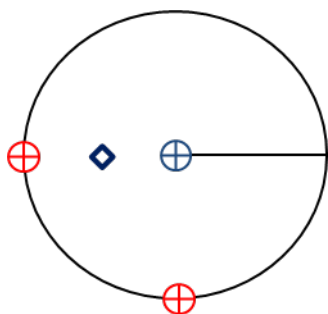

2) Drag one vertex to adjust the width of the ellipse in the corresponding direction.

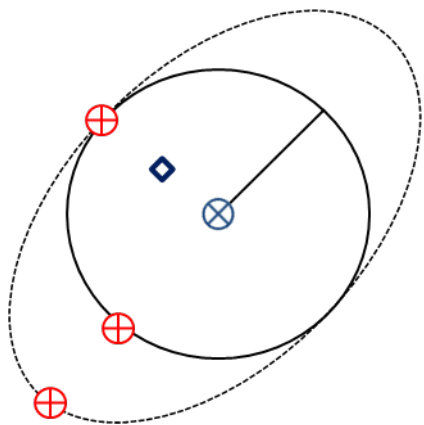

3) Drag the other vertex to adjust the width of the ellipse in the other direction.

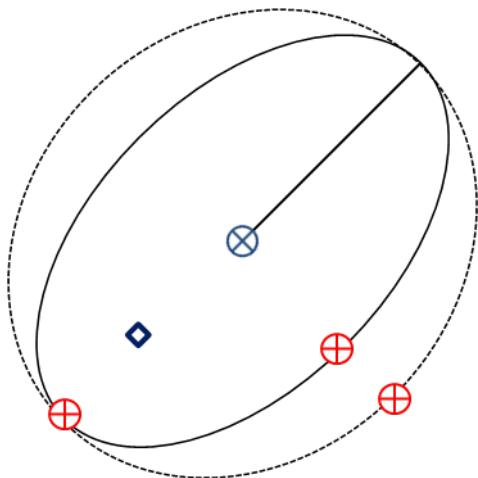



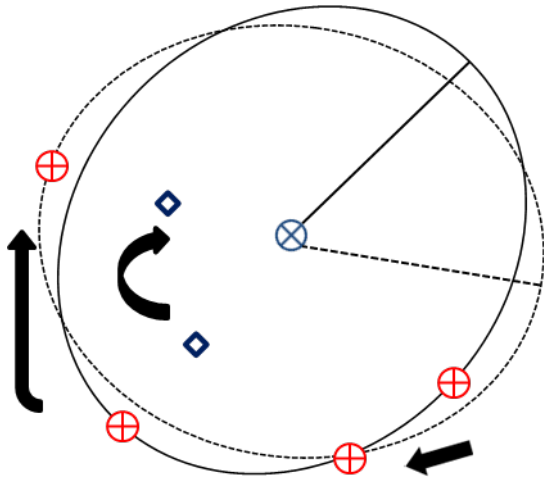











4) Drag the small square inside the ellipse to rotate the angle of the ellipse.



5) Finally, click the central crosshair or click the  button to complete setting the coordinate positions of the ellipse.

6) You can use steps 1–5 in coordination with the data in the right column to adjust the numerical values for the ellipse. See the picture below.

Ellipse			
Center	900	 	912  
Horizontal Axis	538		 
Vertical Axis	574		 
Angle	22		 

Remark  Click  to restore the initial configured value.

4.3.5 Draw a Ring

Follow the steps below to draw a ring.

1) The initial state of the ring shows the central crosshair, four inner ring circumference vertices, and four outer ring circumference vertices. Drag the crosshair at the center of the ring to move the entire object.

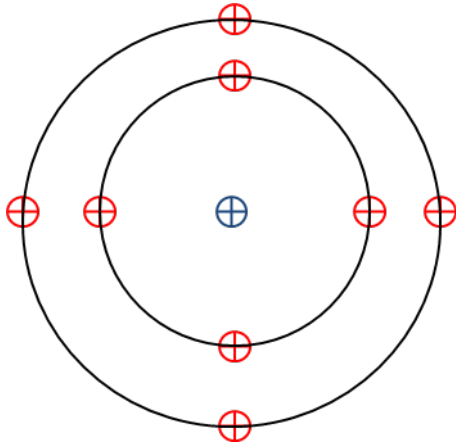

2) Drag the bottom vertex of the inner ring to adjust the inner ring radius.

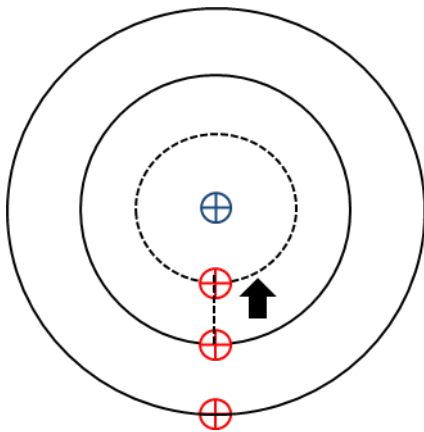

3) Drag the bottom vertex of the outer ring to adjust the outer ring radius.

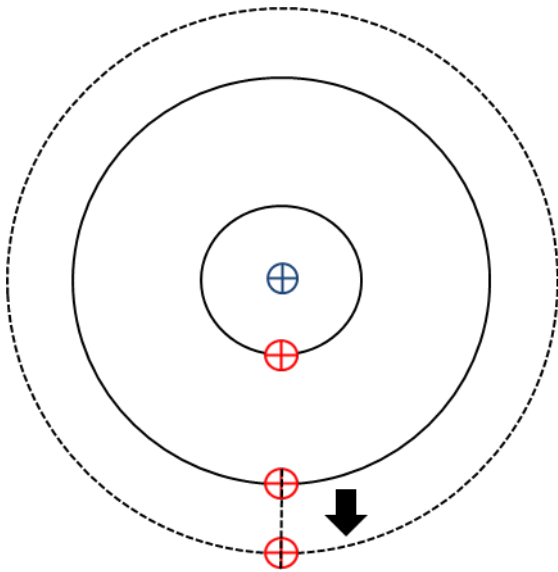

4) Finally, click the central crosshair or click the  button to complete setting the coordinate positions of the ring.

5) You can use steps 1–4 in coordination with the data in the right column to adjust the numerical values for the ring. See the picture below.

Ring		
Center	900	912
Inner Radius	162	
Outer Radius	598	

Remark Click  to restore the initial configured value.

4.3.6 Draw an Arc

Follow the steps below to draw an arc.

1) The initial state of the arc shows the central crosshair, inner arc circumference vertex, outer arc circumference vertex, and the two centroids of the lines connecting the inner and outer arc. Drag the crosshair at the center of the ring to move the entire object.

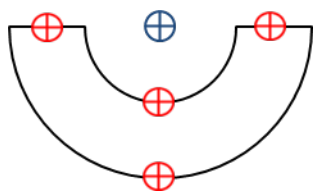

2) Drag the bottom circumference vertex of the inner ring to adjust the inner ring radius.

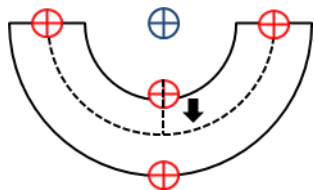

3) Drag the bottom circumference vertex of the outer ring to adjust the outer ring radius.

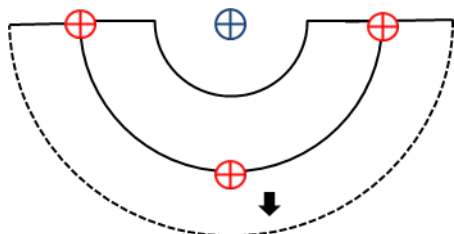

4) Drag one of the two centroids of the lines connecting the inner and outer arc to adjust the arc angle.

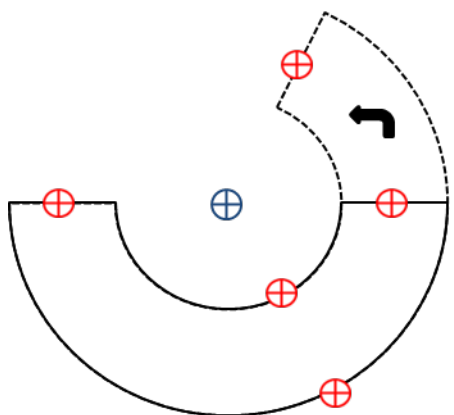

5) Finally, click the central crosshair or click the  button to complete setting the coordinate positions of the arc.

6) You can use steps 1–5 in coordination with the data in the right column to adjust the numerical values for the arc. See the picture below.

Arc	
Center	1024 912
Inner Radius	282
Outer Radius	593
Start Angle	294
End Angle	180

Remark Click  to restore the initial configured value.

4.3.7 Draw a Rotated Rectangle

Follow the steps below to draw a rotated rectangle.

- 1) The initial state of the rotated rectangle shows the central crosshair, the small square in the rectangle, and the straight line and the bottom and left vertices corresponding to the position of the small square. Drag the crosshair at the center of the rectangle to move the entire object.

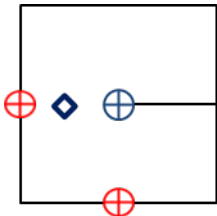

- 2) Drag one vertex to adjust the width of the rectangle in the corresponding direction

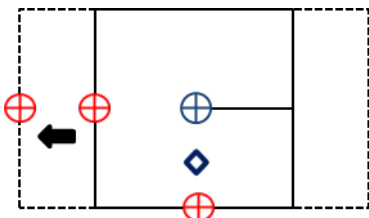

3) Drag the other vertex to adjust the width of the rectangle in the other corresponding direction

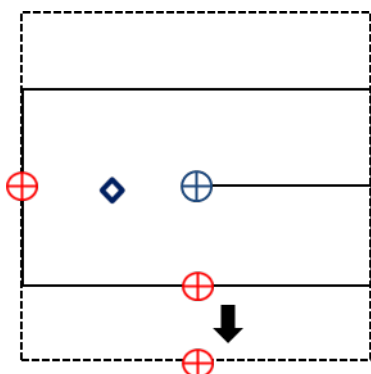



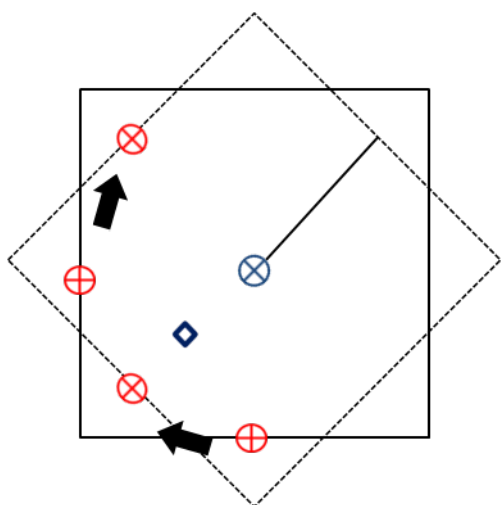











4) Drag the small square inside the square to rotate the angle of the rectangle.



5) Finally, click the central crosshair or click the  button to complete setting the coordinate positions of the rectangle.

6) You can use steps 1–5 in coordination with the data in the right column to adjust the numerical values. See the picture below.

Rotated Rect			
Center	1024	 	912  
Horizontal Axis	597  		
Vertical Axis	655  		
Angle	321  		

 **Remark** Click  to restore the initial configured value.

4.4 Add Inspections and Overview of Functions

Depending on the number of connected cameras, the DMV2000 can execute up to eight parallel processes. A single process can include a maximum of 1000 inspections that you can add, delete, copy, rename, and switch.

4.4.1 Inspections

When creating an inspection process, click **Add** to add a new inspection. In the **Add Unit** dialog box, you configure the **Inspection** function using visual inspection tools. Visual inspection tools can be categorized as counting numbers, detecting stains, locating coordinates, and measuring dimensions. The DMV2000 provides diversified inspection tools to satisfy different application needs. When you run the inspection application, stable and complete visual inspections usually require simultaneous judgment with several inspection tools to complete the process.

For example, when measuring the dimensions of moving objects, you must configure the coordinates for locating tools, such as Edge Position or Shape, to ensure stable and accurate measurements. This requires coordinated execution between the inspection and the locating functions.

You must first identify the characteristics and targets of the items to be detected before designing the visual inspection system, as the run length of each inspection may vary. Choosing the optimal method and combination not only improves system stability but also decrease inspection time and improves productivity. The following picture shows the available visual inspection tools.

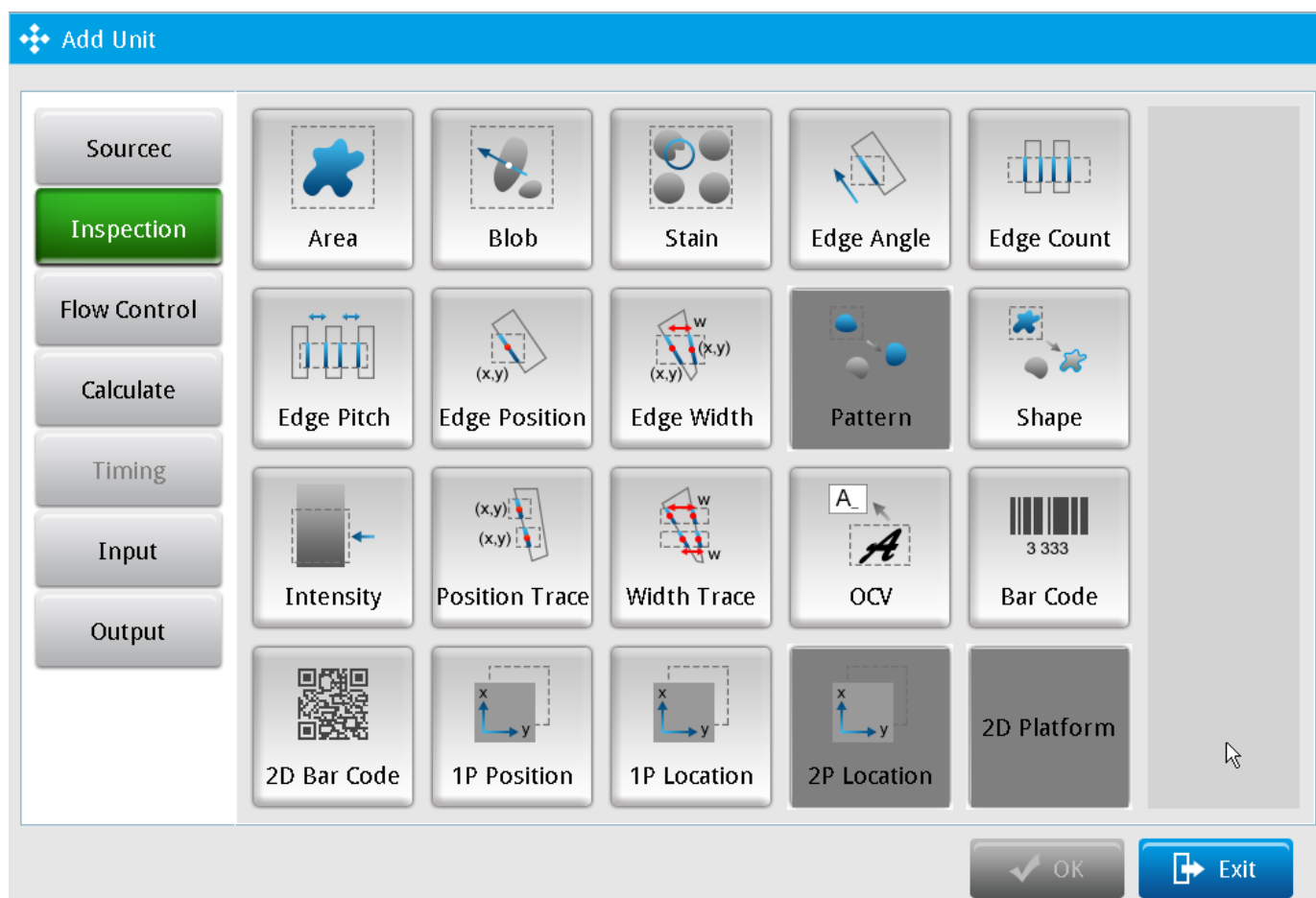

Area

The function calculates the number of black or white pixels in the predefined region. This function uses a binary method to convert the image to only black and white layers for measurements. When the numbers of black or white pixels is in the specified numeric range, the inspection result is OK; otherwise, when the number of pixels exceeds the configured range, the inspection result is NG.

Blob

This function uses a binary method to convert the image so that it consists of only black and white layers, and then calculates groups of black and white pixels. When the number of pixels is in the specified range, the group of pixels is defined as a blob. This method can detect the number, area, and coordinates of multiple blobs.

Stain

This function detects stains in a fixed direction, such as scrapes and smears on the object.

Edge Angle

This function finds the two edges formed by a brightness changes on a gray-scale image, then scans horizontally or vertically to find the coordinates of the two edges. It then draws a straight line, and finally calculates the angle of inclination of the straight line against the horizontal axis.

Edge Count

This function determines whether the image brightness variation agrees with the specified value. If the number of edges is in the specified range, the inspection result is OK; otherwise, when the number of detected edges is not in the specified range, the inspection result is NG.

Edge Pitch

This function is an enhanced version of Edge Width (below), and is capable of measuring multiple widths instead of just the width between two edges. The function calculates the individual width, maximum width, minimum width, and average width.

Edge Position

This function finds edges formed by brightness variations in a gray-scale image. It finds two edges through horizontal or vertical scanning. When the brightness variation agrees with the specified values and the function finds the X and Y axes, the inspection result is OK; otherwise, when the function fails to detect brightness variations that agree with the specified values, the inspection result is NG.

Edge Width

This function finds the edges formed by brightness variations in gray-scale images and calculates the edge widths by finding either the outer or inner edges through horizontal or vertical scanning. When the brightness variation is in the specified range, the inspection result is OK; otherwise, when the measured width is outside the specified range limit, the inspection result is NG.

Shape

This function finds the default sample image in the configured region and searches the profile (edge), X coordinate, Y coordinate, and rotation angle of the specific sample, and then compares it with the default sample. In general, it is recommended to use the shape tool first when the object to be inspected is offset, before providing the X and Y coordinates and rotation angles to subsequent inspection tools as reference for correcting offset.

Intensity

This function measures the maximum intensity, minimum intensity, average intensity, and standard deviation of intensity of all the gray-scale pixels in the inspection region.

Position Trace

This function enhances the Edge Position function, which can only find 2 edges. Position Trace searches for edge positions using brightness variations that agree with the measured widths through horizontal or vertical scanning. It can find multiple edge positions on the same surface and output the coordinates.

Width Trace

This function enhances the Edge Width function, and finds the distances between edges by searching for outer or inner edges through horizontal or vertical scanning. It can output the maximum and minimum distances measured. This function can measure the maximum, minimum, and average widths and check whether they agree with the configured range.

OCV

You establish a dictionary to determine whether the input strings in the region of inspection agree with the specified threshold. When the scanned input string agrees with the specified value, the inspection result is OK; otherwise, when the scanned input string disagrees with the specified value, the inspection result is NG. The DMV2000 currently supports upper and lower case English characters (A–Z), numbers 0–9, and symbols.

Bar Code

This function reads 1D bar codes by searching for a valid 1D bar code in the ROI (region of interest). Once detected, the function decodes the bar code and outputs the result. When the scanned bar code agrees with the specified value, the inspection result is OK; otherwise, when the scanned bar code disagrees with the specified value, the inspection result is NG.

2D Bar Code

This function reads 2D bar codes by searching for a valid 2D bar code in the ROI. Once the function detects the bar code, the function decodes the bar code and outputs the result. When the scanned bar code agrees with the specified value, the inspection result is OK; otherwise, when the scanned bar code disagrees with the specified value, the inspection result is NG.

1P Position

Creates the coordinate conversion matrix (CCM) is configured to convert between the visual and mechanical coordinate systems. The coordinate units of machine visual inspection uses pixels, while device (such as mechanical arms) use actual physical units (i.e., mm).

1P Location

Creates the coordinate conversion matrix (CCM) is configured to convert between the visual and mechanical coordinate systems. The coordinate units of machine visual inspection uses pixels, while device (such as mechanical arms) use actual physical units (i.e., mm). This function then calculates the offset for positioning.

4.4.2 Calculate, Input, and Output

When creating an inspection process, click **Add** to add new calculations and configure the input and output for the inspection. In the **Add Unit** dialog box, you configure the **Calculate**, **Input**, and **Output** functions.

⊙ Calculate

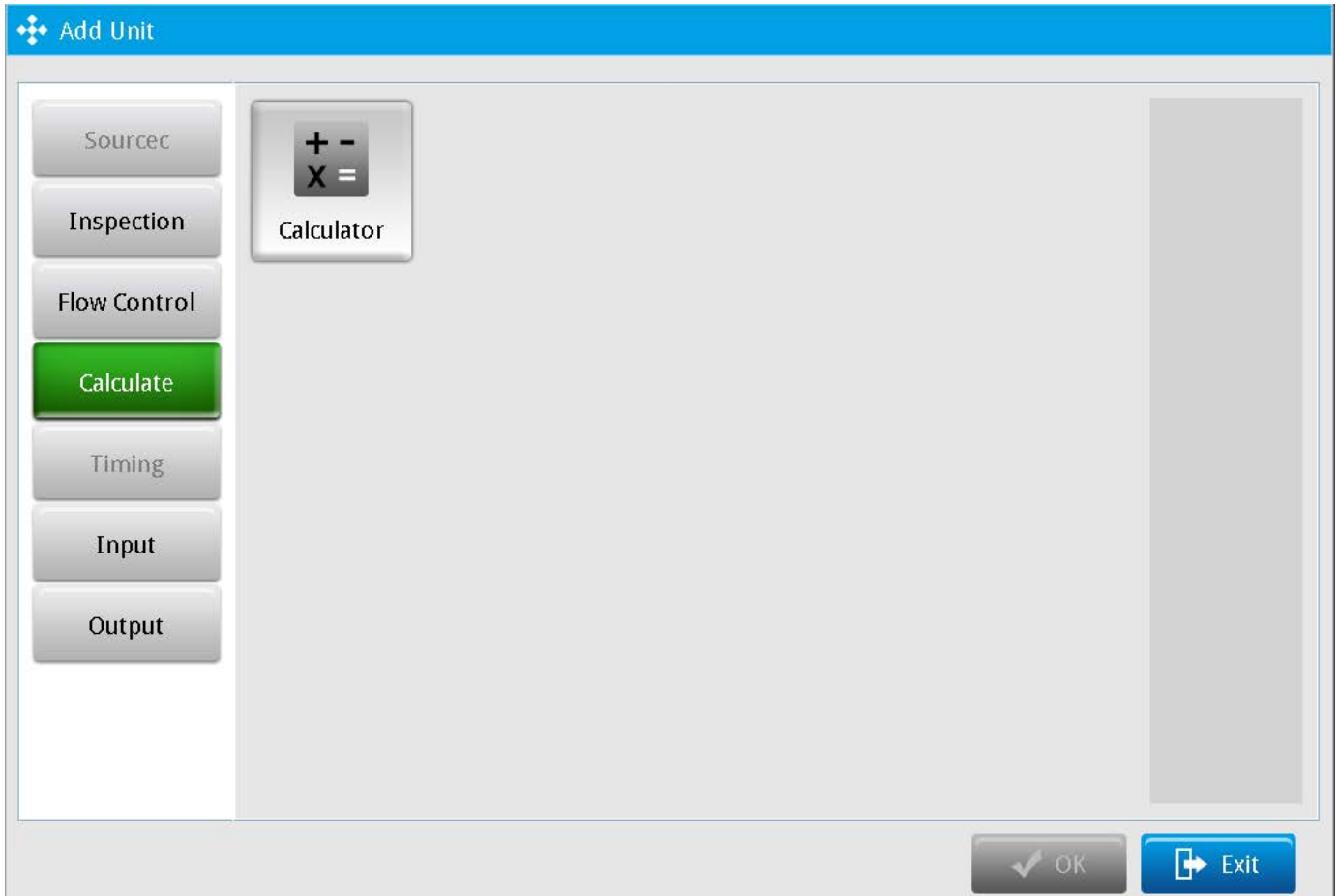

Calculate applies arithmetic operations and function calculations on data from **Inspections** after completing the inspection process to obtain new data. You can use the new data in the subsequent **Output** function. In addition, you can use upper and lower limits in the calculator to set the calculator-specific logic flag, and pass this result to the subsequent **Judge** and **Output** programs.

Input

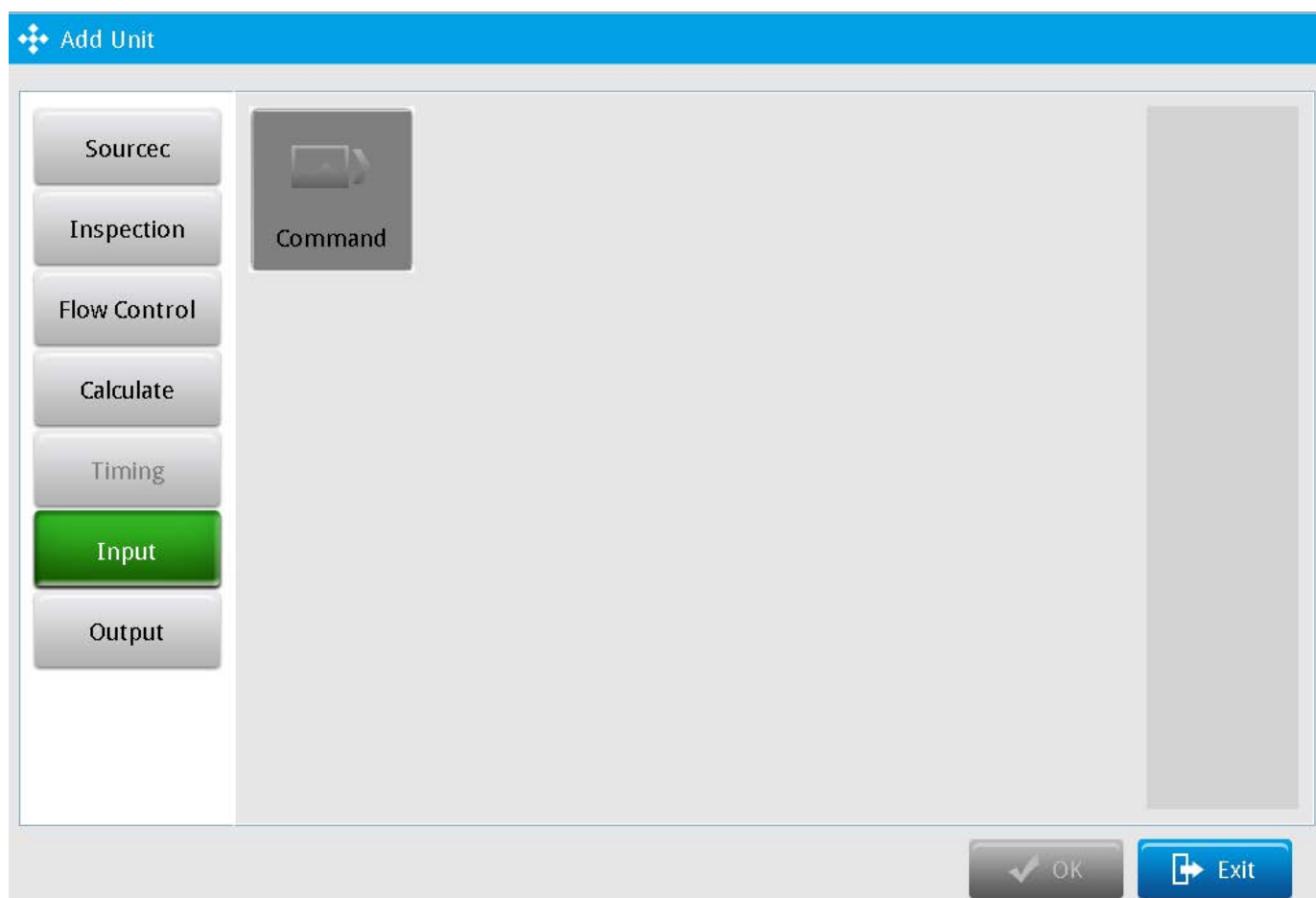

Input is the signal controlling process inspections, which you can split through **Command Input** to configure multiple inspection objects in a single flow process. This allows the system to execute multiple inspections without connecting to multiple cameras.

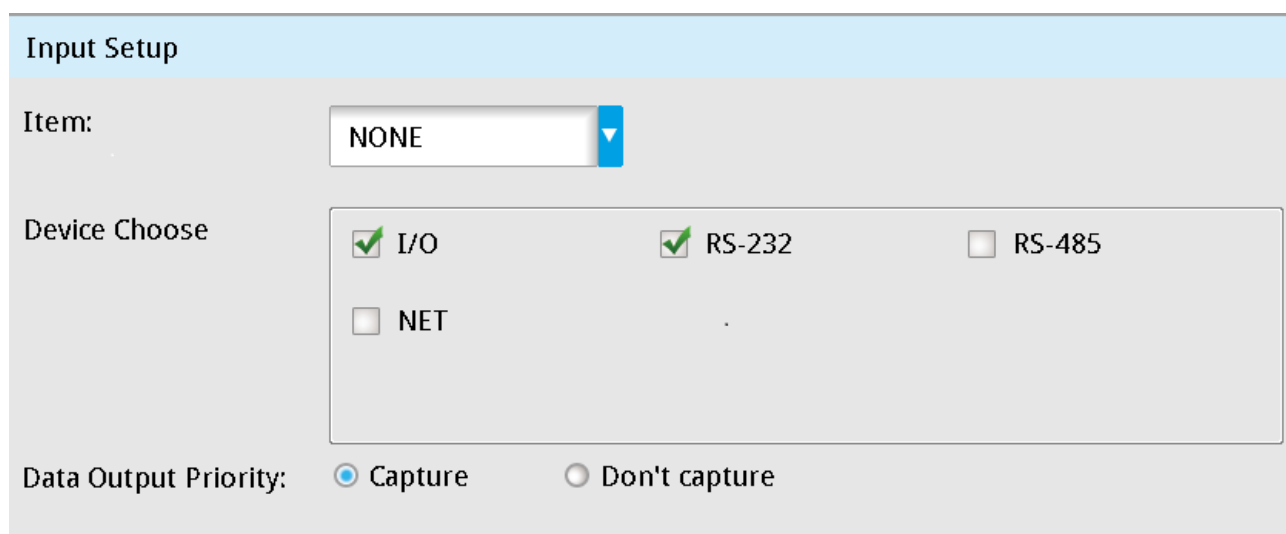

Item

Specifies the INPUT signal sources in coordination with **External Terminal** from the **Device Setting** in **System Setting** (NONE or WTR1–WTR8).

➤ **Device Choose**

Specifies the signal sources (I/O, RS232, RS485, or NET communication interfaces).

➤ **Data Output Priority**

Specifies whether to recapture the image when the flow process receives the continue inspection signal.

⊙ **Output**

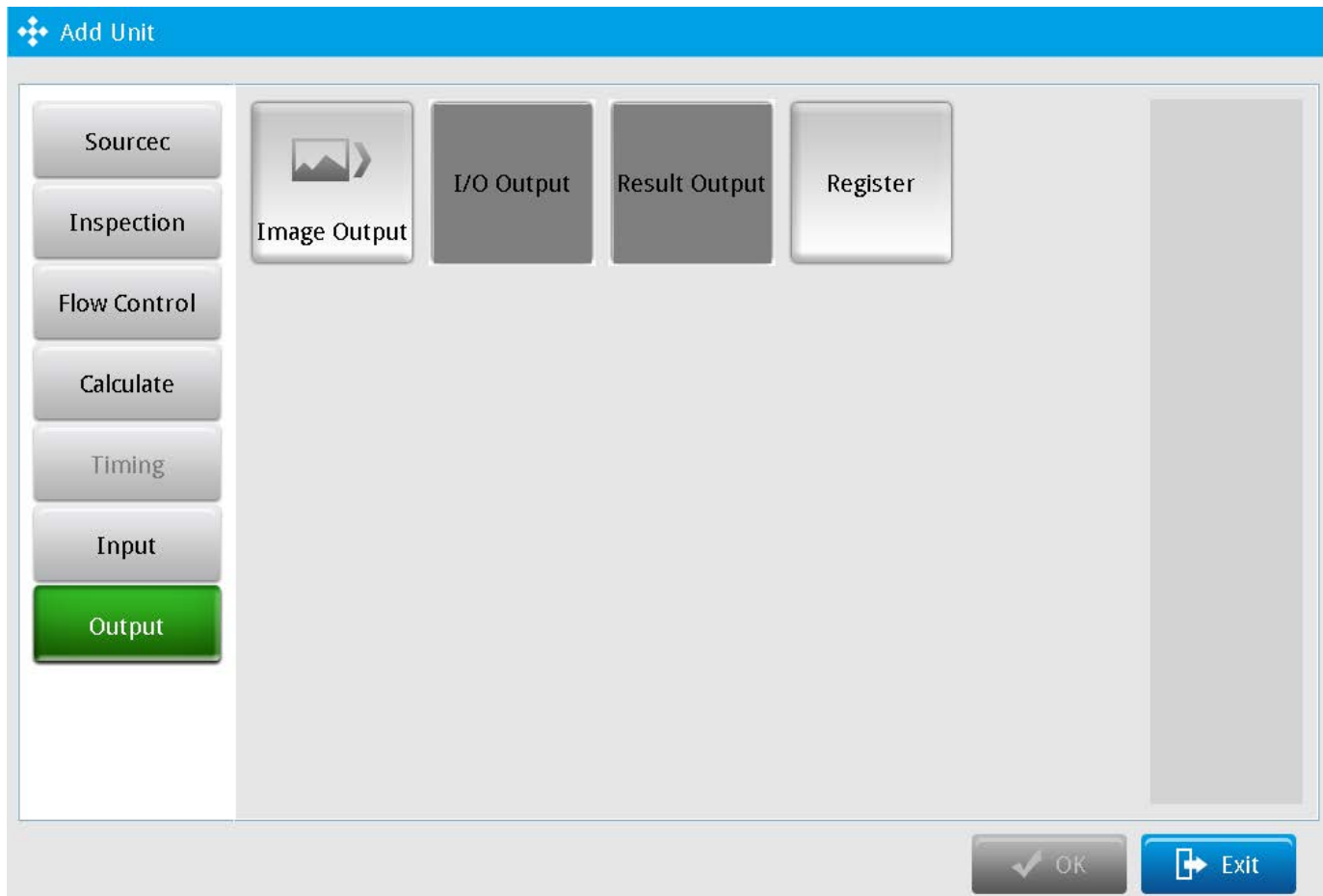

You can choose to output the numeric data from **Inspection** and **Calculate** and the logic flag from **Inspection** and **Calculate** through any communication interface (for example, RS232, RS485, I/O, and Ethernet).

► Image Output

Select the hardware interface (Ethernet, SD card) as the output for the results. Next, click **Detail Setup** and select the desired inspection output (OK/NG) screen during project execution. The following picture shows the **Image Output** dialog box.

Image Output

Item: When NG Output ▼

Condition: **Detail Setup**

Device Choose

Ethernet FTP SD Card

SD Card 2

Data Output Priority: Process First Output First

When No Storage: Stop Process Ignore Output

Folder: Split for file number Split for file date

File number in folder: 100

Saved Image Format: BMP Format ▼

◆ Item

Specifies whether to output the image when OK or NG

◆ Condition

Specifies the inspection to output the image.

◆ Device Choose

Specifies the communication output interface for the output.

◆ Data Output Priority

Specifies the image output priority: Process First or Output First.

When you select either the **RS232** or **RS485** check box:

- **Process First:** After the inspection is complete but before the output to the SD card is finished, the RS232, RS485, Ethernet, SD card, and external terminal cannot output when the TRIG triggers the inspection signal input.
- **Output First:** After the inspection is complete but before the output to the SD card is finished, the trigger reception is disabled (the TRIG triggers inspection signal input) until the output to the SD card is complete.

◆ When No Storage

Specifies the action when running out of memory for image output: Stop Process or Ignore Output.

1) When you select either the **RS232** or **RS485** check box:

- **Stop Process:** When data is being output to the SD card and the output register space is insufficient, a warning appears and all subsequent trigger and inspection processes stops.
- **Ignore Output:** When data is being output to the SD card and the output register space is insufficient, the system continues the inspection processes but does not output the inspection results.

2) When you select the **SD Card** check box:

- **Stop Process:** When data is being output to the SD card and the output register space is insufficient, a warning appears and all subsequent trigger and inspection processes stops.
- **Ignore Output:** When data is being output to the SD card and the output register space is insufficient, the system continues the inspection processes but does not output the inspection results.

◆ Folder

Selects the storage method: **Split for File Number** or **Split for File Date**.

◆ Number of Folders

Configured Value: 0–99999999

◆ Saved Image Format

Selects the image format: always saves in BMP format

► Register

The DMV2000 provides 32 internal registers. You can select Constant, Judge Value, and Inspection Result Value, and load these specified values in the Calculate tool.

◆ Constant

Specifies a fixed value.

◆ Judge Value

Specifies the item (inspection) Judge value: inspection result OK = 1 and NG = 0.

◆ Inspection Result

Specifies the inspection result for numerical values.

The image shows a software interface titled "Register Setting". It contains a list of 12 registers (Reg 1 to Reg 12). Each register has a dropdown menu currently set to "None", a "Value =" field with "0.000", and a "Select" button. A "Setup" dialog box is overlaid on the interface, featuring three buttons: "Constant Value" (highlighted in blue), "Judgement Value", and "Inspection Result Value". An "Exit" button with a right-pointing arrow is located at the bottom right of the Setup dialog. A vertical scrollbar is visible on the right side of the Register Setting window.

4.5 Result Output and Status Item

After completing the flow inspection configurations according to your inspection requirements, you must configure the Judge Settings for use during Run mode. Result Output and Status Item are required items when you configure Judge settings. You must select the inspection result value (OK/NG) in the Result Output configuration dialog box and then configure Status Item to display the inspection results (OK/NG).

Remark Judge is the basis for the inspection results. Please refer to Chapter 7 for the detailed setup information.

4.5.1 Result Output

You can configure the content of each inspection result (including each numerical and logical result from Inspection, Calculator, and Judge) to output to the superior PC or PLC through Result Output. The system provides various communication interfaces, such as External I/O Terminal, RS232, RS485, Ethernet, and SD Card. You can choose the communication interfaces to communicate with the superior controller.

- During the inspection process, click the **Result Output** box to display the **Output Function Edit** dialog box.

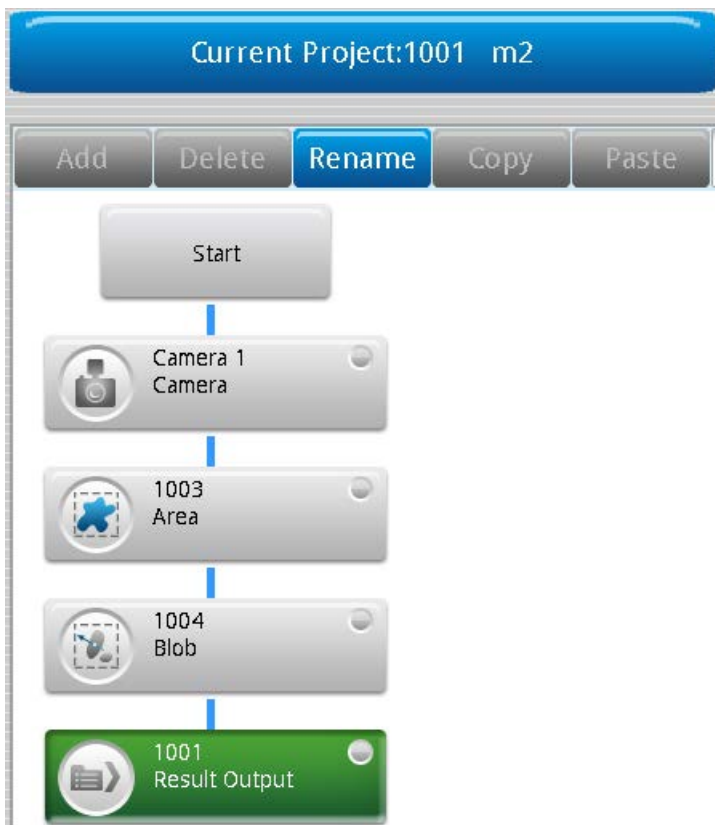

- Click **Detail Setup** to display the **Result Output** dialog box.

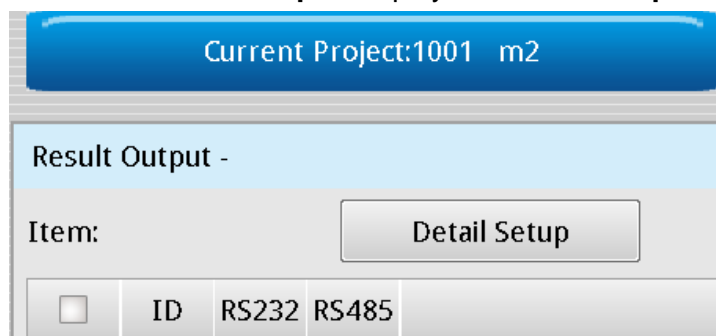

- Select the inspection result to output. Note that the item names match the names of the Inspection boxes in the inspection process.

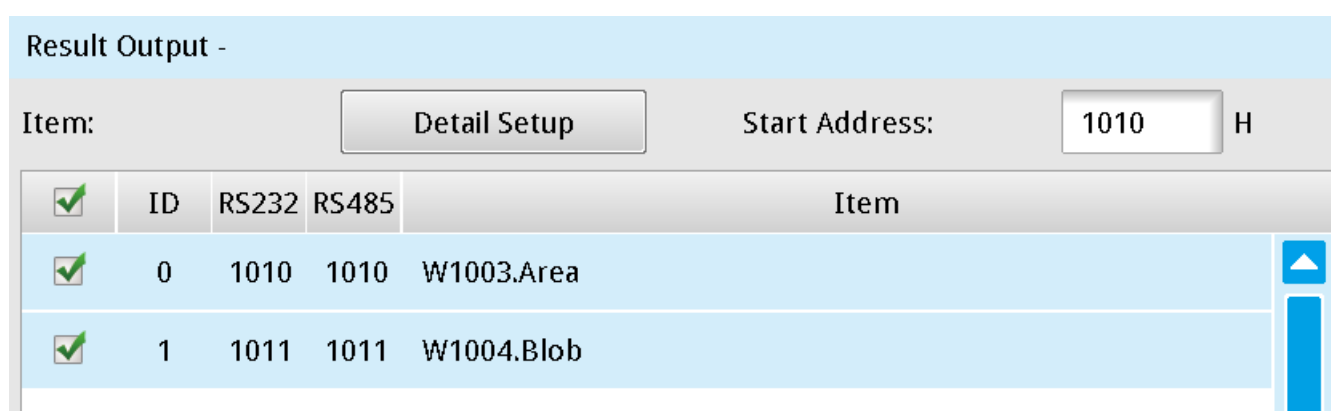

- Configure **Device Choose**, **Data Output Priority**, and **When No Storage**.

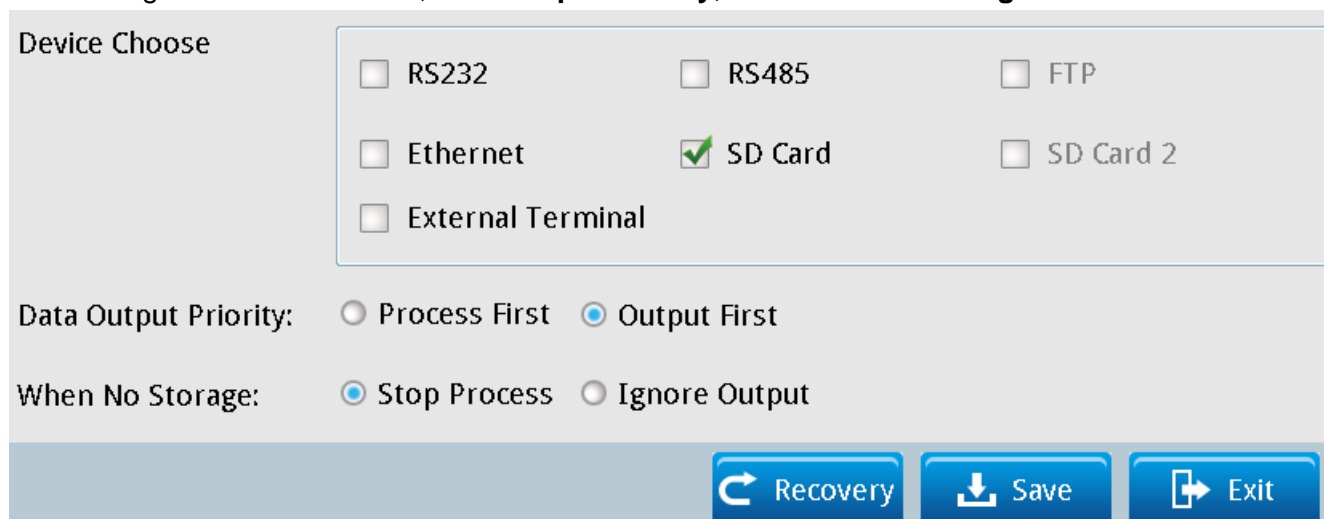

◆ Device Choose

Specifies the communication interface to output the contents: **RS232**, **RS485**, **Ethernet**, **SD Card**, and **External Terminal**. **FTP** and **SD Card 2** are currently not supported.

◆ Data Output Priority

When you select the **RS232** or **RS485** check box:

- **Process First:** After the inspection is complete but before the output to the SD card is finished, RS232, RS485, Ethernet, SD card, and external terminal cannot output when the TRIG triggers the inspection signal input.
- **Output First:** After the inspection is complete but before the output to the SD card is finished, the trigger reception is disabled (the TRIG triggers inspection signal input) until the output to the SD card is complete.

◆ When No Storage

1) When you select the **RS232** or **RS485** check box:

- **Stop Process:** When data is being output to SD card and the output register space is insufficient, a warning appears and all subsequent trigger and inspection processes stop.
- **Ignore Output:** When data is being output to the SD card and the output register space is insufficient, the system continues the inspection processes but does not output the inspection results.

2) When you select the **SD Card** check box:

- **Stop Process:** When data is being output to the SD card and the output register space is insufficient, a warning appears and all subsequent trigger and inspection processes stop.
- **Ignore Output:** When data is being output to the SD card and the output register space is insufficient, the system continues the inspection processes but does not output the inspection results.

◆ Restore

Restores the initial settings

◆ Save

Saves all modified parameters and values

◆ Exit

Leaves the dialog box.



Reference

Please refer to Section 6.3 for the detailed setup for result output

4.5.2 Status Item

The Status Item allows the on-site operators to see the logical (OK/NG) and numerical inspection results. It is provided in Run mode, and you can choose the specific data to display in the Status Table.

Click **Detail Setup**, and then select the inspection to be judged (OK/NG) in Run mode.

- ▶ During the inspection process, click the **Status Item** box to display the **Result Signal Edit** dialog box.

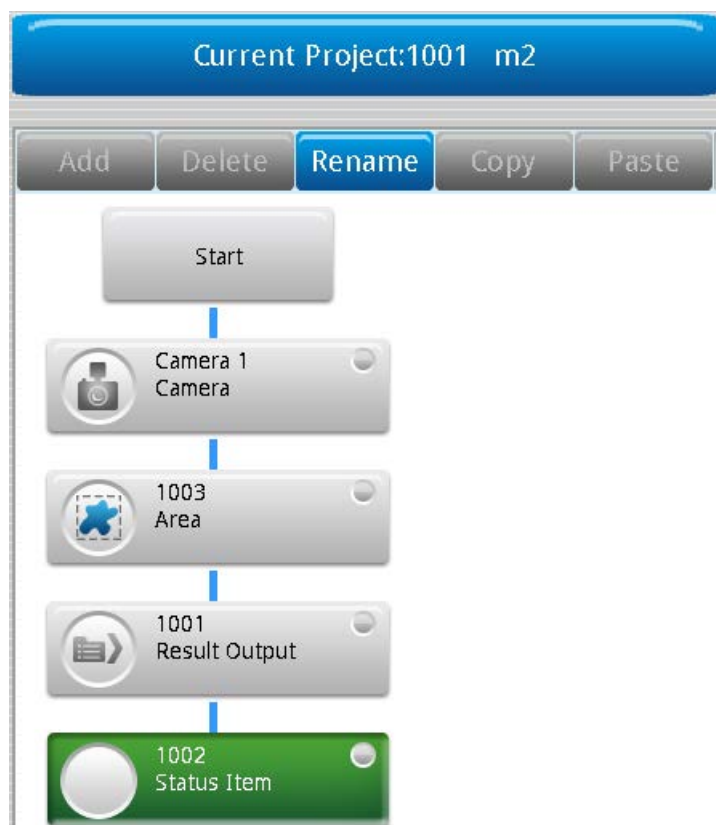

➤ Click **Detail Setup** to display the following dialog box.

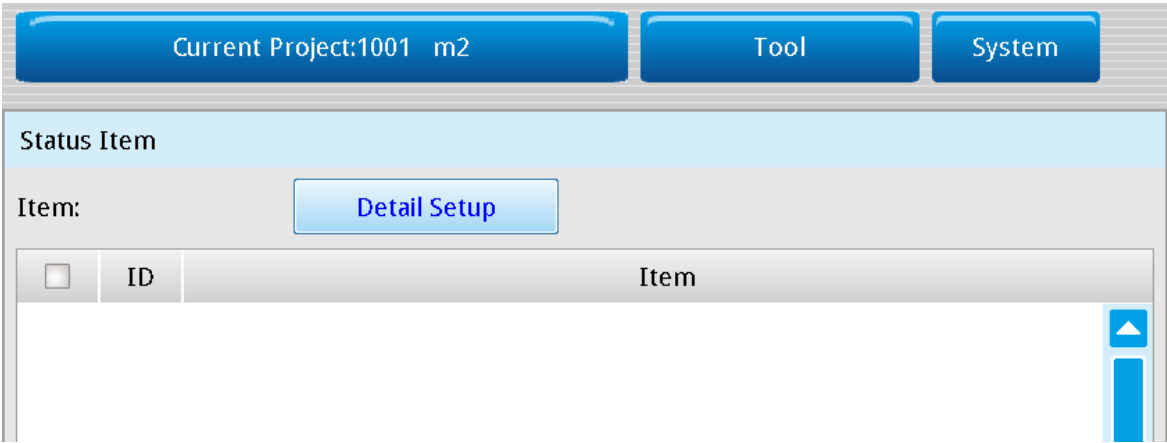

➤ Select the inspection where you want to add a judge result (OK/NG) in Run mode.

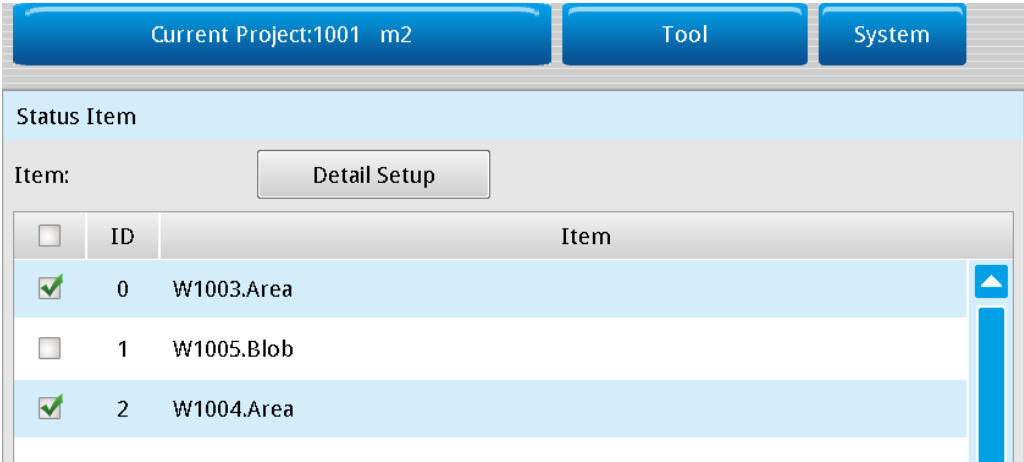

- After completing the configuration and switching to Run mode, the **Image Display Window** appears on the left side of the screen. Select the **LED menu** check box at the bottom (as shown in the lower left diagram) to display the **Item** LED data table with the user defined result items (as shown in the lower right diagram).

Image Display Window

Window

Window 1 ▾

Window 1 ▾

Window 1 ▾

Window 1 ▾

Image Type

Original

Characteristic

Filtered(All)

37%

< >

Result

Item	Value
Total Area	521578.000

< >

Display Setting

LED menu Statistics

Image Display

Item

OK	Item	Lower	Value	Upper
+	W1003.Area	---	1.000	---
+	W1004.Area	---	1.000	---
○	None	---	---	---
○	None	---	---	---
○	None	---	---	---

Page: / < >

4.6 Run Mode

After you configure Camera, Inspection, Result Output, and Status Item for each project, then on the Main window, click **Run** in the lower right corner to display the Run Mode window. All configured trigger conditions must be met to begin execution. The system then executes the configured inspections in the image inspection project. Finally, the system gets and displays the actual logical results and status on the Run Mode window.

To edit the Run Mode window and the display of logical output and status, from the **Tool** menu click **Judge Setting** to configure the logical basis for the individual inspection results. Click **Screen Editing** to configure the display on the Run Mode window.



The following picture shows the Run Mode window including the controller display during Run mode.

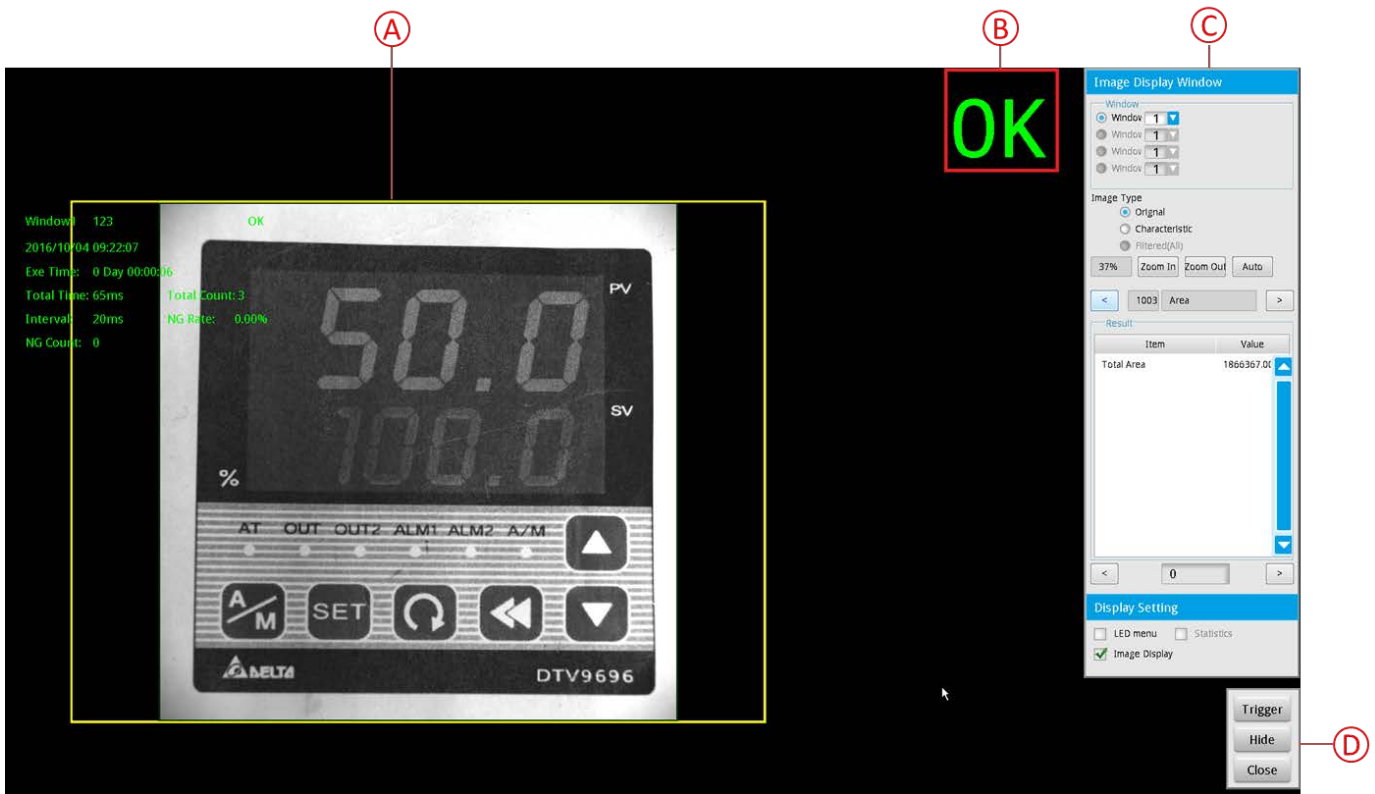

A. Inspection Result Display Window

This is the Inspection Result Display window that displays the inspection objects from the instant camera captures. Regardless of the number of parallel processes in the project, the display can show a maximum of four inspection windows at a time.

- The inspection window displays the inspection progress with ten text items.



- 1) Name of window (Window 1–Window 4)
- 2) Date and time of inspection
- 3) Duration of currently executing inspection
- 4) Total time of inspection
- 5) Interval between each inspection trigger
- 6) Number of NG inspections

- 7) Logical result (OK/NG) of the inspection in the window
- 8) Total number of inspections
- 9) Ratio of NG inspections
- 10) Name of the inspection project

B. Inspection results from all windows included for judgment

This is the result according to the Judge Settings you configured (from the **Tools** menu). For example, suppose you set the display for four windows in the project and Window 1–Window 3 are OK while Window 4 is NG. If you set Window 4 in Judge Setting to be one of the final logical results, the inspection result displayed is NG.

C. Image Display Window

➤ Window

The Run Mode window can simultaneously display inspection processes in Window 1–Window 4. The corresponding process numbers for each window appear in the panel.



➤ Image Type

You can select the display method for the captured images from the cameras: Original, Characteristic, and Filtered (All). These options are described below using the Stain inspection tool as an example.

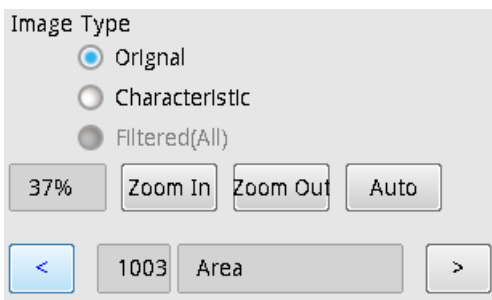

1) **Original:** the original image captured by the camera.

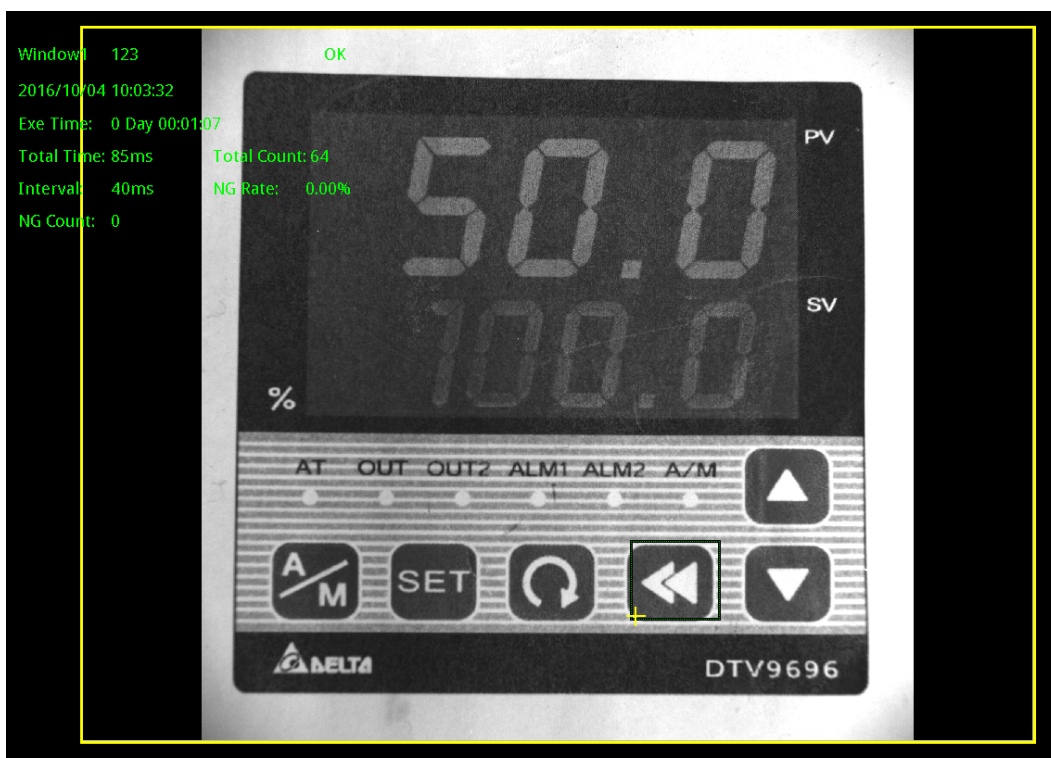

2) **Characteristic:** this function is only applicable for the inspection tools Area, Blob, Stain, Shape, Edge Width, Edge Pitch, Edge Count, and Position Trace. The purpose of this function is to display more information in the ROI (region of interest) part of the image.



3) **Filter (All):** The ROI image is displayed after Preprocessing.



◆ You can adjust the size of the captured image by clicking Zoom In, Zoom Out, and Auto. The current image size in percentage is displayed on the left.

1) **Zoom In:** enlarges the image captured by the camera.



2) **Zoom Out:** reduces the image captured by the camera.

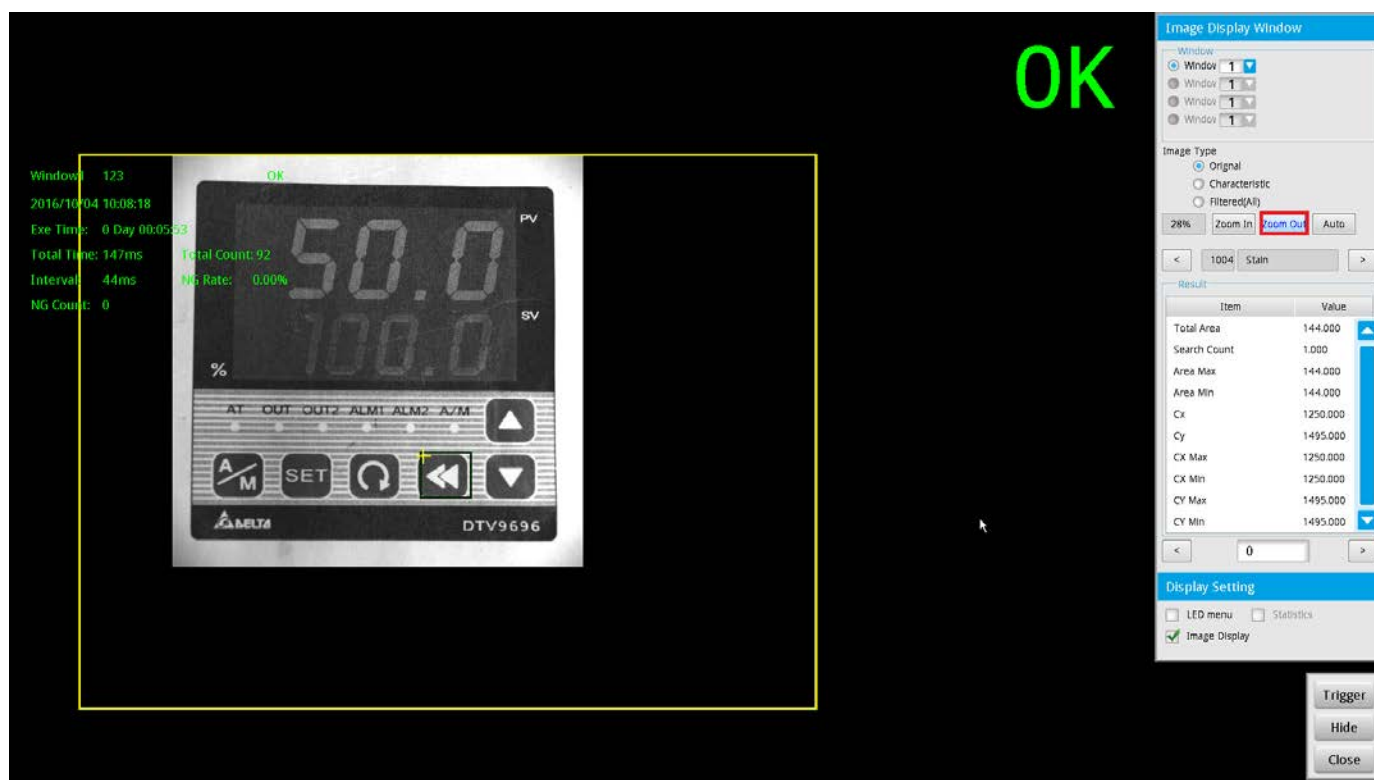

3) **Auto:** automatically displays the most suitable image display ratio.



◆ You can change the displayed inspection by clicking the left and right arrow buttons ([<], [>]) above the Result table. The ID and name of the inspection is displayed between the arrow buttons.

➤ **Result**

- ◆ An inspection process can include multiple inspections, and you can use the left and right arrow buttons display the result values for each inspection. These results include each item and the numerical values from the inspection.
- ◆ You change the coordinates for the view of the inspection by clicking the left and right arrow buttons ([<], [>]) below the Result table. The coordinate number of the inspection is displayed at the center between the arrow buttons.

The following picture shows an example for the Stain inspection tool.

Item	Value
Total Area	144.000
Search Count	1.000
Area Max	144.000
Area Min	144.000
Cx	1250.000
Cy	1495.000
CX Max	1250.000
CX Min	1250.000
CY Max	1495.000
CY Min	1495.000

< 0 >

Reference Please refer to Chapter 5 for the numeric output results for each inspection.

➤ **Display settings**

- ◆ **LED menu:** select this check box to display the **Item** table that shows the results for inspections. You must first configure the status items you want to display before they appear in the table.

OK	Item	Lower	Value	Upper
<input checked="" type="checkbox"/>	W1003.Area	---	1.000	---
<input checked="" type="checkbox"/>	W1004.Area	---	1.000	---
<input type="checkbox"/>	None	---	---	---
<input type="checkbox"/>	None	---	---	---
<input type="checkbox"/>	None	---	---	---

Page: 1 / 26 < >

Reference Please refer to Section 6.4 for the detailed setup information for status items.

- ◆ **Image Display:** select this check box to continuously update the display with new images from the camera; otherwise, the image screen does not update.

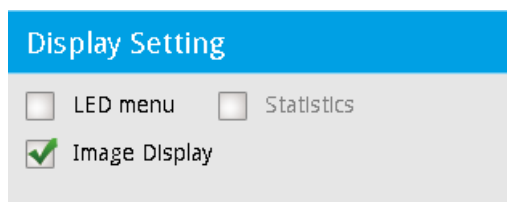

D. Trigger, Hide, Close

These buttons are the operation controls for the inspection screen.

- ◆ **Trigger:** When you do not specify **Internal Trigger** in **Trigger Setup** for auto trigger, then you must click **Trigger** to trigger the flow inspections.
- ◆ **Hide:** close the Image Display window, leaving only the inspection window on the screen.
- ◆ **Close:** exit Run mode and return to Edit mode (Main window).

Chapter 5

Inspection

5.1 Area

This image inspection tool uses a binary method to convert the image to black and white, and then count the number of black and white pixels in the area.

⦿ **Algorithmic Processing**

The Area tool uses a binary method to convert images to black and white before counting the black or white pixels.

⦿ **Procedural Results**

Area returns the following inspection results.

- Area: outputs the number of black and white pixels.

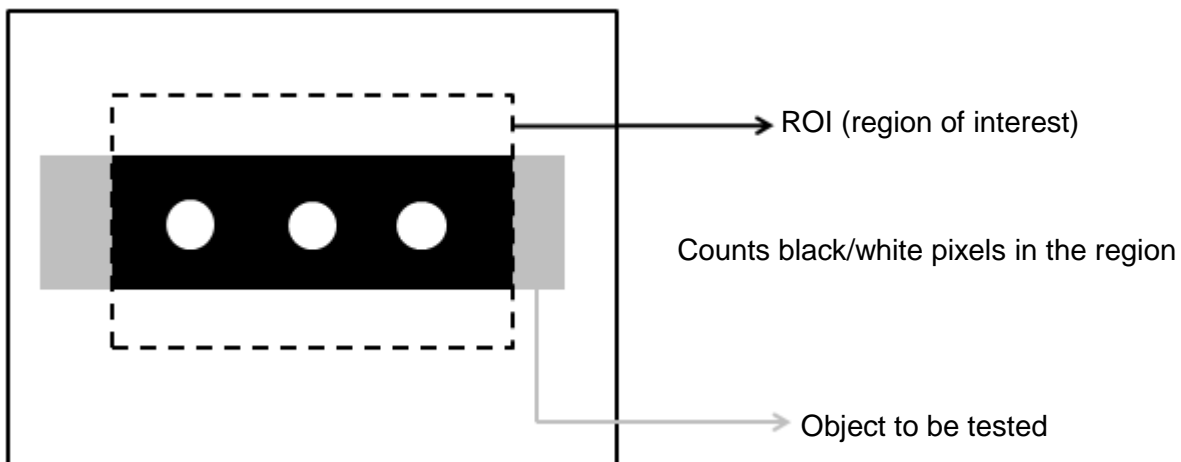

⦿ **Example**

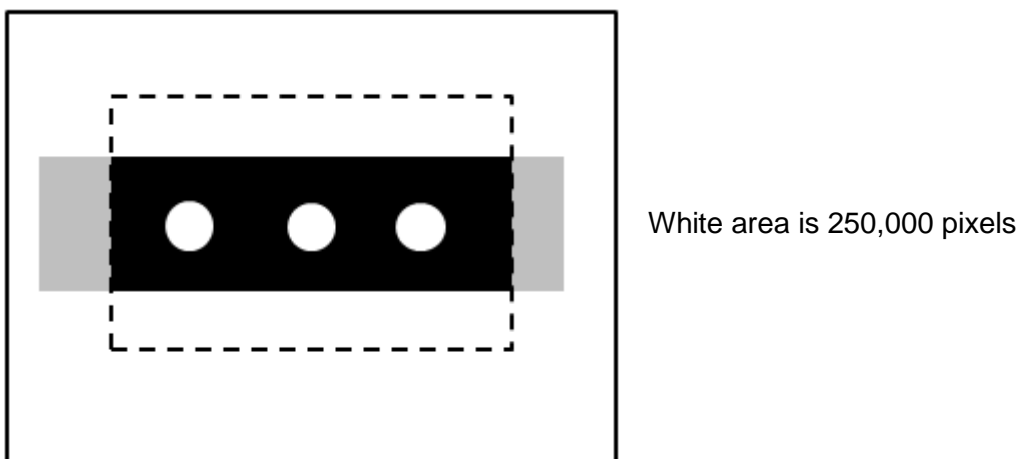

© Area dialog box

The following picture shows the Area inspection tool dialog box.

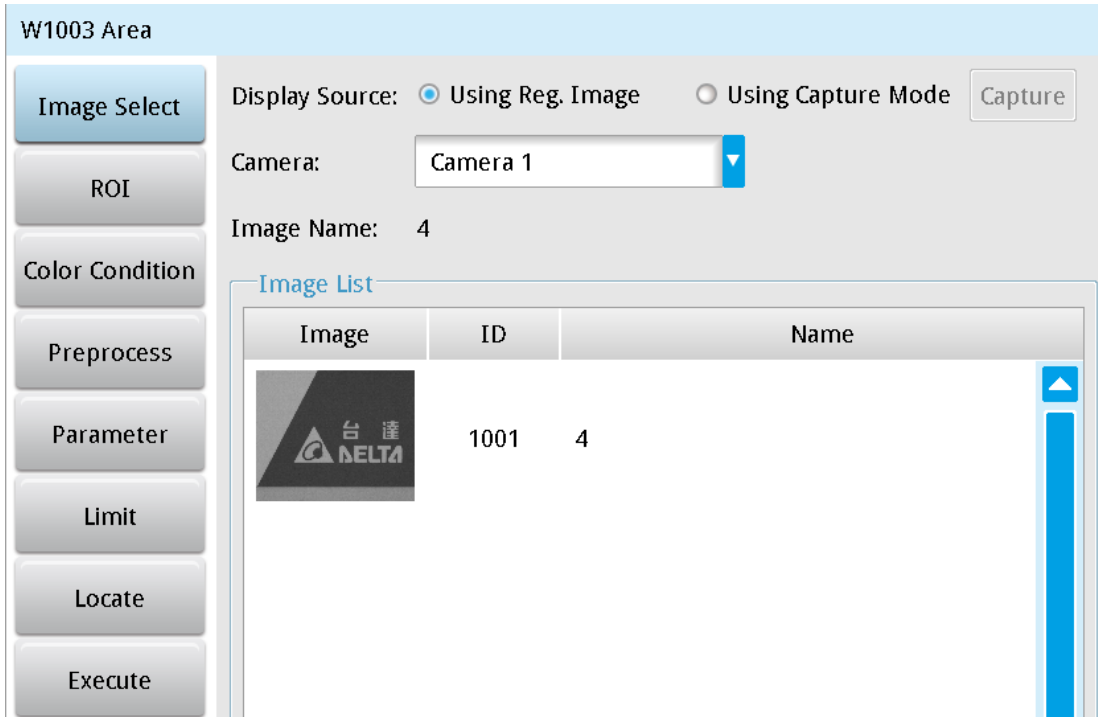

► Image Select (select Register Image)

Selects the image to be inspected from the register gallery. You can configure source cameras and inspect the image display source. When you select a different camera, the image table also switches to show the registered images acquired from that camera.

► ROI (configure detection region of interest)

Specifies the inspection regions to be used in the inspection. Optional ROI shapes include Rectangle, Circle, Arc, Ellipse, Ring, Polygon, and Rotated Rect. The Polygon ROI supports up to 16 points. In addition, there are up to eight mask functions to ignore particular segments.

► Color Condition

Selects the color processing for images from a color camera: Color to Binary, Color to Grayscale, RGB grayscale, R Grayscale, G Grayscale, and B Grayscale.

► Preprocess

Specifies the image processing to apply before inspections to enhance certain aspects of the image. Preprocessing methods include Binary, Dilation, Erosion, Average, Median, Laplacian, Sobel X, Sobel Y, Sobel XY, Brightness, Contrast, Shade, and Custom (filter). You can superimpose up to six methods or create a custom method by clicking **Custom**.

► Parameter

Adjusts the Area inspection conditions.

Binary Limit

This function configures the upper and lower limits of the binary method that converts pixels in the configured range to white pixels, and converts the remaining pixels to black pixels. As shown in the following diagram, when you set the lower limit to 60 and the upper limit to 200, all gray scale values between 60 and 200 are converted to white, and the remaining pixels are converted to black.

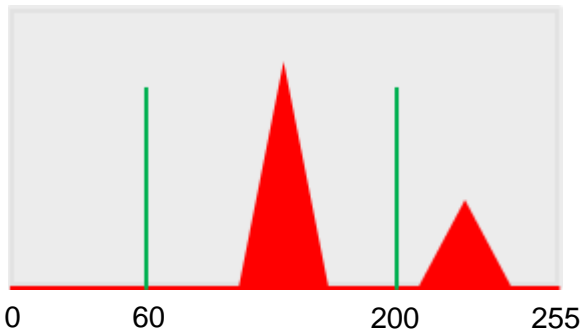

Object

Specifies whether to count pixels in the area of white or black objects.

➤ Limit

Specifies the upper and lower limits for inspection results to determine whether the result is qualified.

Area: specifies the upper and lower limits for Area.

➤ Locate

Specifies whether the inspection region follows an inspection result by adjusting its coordinates (X, Y) and Angles (Theta). The inspection tools you can use as a reference includes Shape, Blob, Edge Position and Edge Angle. As shown in the following diagram, specific marks (such as the cross on the object) can be used for the Locate function.

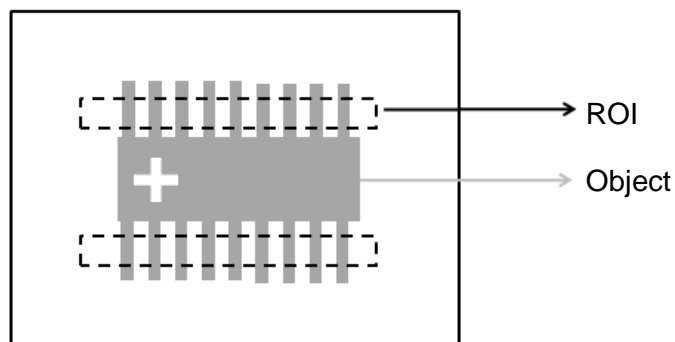

Locate Off

Locate On

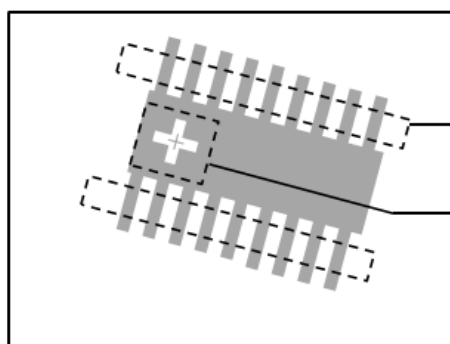
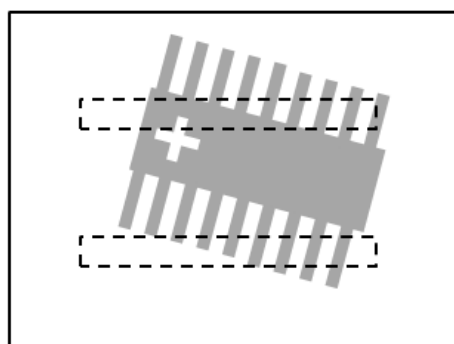

➤ Three tools are also provided in this item for quick configuration.

Tool

Ref. Previous Unit

Ref. Available Unit

Ref. Unit

Ref. X :

None

Select

CLEAR

Ref. Y :

None

Select

CLEAR

Ref. Angle :

None

Select

CLEAR

◆ **Reference Previous Unit**

Selects the nearest inspection tool that can provide reference for Locate, and automatically fills in the **Ref. X**, **Ref. Y**, and **Ref. Angle** fields.

◆ **Reference Available Unit**

Selects the nearest unit with Locate configured, and automatically fills in the **Ref. X**, **Ref. Y**, and **Ref. Angle** fields.

◆ Reference Unit

Arbitrarily selects an inspection tool that can provide locating reference, and automatically fills in the **Ref. X**, **Ref. Y**, and **Ref. Angle** fields.

 **Reference** Please refer to Section 9.1 for detailed Locate configurations.

⊙ Execute

Specifies whether to execute the inspection function in the inspection process.

➤ Always Execute

Always execute the inspection function in Run mode.

➤ Never Execute

Never execute the inspection function in Run mode.

⊙ Save

Saves all modified parameters and values.

⊙ Exit

Leaves the dialog box.

⊙ Output Item**➤ Window**

Selects the output window for the total Judge result for the Area tool on the designated interface.

➤ Item

- 1) **Area**: outputs the pixel count from the Area tool.
- 2) **Area ID**: outputs the ID of the inspection tool.
- 3) **Total Area (J)**: outputs the logical (Judge) result of the pixel count obtained by the Area tool.

5.2 Blob

This image inspection tool uses a binary method to convert the image to black and white and then count the number and area of contiguous black or white pixel groups, and then calculates the coordinates of each contiguous pixel group.

© **Algorithmic Processing**

The Blob tool uses a binary method to convert images to black and white before counting the black or white contiguous pixel groups.

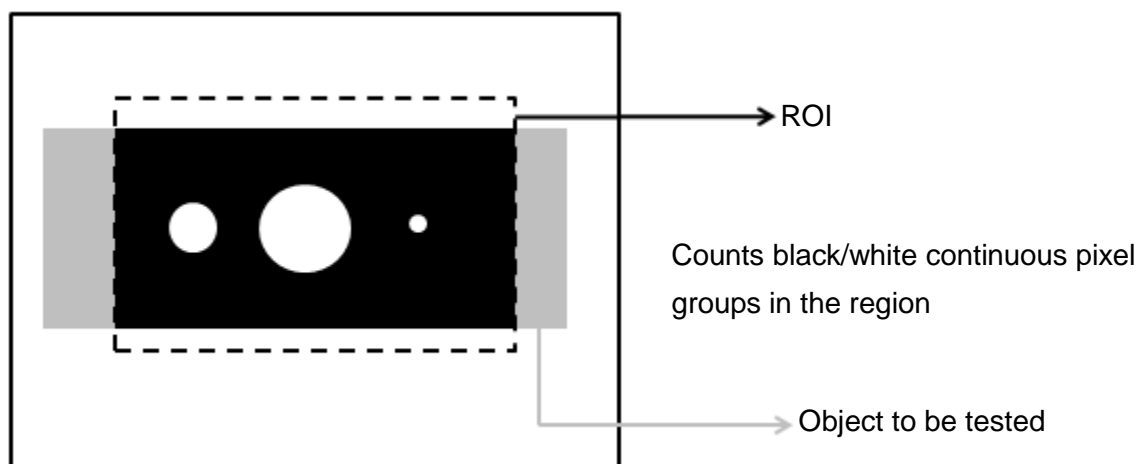

© **Procedural Results**

The Blob tool returns the following inspection results.

- Number of Blobs: outputs the number of black or white contiguous pixel groups.
- Blob Centroid Position X [N]: outputs the X coordinate of the centroid of the Nth black or white contiguous pixel group.
- Blob Centroid Position Y [N]: outputs the Y coordinate of the centroid of the Nth black or white contiguous pixel group.
- Blob Area [N]: outputs the area of the Nth black or white contiguous pixel group.
- Blob Perimeter [N]: outputs the perimeter of the Nth black or white contiguous pixel group.

◎ **Example**

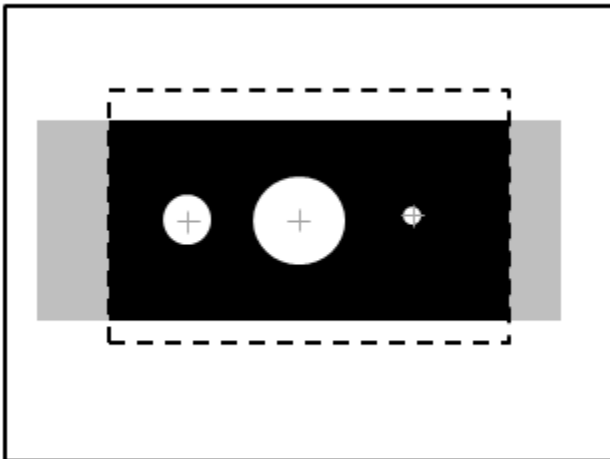

Number of Blobs: 3
 Blob Centroid Position X [1]: 1000
 Blob Centroid Position Y [1]: 500
 Blob Area [1]: 4000
 Blob Perimeter [1]: 1500

◎ **Blob dialog box**

The following picture shows the Blob inspection tool dialog box.

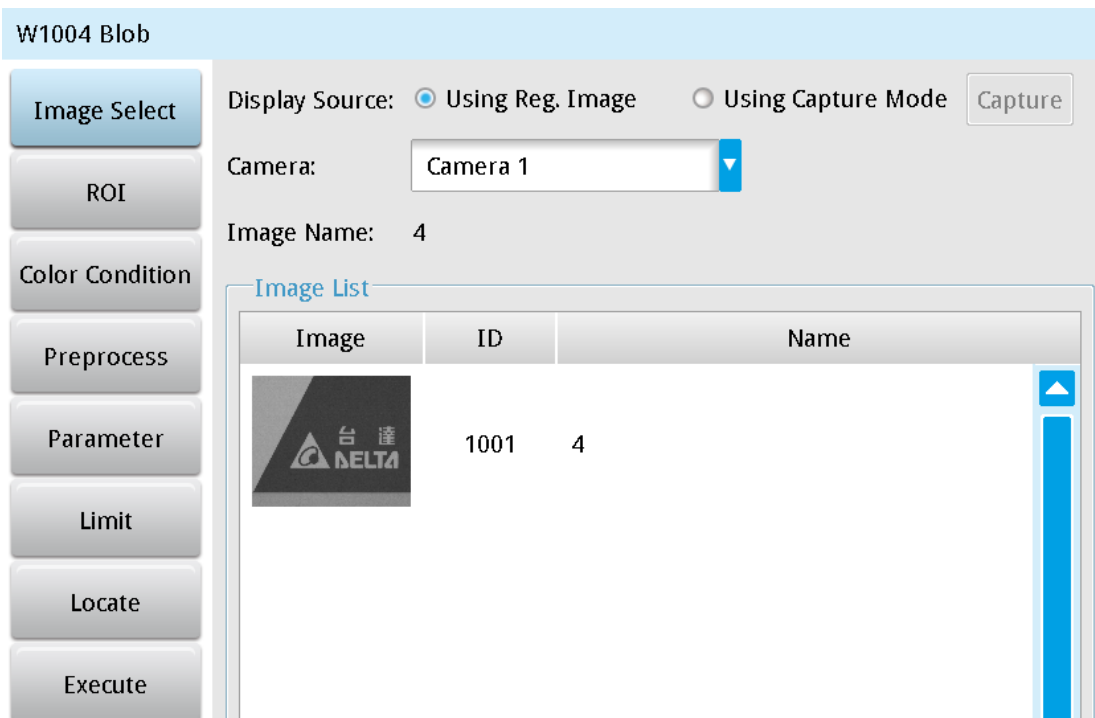

➤ **Image Select** (select Register Image)

Selects the image to be inspected from the register gallery. You can configure source cameras and inspect the image display source. When you select a different camera, the image table also switches to show the registered images acquired from that camera.

➤ **ROI** (configure detection region of interest)

Specifies the inspection regions to be used in the inspection. Optional ROI shapes include Rectangle, Circle, Arc, Ellipse, Ring, Polygon, and Rotated Rect. The Polygon ROI supports up to 16 points. In addition, there are up to eight mask functions to ignore particular segments.

► **Color Condition**

Specifies the color processing for images from a color camera: Color to Binary, Color to Grayscale, RGB grayscale, R Grayscale, G Grayscale, and B Grayscale.

► **Preprocess**

Specifies the image processing to apply before inspections to enhance certain aspects of the image.

Preprocessing methods include Binary, Dilation, Erosion, Average, Median, Laplacian, Sobel X, Sobel Y, Sobel XY, Brightness, Contrast, Shade, and Custom (filter). You can superimpose up to six methods or create a custom method by clicking **Custom**.

► **Parameter**

Adjusts the Blob inspection conditions.

Binary Limit

This function configures the upper and lower limits of the binary method that converts pixels in the configured range to white pixels, and converts the remaining pixels to black pixels. As shown in the following diagram, when you set the lower limit to 60 and the upper limit to 200, all gray scale values between 60 and 200 are converted to white, and the remaining pixels are converted to black.

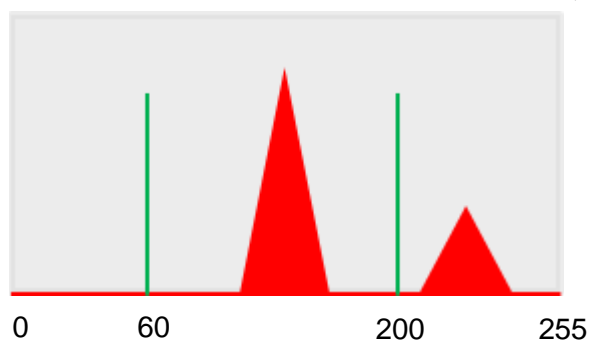

Detect Object

Specifies whether to count the number of blobs in white or black objects.

Blob Condition

Sort Rule: When searching multiple blobs, you can choose from the following blob sorting methods.

- 1) **Area Ascend/Descend:** When you configure Area Ascend, smaller areas are numbered first. For Area Descend, larger areas are numbered first.

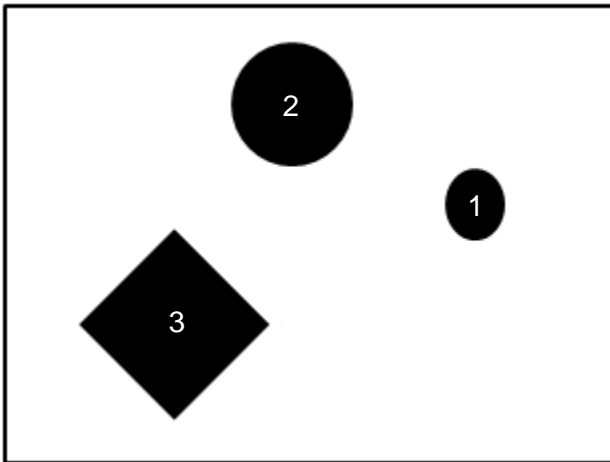

- 2) **Perimeter Ascend/Descend:** When you configure Perimeter Ascend, shorter perimeters are numbered first. For Perimeter Descend, longer perimeters are numbered first.

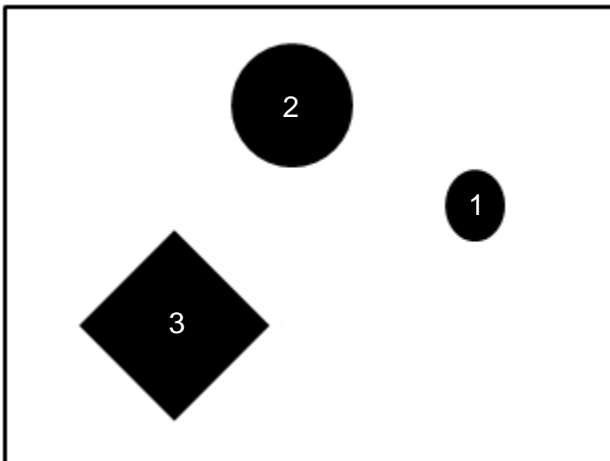

- 3) **Horizontal Center Position Ascend/Descend:** When you configure Horizontal Center Position Ascend, smaller Horizontal Center Position (coordinate values) are numbered first. For Horizontal Center Position Descend, larger Horizontal Center Position (coordinate values) are numbered first.

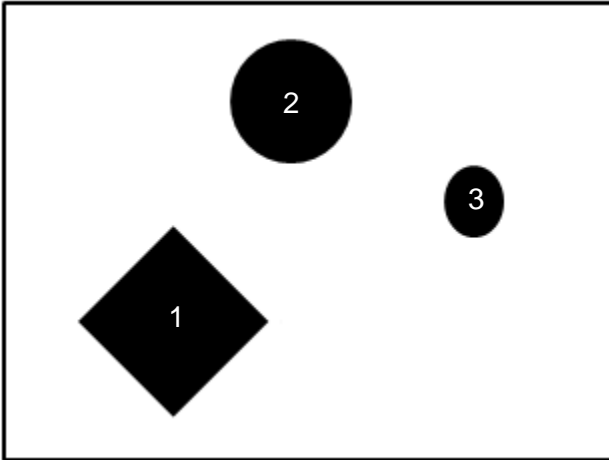

- 4) **Vertical Center Position Ascend/Descend:** When you configure Vertical Center Position Ascend, smaller Vertical Center Position (coordinate values) are numbered first. For Vertical Center Position Descend, larger Vertical Center Position (coordinate values) are numbered first.

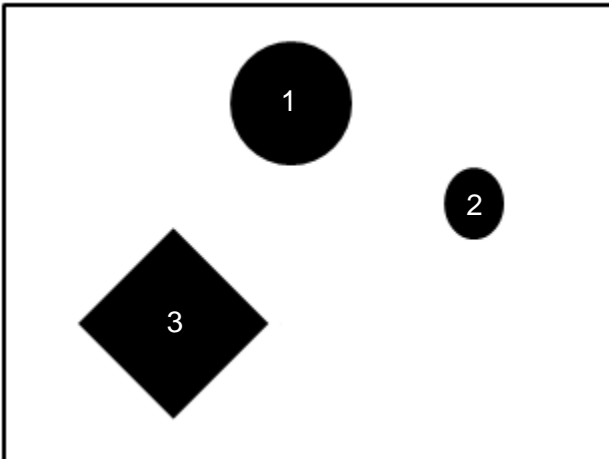

- 5) **Bounding Rectangle Horizontal Position Ascend/Descend:** When you configure Bounding Rectangle Horizontal Position Ascend, smaller Bounding Rectangle Horizontal Position (coordinate values) are numbered first. For Bounding Rectangle Horizontal Position Descend, larger Bounding Rectangle Horizontal Position (coordinate values) are numbered first.

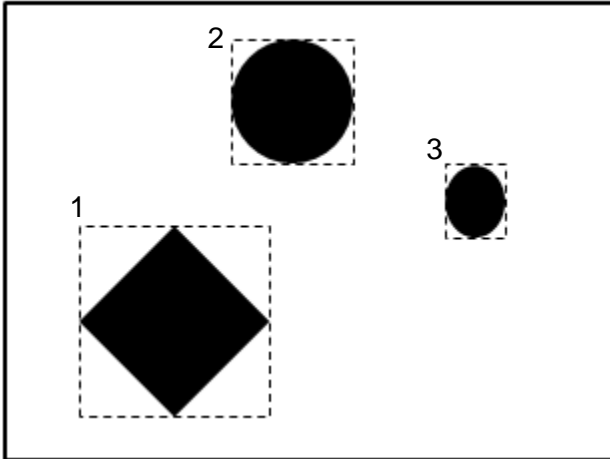

- 6) **Bounding Rectangle Vertical Position Ascend/Descend:** When you configure Bounding Rectangle Vertical Position Ascend, smaller Bounding Rectangle Vertical Position (coordinate values) are numbered first. For Bounding Rectangle Vertical Position Descend, larger Bounding Rectangle Vertical Position (coordinate values) are numbered first.

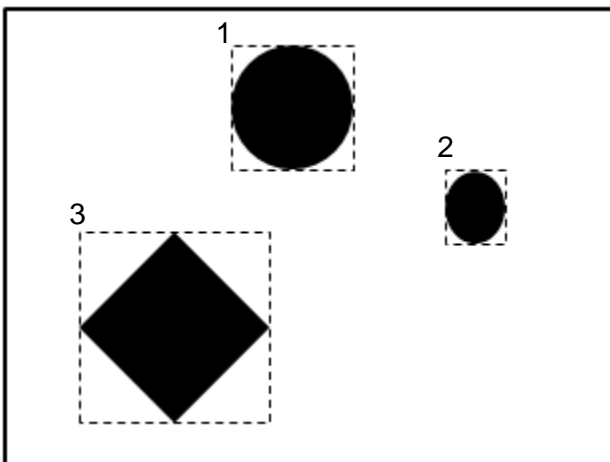

- 7) **Bounding Rectangle Width Ascend/Descend:** When you configure Bounding Rectangle Width Ascend is configured, shorter bounding rectangle widths are numbered first. For Bounding Rectangle Width Descend, longer bounding rectangle widths are numbered first.

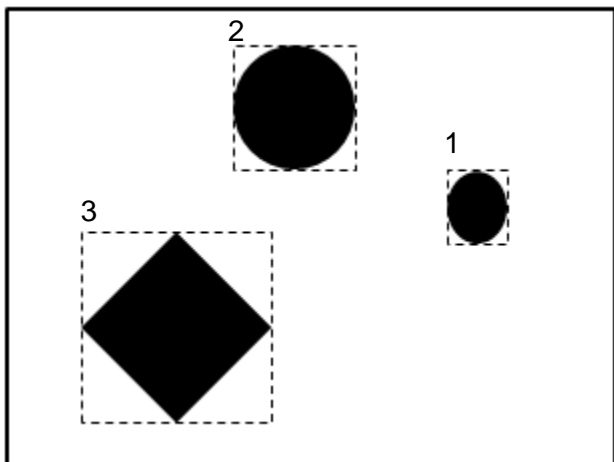

- 8) **Bounding Rectangle Height Ascend/Descend:** When you configure Bounding Rectangle Height Ascend, shorter bounding rectangle heights are numbered first. For Bounding Rectangle Height Descend, longer bounding rectangle heights are numbered first.

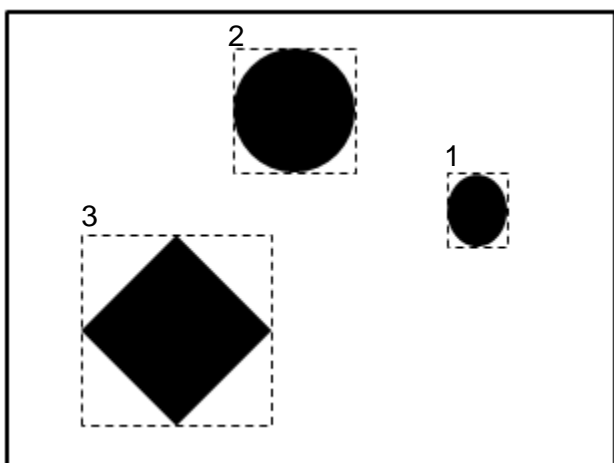

- 9) **Roundness Ascend/Descend:** When you configure Roundness Ascend, lesser roundness results are numbered first. For Roundness Descend, greater roundness results are numbered first.

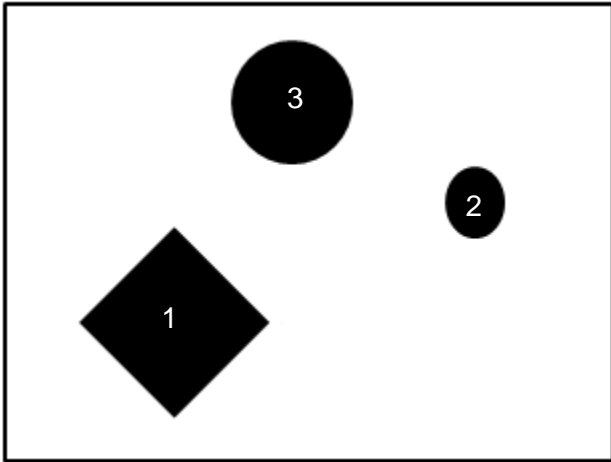

- 10) **Major Axis Angle Ascend/Descend:** When you configure Major Axis Angle Ascend (the white dotted line is the major axis), smaller angles between the major axis and the horizontal line are numbered first. For Major Axis Angle Descend, greater angles between the major axis and the horizontal line are numbered first.

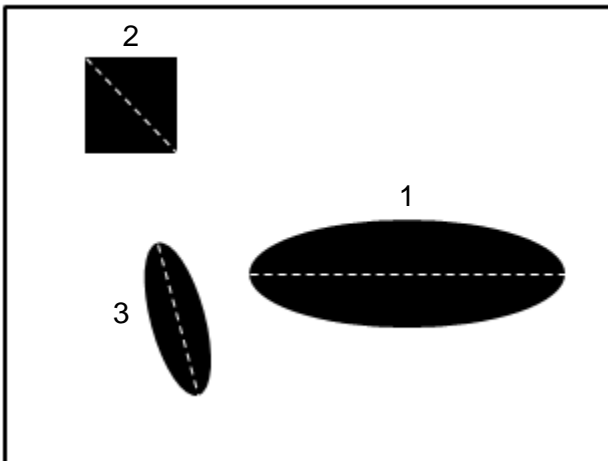

- 11) **Major Axis Length Ascend/Descend:** When you configure Major Axis Length Ascend (the white dotted line is the major axis), shorter major axis lengths are numbered first. For Major Axis Length Descend, longer major axis lengths are numbered first.

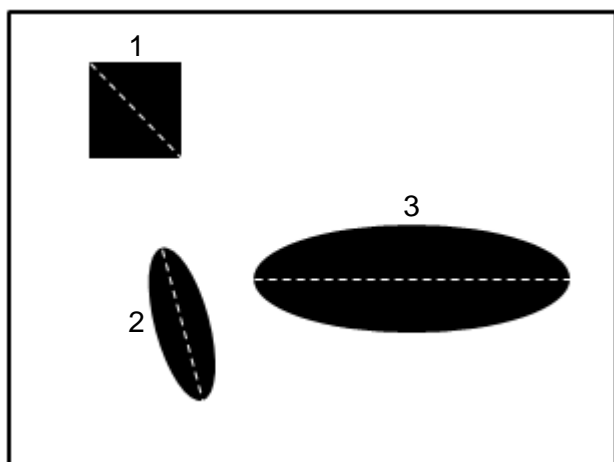

Reference

Output the Nth result when scanning multiple targets.

Origin

The position of the origin (0, 0) in System Setting is displayed on the upper left corner of the screen. You can enter the coordinates to change and move the origin to the new coordinates.

➤ Limit

After you complete the configurations, you can view the inspection results using register images through **Test Mode**. You can then configure the upper and lower limits in the Limit dialog box. You can configure the following items for the Blob tool.

Number of Blobs: the upper and lower limits for the number of blobs.

Blob Centroid Position X: the upper and lower X coordinate limits of blob centroids.

Blob Centroid Position Y: the upper and lower Y coordinate limits of blob centroids.

Blob Area: the upper and lower limits of Blob Area.

Blob Perimeter: the upper and lower limits of Blob Perimeter.

► Locate

Specifies whether the inspection region follows an inspection result by adjusting its coordinates (X, Y) and Angles (Theta). The inspection tools you can use as a reference includes Shape, Blob, Edge Position and Edge Angle. As shown in the following diagram, specific marks (such as the cross on the object) can be used for the Locate function.

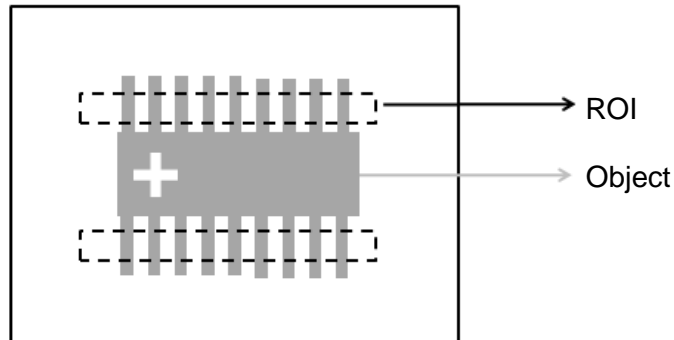

Locate Off

Locate On

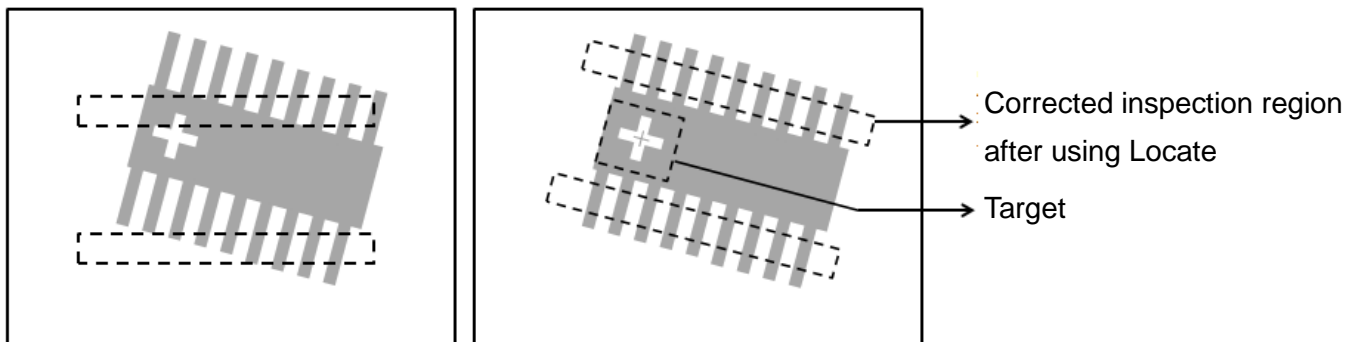

► Three tools are also provided in this item for quick configuration.

Tool

Ref. Previous Unit

Ref. Available Unit

Ref. Unit

Ref. X :	<input type="text" value="None"/>	<input type="button" value="Select"/>	<input type="button" value="CLEAR"/>
Ref. Y :	<input type="text" value="None"/>	<input type="button" value="Select"/>	<input type="button" value="CLEAR"/>
Ref. Angle :	<input type="text" value="None"/>	<input type="button" value="Select"/>	<input type="button" value="CLEAR"/>

◆ Reference Previous Unit

Selects the nearest inspection tool that can provide reference for Locate, and automatically fills in the **Ref. X**, **Ref. Y**, and **Ref. Angle** fields.

◆ Reference Available Unit

Selects the nearest unit with Locate configured, and automatically fills in the **Ref. X**, **Ref. Y**, and **Ref. Angle** fields.

◆ Reference Unit

Arbitrarily selects an inspection tool that can provide locating reference, and automatically fills in the **Ref. X**, **Ref. Y**, and **Ref. Angle** fields.

 **Reference** Please refer to Section 9.1 for detailed Location configurations.

⊙ Execute

Specifies whether to execute the inspection function in the inspection process.

➤ Always Execute

Always execute the inspection function in Run mode.

➤ Never Execute

Never execute the inspection function in Run mode.

⊙ Save

Saves all modified parameters and values.

⊙ Exit

Leaves the dialog box.

⊙ Output Item

➤ Window

Selects the output window for the total Judge result for the Blob tool on the designated interface.

➤ Item

- 1) **Number of Blobs**: outputs the number of blobs counted by the Blob tool.
- 2) **Blob Centroid Position X [N]**: outputs the centroid's X coordinate of the Nth blob found by the Blob tool.
- 3) **Blob Centroid Position Y [N]**: outputs the centroid's Y coordinate of the Nth blob found by the Blob tool.
- 4) **Maximum Blob Centroid Position X**: outputs the maximum centroid X coordinate found by the Blob tool.
- 5) **Minimum Blob Centroid Position X**: outputs the minimum centroid X coordinate found by the Blob tool.
- 6) **Maximum Blob Centroid Position Y**: outputs the maximum centroid Y coordinate found by the Blob tool.
- 7) **Minimum Blob Centroid Position Y**: outputs the minimum centroid Y coordinate found by the Blob tool.
- 8) **Blob Area [N]**: outputs the area of the Nth blob found by the Blob tool.

- 9) **Maximum Blob Area:** outputs the maximum area found by the Blob tool.
- 10) **Minimum Blob Area:** outputs the minimum area found by the Blob tool.
- 11) **Blob Roundness [N]:** outputs the roundness of the Nth blob found by the Blob tool.
- 12) **Maximum Blob Roundness:** outputs the maximum roundness found by the Blob tool.
- 13) **Minimum Blob Roundness:** outputs the minimum roundness found by the Blob tool.
- 14) **Blob Major Axis Angle [N]:** outputs the angle of the Nth blob relative to the major axis found by the Blob tool.
- 15) **Maximum Blob Major Axis Angle:** outputs the maximum angle relative to the major axis found by the Blob tool.
- 16) **Minimum Blob Major Axis Angle:** outputs the minimum angle relative to the major axis found by the Blob tool.
- 17) **Blob Perimeter [N]:** outputs the perimeter of the Nth blob found by the Blob tool.
- 18) **Maximum Blob Perimeter:** outputs the maximum perimeter found by the Blob tool.
- 19) **Minimum Blob Perimeter:** outputs the minimum perimeter found by the Blob tool.
- 20) **Blob X Feret Diameter [N]:** outputs the Feret diameter of the Nth blob in the X direction found by the Blob tool.
- 21) **Blob Y Feret Diameter [N]:** outputs the Feret diameter of the Nth blob in the Y direction found by the Blob tool.
- 22) **Maximum Blob X Feret Diameter:** outputs the maximum Feret diameter in the X direction found by the Blob tool.
- 23) **Minimum Blob X Feret Diameter:** outputs the minimum Feret diameter in the X direction found by the Blob tool.
- 24) **Maximum Blob Y Feret Diameter:** outputs the maximum Feret diameter in the Y direction found by the Blob tool.
- 25) **Minimum Blob Y Feret Diameter:** outputs the minimum Feret diameter in the Y direction found by the Blob tool.
- 26) **Blob Bounding Rectangle Upper Left Position X [N]:** outputs the upper left X coordinate of the bounding rectangle for the Nth blob found by the Blob tool.
- 27) **Blob Bounding Rectangle Upper Left Position Y [N]:** outputs the upper left Y coordinate of the bounding rectangle for the Nth blob found by the Blob tool.
- 28) **Blob Major Axis Length [N]:** outputs the length of the major axis for the Nth blob found by the Blob tool.
- 29) **Maximum Blob Major Axis Length:** outputs the maximum length of the major axis found by the Blob tool.
- 30) **Minimum Blob Major Axis Length:** outputs the minimum length of the major axis found by the Blob tool.
- 31) **Blob ID:** outputs the ID of the inspection tool.
- 32) **Number of Blobs (J):** outputs the logical (Judge) result for the number of blobs counted by the Blob tool.

- 33) **Blob Centroid Position X (J) [N]**: outputs the logical (Judge) result for the centroid's X coordinate of the Nth blob found by the Blob tool.
- 34) **Blob Centroid Position Y (J) [N]**: outputs the logical (Judge) result for the centroid's Y coordinate of the Nth blob found by the Blob tool.
- 35) **Blob Area (J) [N]**: outputs the logical (Judge) result for the area of the Nth blob found by the Blob tool.
- 36) **Blob Perimeter (J) [N]**: outputs the logical (Judge) result for the perimeter of the Nth blob found by the Blob tool.

5.3 Stain

You can use the Stain tool to detect stains in a fixed direction, such as scrapes and smears on the object.

⊙ **Algorithmic Processing**

You must first specify the scan direction and the width, height, and offset of the scanned segment. During each scan, the controller calculates the average gray scale value within the scanned segment, and compares this value with the previously scanned result. When the difference exceeds the Stain Threshold and the area exceeds Stain Area, the system recognizes the segment as a stain.

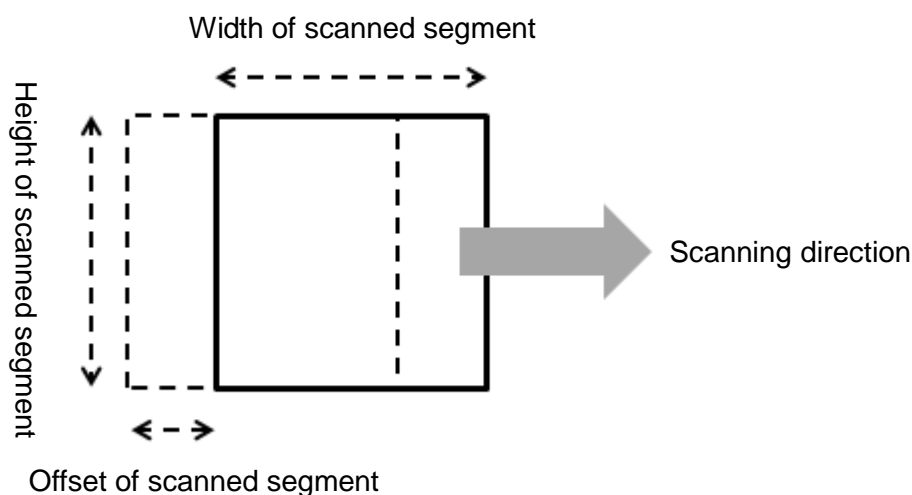

► Stain Scanning Methods

Stain includes various ROI options when you choose the Stain scanning methods. All types of ROIs can be scanned in horizontal, vertical, or horizontal-vertical directions. You can still use horizontal and vertical scanning to inspect stains in the vertical and horizontal directions.

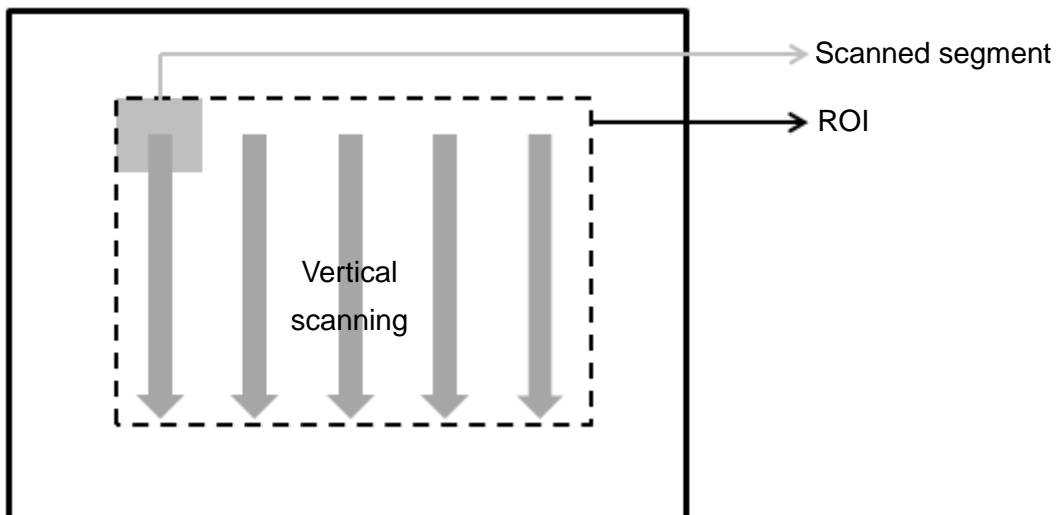
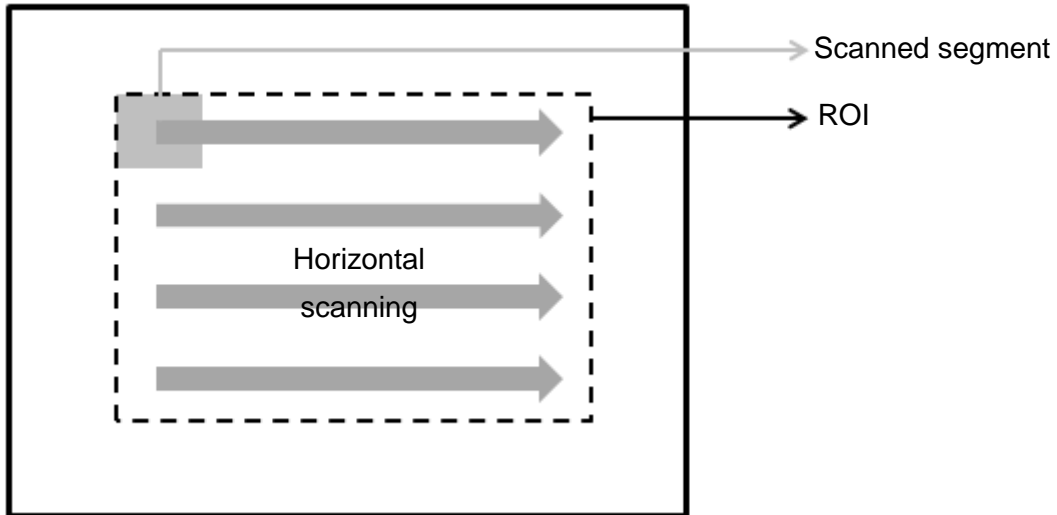

- ◆ When the ROI is Circle, Ring, or Arc, you can also select the tangential and radial directions in addition to horizontal, vertical, and horizontal–vertical scanning. You can use tangential and radial scanning to inspect stains in the radial and tangential directions.

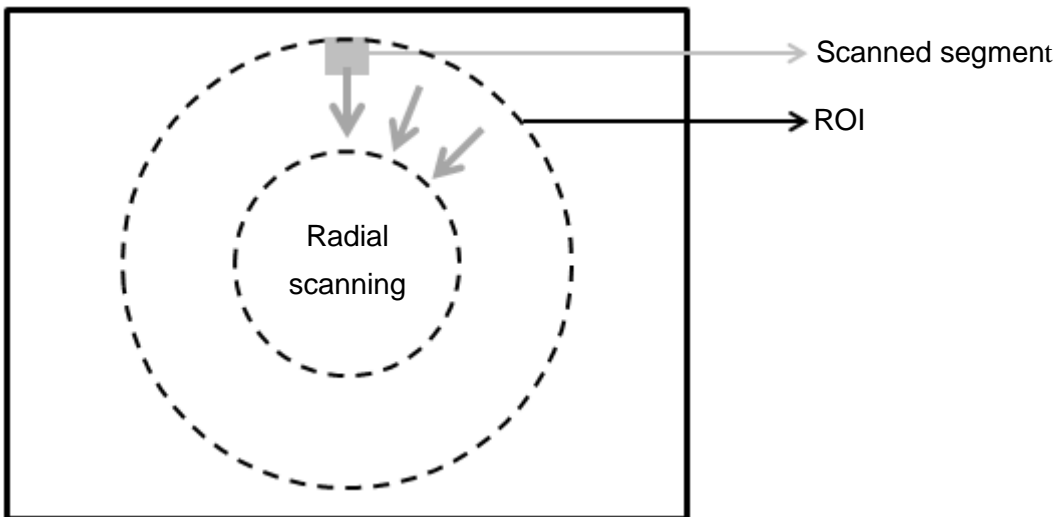
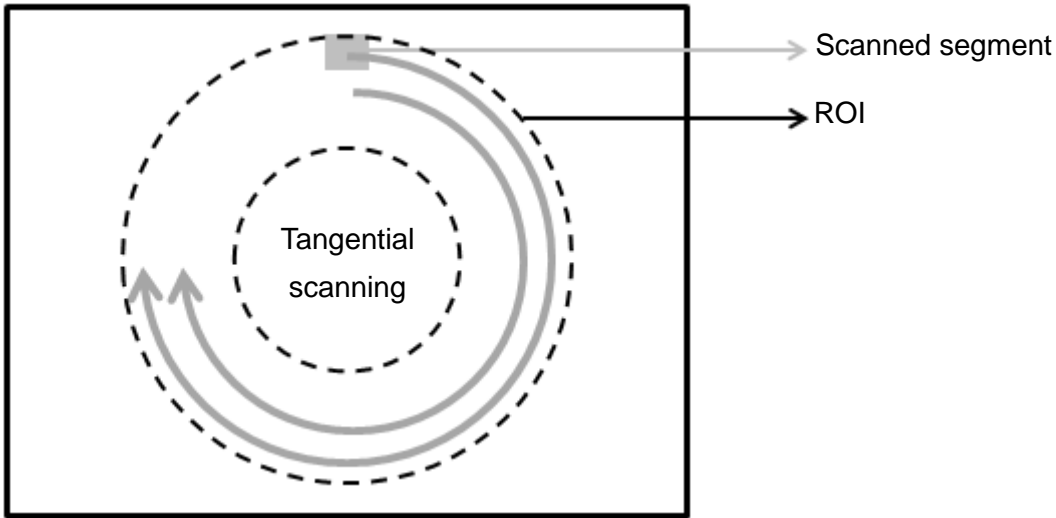

© Procedural Results

The Stain tool returns the following inspection results.

- Total Area of Stains: outputs the sum of stain area inspected.
- Stain Area [N]: outputs the area of the Nth stain inspected.
- Stain Centroid Position X [N]: outputs the X coordinate of the Nth stain inspected.
- Stain Centroid Position Y [N]: outputs the Y coordinate of the Nth stain inspected.
- Stain Search Count: outputs the number of stains inspected.

© **Example**

As shown in the following picture, the system finds three scrapes in the vertical direction using horizontal scanning.

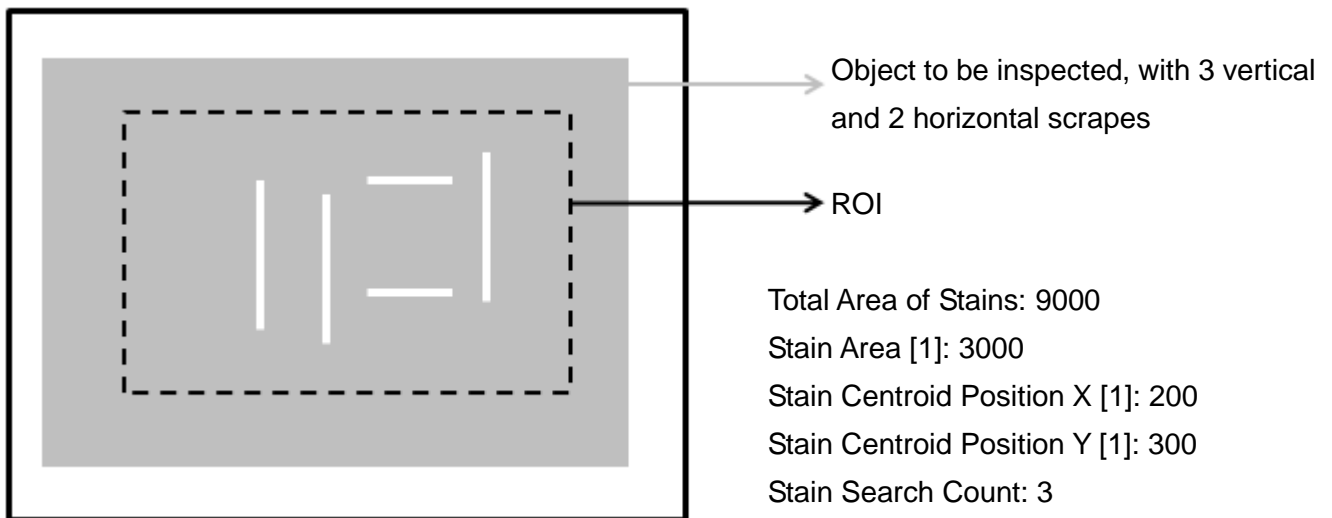

As shown in the following diagram, the system finds two scrapes in the horizontal direction using vertical scanning.

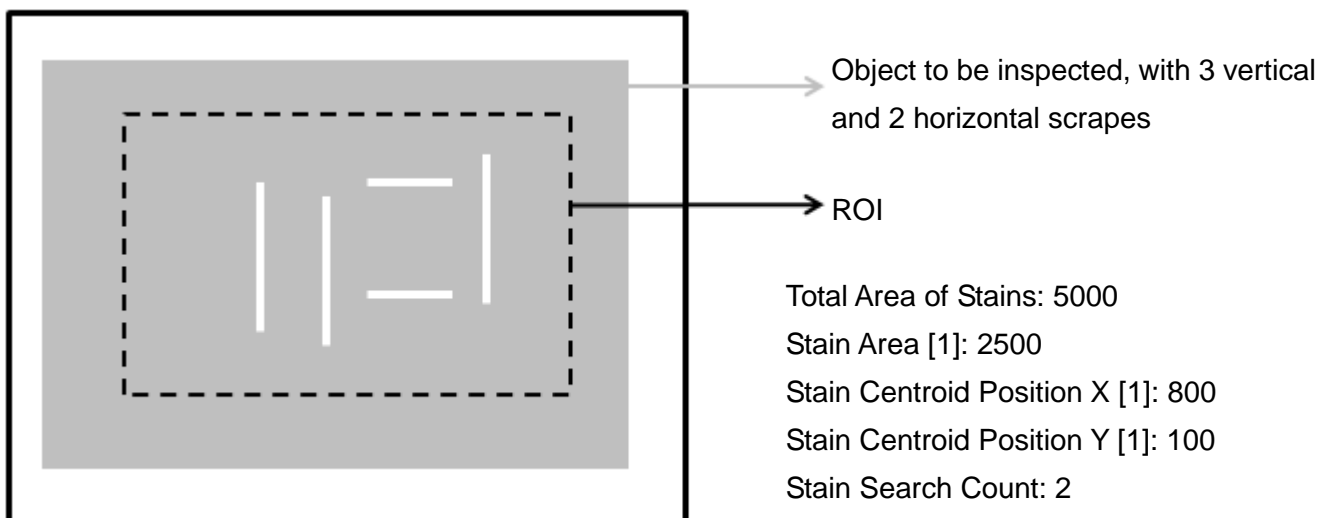

Chapter 5 Inspection

As shown in the following diagram, the system finds five scrapes in the vertical and horizontal directions using horizontal and vertical scanning.

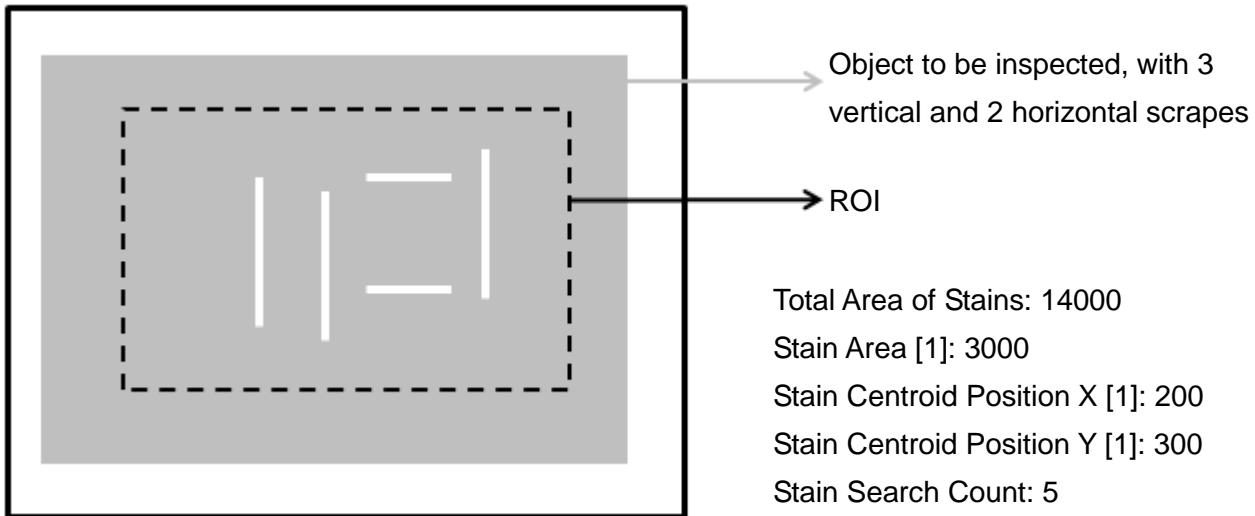

As shown in the following diagram, the system finds one scrape in the radial direction using tangential scanning.

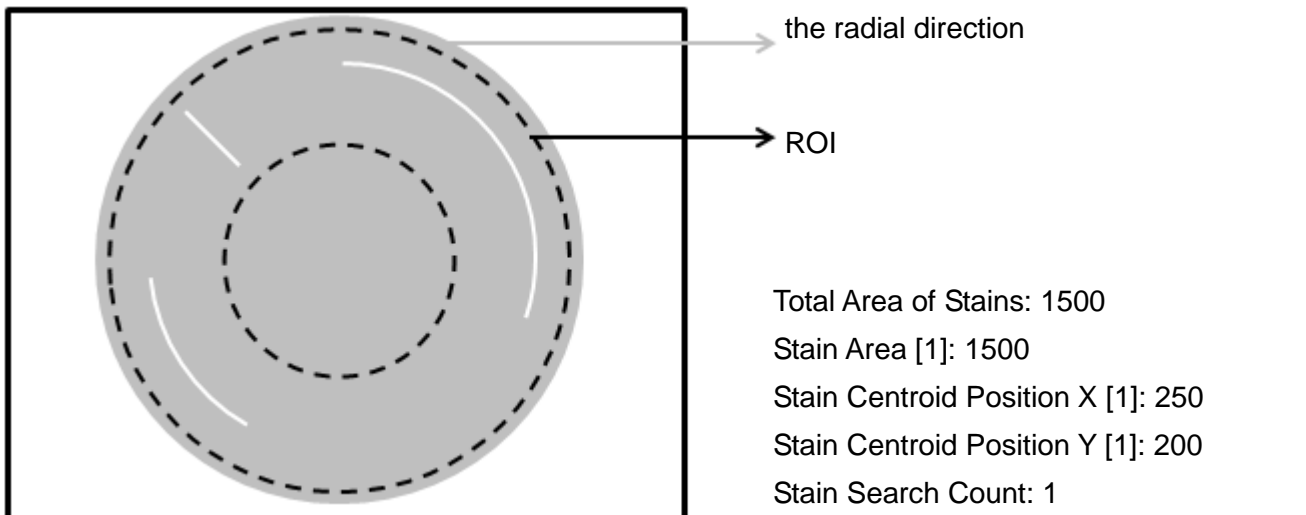

As shown in the following diagram, the system finds two scrapes in the tangential direction using radial scanning.

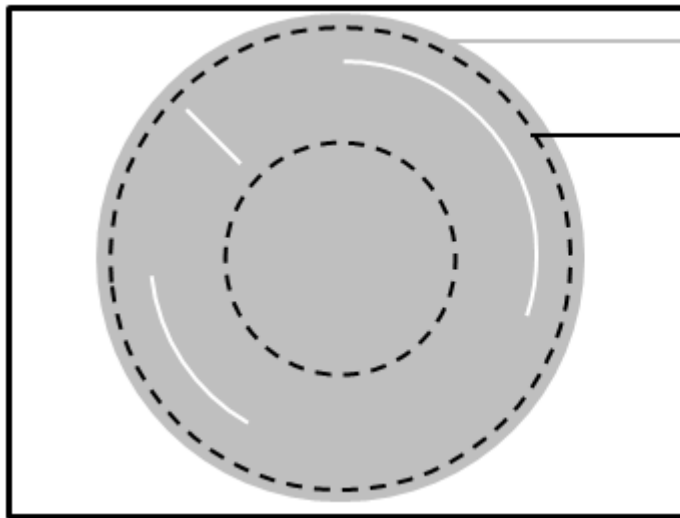

Object to be inspected, with 2 tangential and 1 radial scrapes

ROI

Total Area of Stains: 9000

Stain Area [1]: 6000

Stain Centroid Position X [1]: 900

Stain Centroid Position Y [1]: 250

Stain Search Count: 2

◎ Stain dialog box

The following picture shows the Stain inspection tool dialog box.

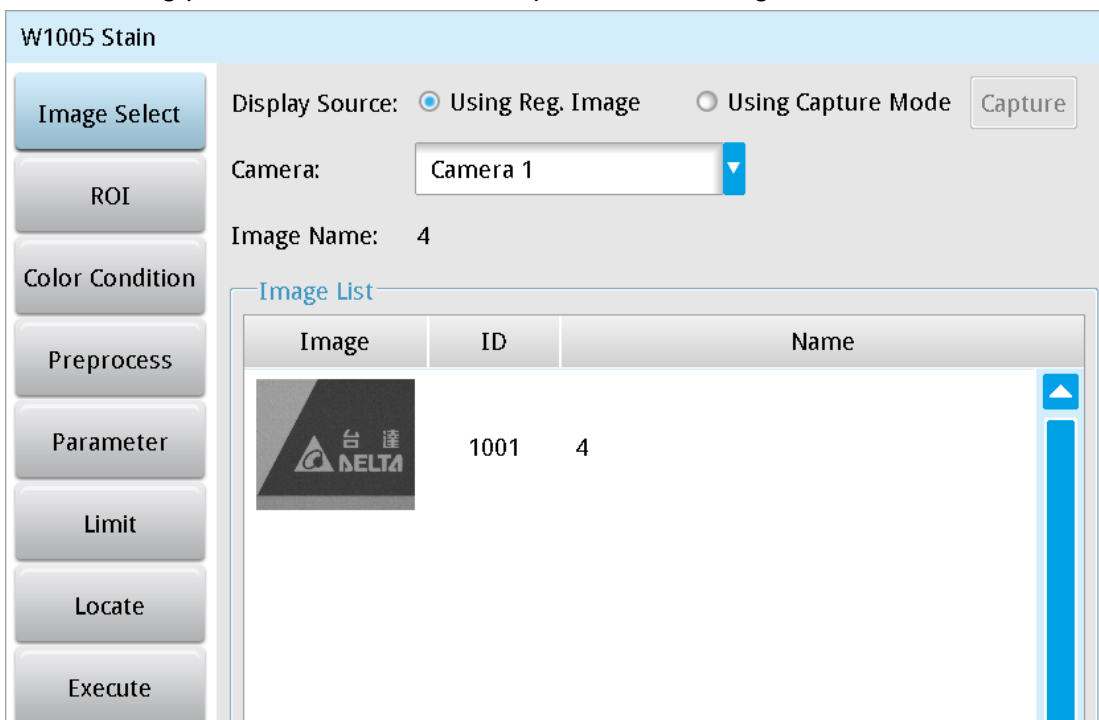

➤ Image Select (select Register Image)

Selects the image to be inspected from the register gallery. You can configure source cameras and inspect the image display source. When you select a different camera, the image table also switches to show the registered images acquired from that camera.

► **ROI** (configure detection region of interest)

Specifies the inspection regions to be used in the inspection. Optional ROI shapes include Rectangle, Circle, Arc, Ellipse, Ring, Polygon, and Rotated Rect. The Polygon ROI supports up to 16 points. In addition, there are up to eight mask functions to ignore particular segments.

► **Color Condition**

Specifies the color processing for images from a color camera: Color to Binary, Color to Grayscale, RGB grayscale, R Grayscale, G Grayscale, and B Grayscale.

► **Preprocess**

Specifies the image processing to apply before inspections to enhance certain aspects of the image. Preprocessing methods include Binary, Dilation, Erosion, Average, Median, Laplacian, Sobel X, Sobel Y, Sobel XY, Brightness, Contrast, Shade, and Custom (filter). You can superimpose up to six methods or create a custom method by clicking **Custom**.

► **Parameter**

Adjusts the Stain inspection tool conditions.

Scanning Direction

Specifies the scanning directions for horizontal/vertical scanning; you can select tangential or radial scanning for Circle, Ring, and Arc ROIs.

Sort Rule

Specifies the basis for sorting stains; options include Horizontal Ascend, Horizontal Descend, Vertical Ascend, Vertical Descend, Area Ascend, Area Descend, Level Ascend, and Level Descend.

Segment Width/Height

Specifies the segment size to be scanned.

Segment Offset

Specifies the offset of the segment to be scanned.

Stain Threshold

Specifies the threshold for stains. The system finds the difference between the average gray scale values during each scan. When this difference exceeds the Stain Threshold, the system recognizes the segment as a stain. You can use this parameter as the basis for determining the shade of the stain.

Stain Area

Specifies the area required to recognize a segment as a stain; this parameter can be used as a basis for determining stain size.

Reference

Outputs the Nth result when scanning multiple targets.

Number

Specifies the number of stains to search for, up to a maximum of 9999.

Origin

The position of the origin (0, 0) in System Setting is displayed on the upper left corner of the screen. You can enter new coordinates to move the origin to the new coordinates.

➤ Limit

After you complete the configurations, you can view the inspection results using register images through **Test Mode**. You can then configure the upper and lower limits in the Limit dialog box. The following items can be configured for the Stain tool.

Total Area: the upper and lower limits of Total Area.

Area: the upper and lower limits of Area.

Centroid Position X: the upper and lower limits of centroid position in the X direction.

Centroid Position Y: the upper and lower limits of centroid position in the Y direction.

Search Count: the upper and lower limits for Search Count.

➤ Locate

Specifies whether the inspection region follows an inspection result by adjusting its coordinates (X, Y) and Angles (Theta). The inspection tools you can use as a reference includes Shape, Blob, Edge Position and Edge Angle. As shown in the following diagram, specific marks (such as the cross on the object) can be used for the Locate function.

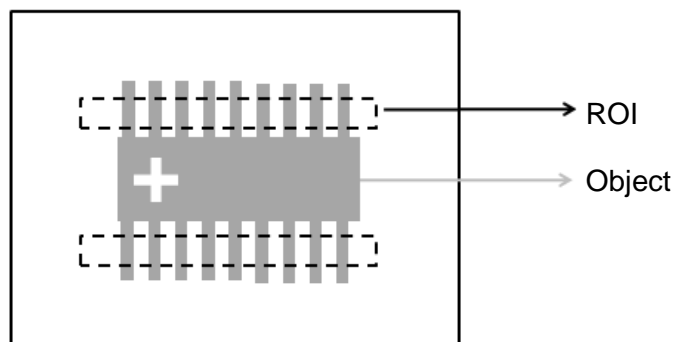

Locate Off

Locate On

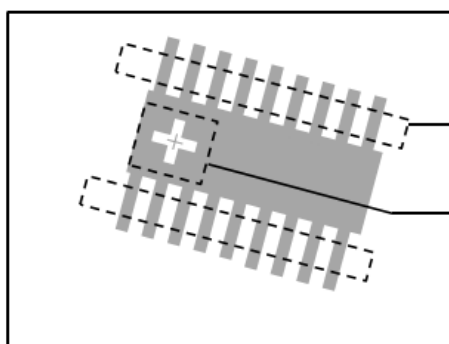
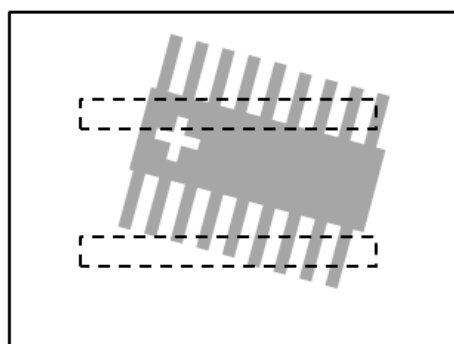

➤ Three tools are also provided in this item for quick configuration.

Tool

Ref. Previous Unit

Ref. Available Unit

Ref. Unit

Ref. X :

None

Select

CLEAR

Ref. Y :

None

Select

CLEAR

Ref. Angle :

None

Select

CLEAR

◆ **Reference Previous Unit**

Selects the nearest inspection tool that can provide reference for Locate, and automatically fills in the **Ref. X**, **Ref. Y**, and **Ref. Angle** fields.

◆ **Reference Available Unit**

Selects the nearest unit with Locate configured, and automatically fills in the **Ref. X**, **Ref. Y**, and **Ref. Angle** fields.

◆ Reference Unit

Arbitrarily selects an inspection tool that can provide locating reference, and automatically fills in the **Ref. X**, **Ref. Y**, and **Ref. Angle** fields.

 **Reference** Please refer to Section 9.1 for detailed locating configurations.

⊙ Execute

Specifies whether to execute the inspection function in the inspection process.

➤ Always Execute

Always execute the inspection function in Run mode.

➤ Never Execute

Never execute the inspection function in Run mode.

⊙ Save

Saves all modified parameters and values.

⊙ Exit

Leaves the dialog box.

⊙ Output Item

➤ Window

Selects the output window for the total Judge result for the Stain tool on the designated interface.

➤ Item

- 1) **Total Area of Stains:** outputs the total area accumulated by the Stain tool.
- 2) **Stain Search Count:** outputs the number of Stains found by the Stain tool.
- 3) **Stain Area [N]:** outputs the area of the Nth stain found by the Stain tool.
- 4) **Maximum Stain Area:** outputs the maximum area found by the Stain tool.
- 5) **Minimum Stain Area:** outputs the minimum area found by the Stain tool.
- 6) **Stain Centroid Position X [N]:** outputs the centroid's X coordinate of the Nth stain found by the Stain tool.
- 7) **Stain Centroid Position Y [N]:** outputs the centroid's Y coordinate of the Nth stain found by the Stain tool.
- 8) **Maximum Stain Centroid Position X:** outputs the maximum centroid X coordinate found by the Stain tool.
- 9) **Minimum Stain Centroid Position X:** outputs the minimum centroid X coordinate found by the Stain tool.
- 10) **Maximum Stain Centroid Position Y:** outputs the maximum centroid Y coordinate found by the Stain tool.
- 11) **Minimum Stain Centroid Position Y:** outputs the minimum centroid Y coordinate found by the Stain tool.
- 12) **Stain ID:** outputs the ID of the inspection tool.

- 13) **Total Area of Stains (J)**: outputs the logical (Judge) result of the total area accumulated by the Stain tool.
- 14) **Stain Search Count (J)**: outputs the logical (Judge) result for the number of stains found by the Stain tool.
- 15) **Stain Area (J) [N]**: outputs the logical (Judge) result for the area of the Nth stain found by the Stain tool.
- 16) **Stain Centroid Position X (J) [N]**: outputs the logical (Judge) result for the centroid X coordinate of the Nth stain found by the Stain tool.
- 17) **Stain Centroid Position Y (J) [N]**: outputs the logical (Judge) result for the centroid Y coordinate of the Nth stain found by the Stain tool.

5.4 Edge Angle

This tool searches for the two edge points formed by brightness differences on a gray scale image, and finds the relative angle created by the average coordinates. You can configure the search region and the scanning width on each side. The tool finds the two edge points at the two ends of the search region through horizontal scanning. Next, the tool regresses two points through the Average function to draw a straight line, and calculates the angle of inclination of the straight line against the horizontal axis. When scanning wider edges, more points are acquired, leading to more accurate measurement of the angles.

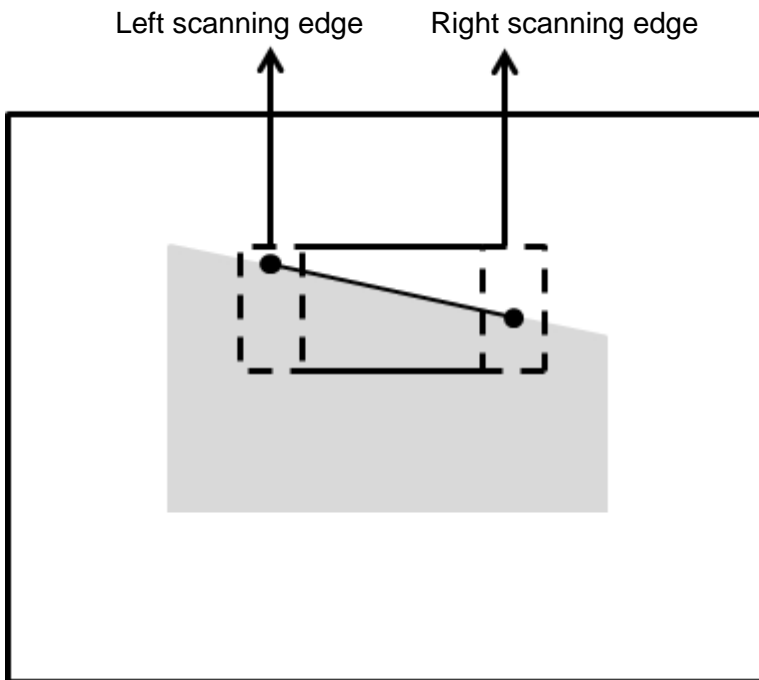

◎ **Algorithmic Processing**

➤ **Edge Angle Scan Methods**

Specifies the ROI and calculates the relative angles according to the four scanning directions.

Scanning direction: Downward

Search method: All edges

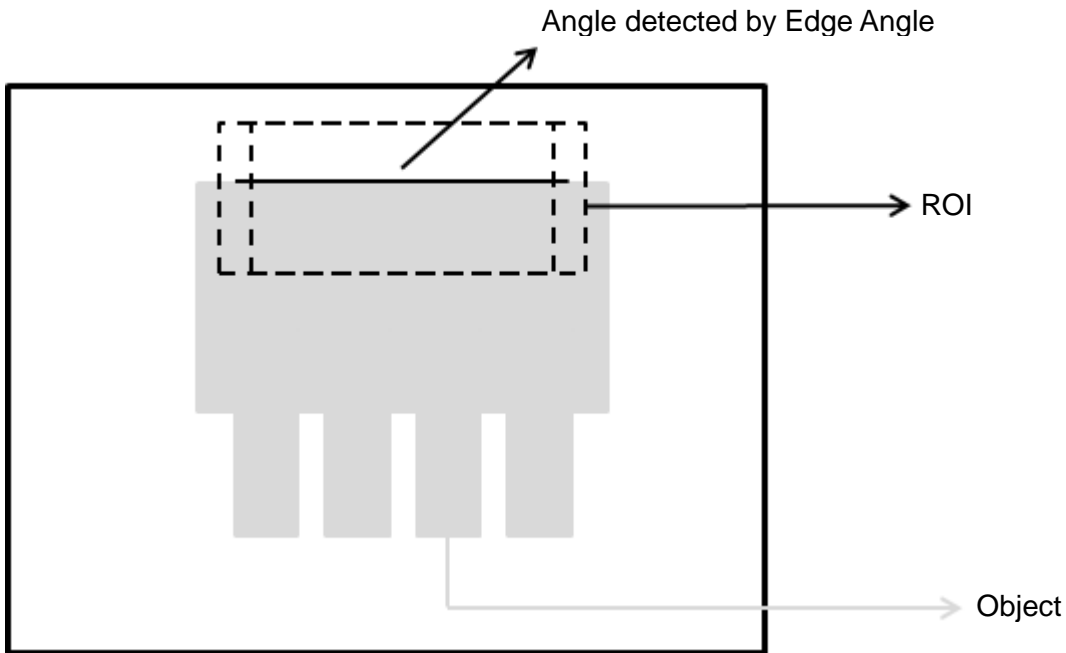

Scanning direction: Right to left

Search method: Bright to dark

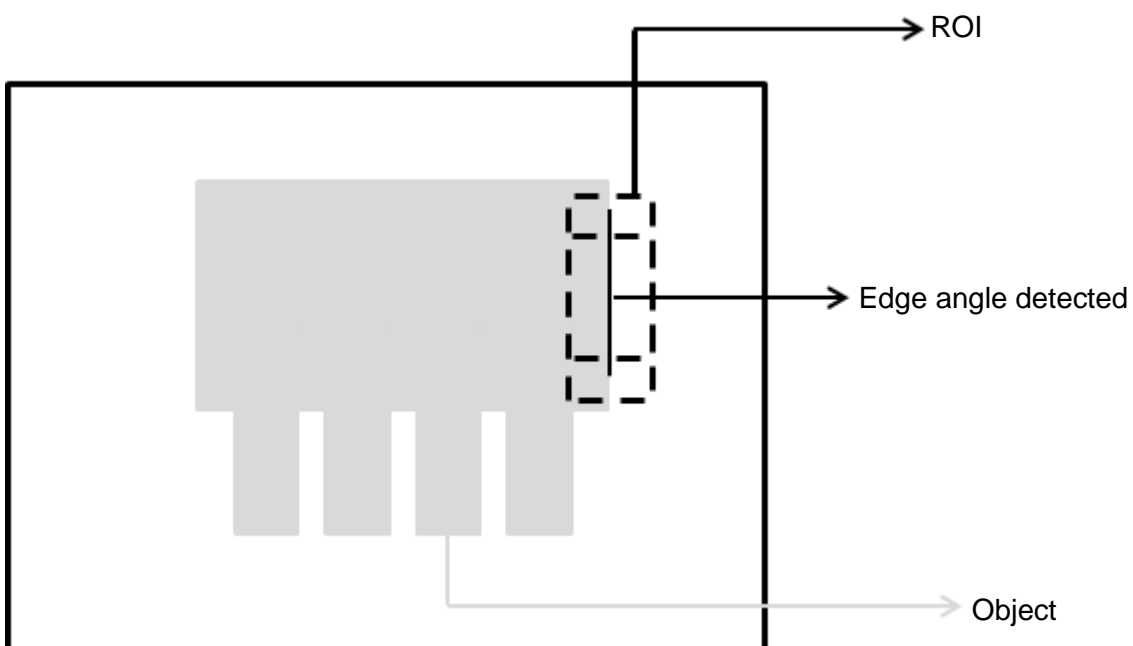

© Procedural Results

The Edge Angle tool returns the following inspection results.

- Edge Angle: outputs the angle from two points on the edge found by the Edge Angle tool.
- Upper Edge Position X: outputs the X coordinate of the first edge position encountered in the scanning direction from the two points found by the Edge Position tool.
- Upper Edge Position Y: outputs the Y coordinate of the first edge position encountered in the scanning direction from the two points found by the Edge Position tool.
- Lower Edge Position X: outputs the X coordinate of the second edge position encountered in the scanning direction from the two points found by the Edge Position tool.
- Lower Edge Position Y: outputs the Y coordinate of the second edge position encountered in the scanning direction from the two points found by the Edge Position tool.

© Example

Scanning direction: Downward

Search method: All edges

Inspection result: Absolute angle is 0 degrees

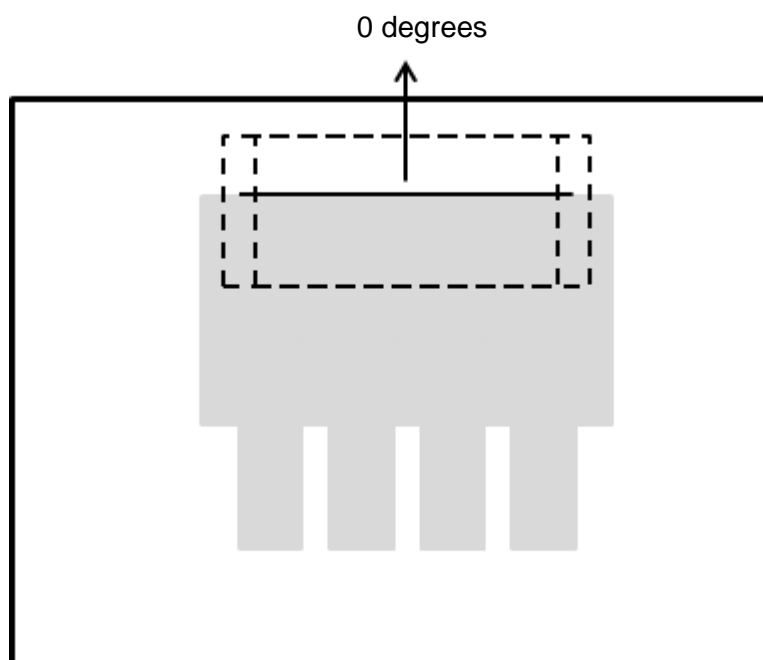

Scanning direction: Right to left

Search method: Bright to dark

Inspection result: Absolute angle is 14 degrees

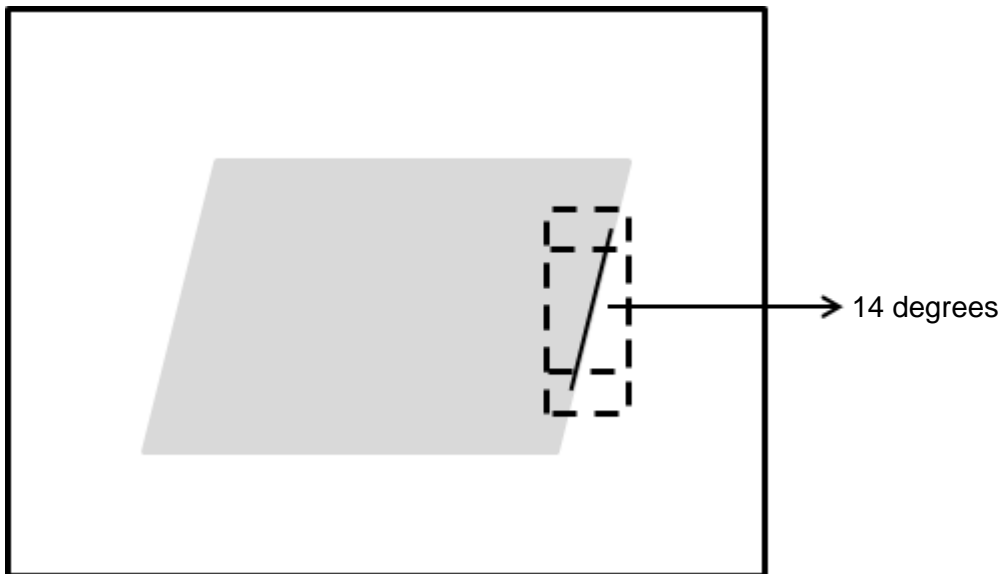

◎ Edge Angle dialog box

The following picture shows the Edge Angle inspection tool dialog box.

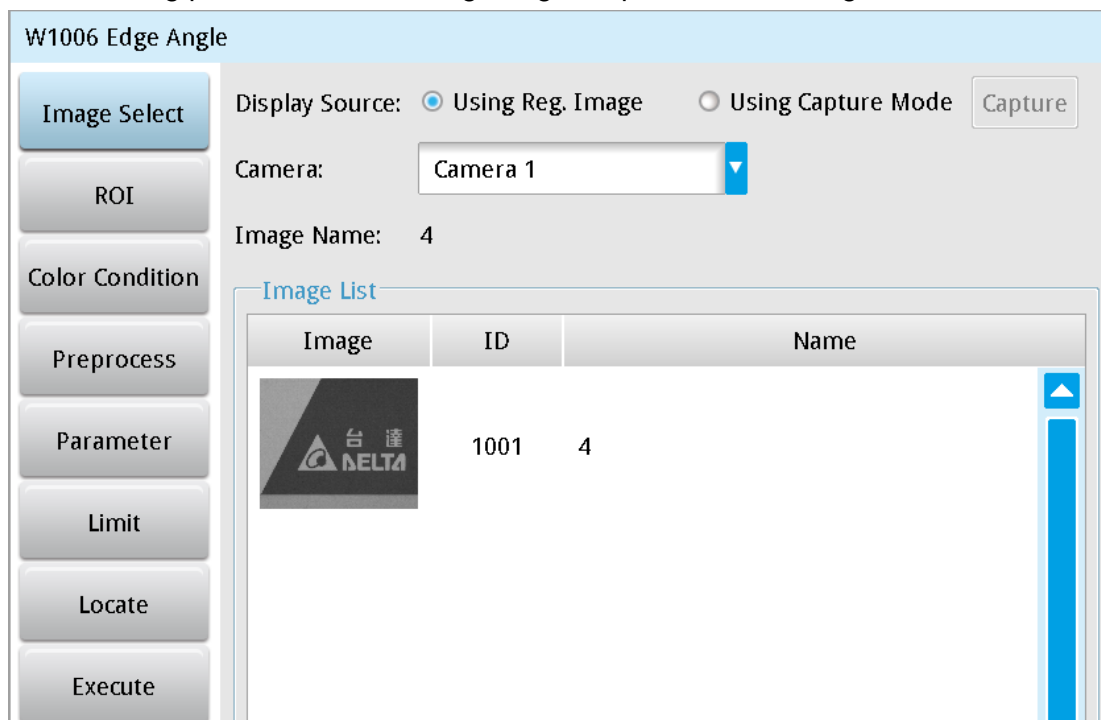

➤ Image Select (select Register Image)

Selects the image to be inspected from the register gallery. You can configure source cameras and inspect the image display source. When you select a different camera, the image table also switches to show the registered images acquired from that camera.

► **ROI** (configure detection region)

Specifies the inspection regions to be used in the inspection. The rectangle shape is the only ROI available for Edge Angle.

► **Color Condition**

Specifies the color processing for images from a color camera: Color to Binary, Color to Grayscale, RGB grayscale, R Grayscale, G Grayscale, and B Grayscale.

► **Preprocess**

Specifies the image processing to apply before inspections to enhance certain aspects of the image. Preprocessing methods include Binary, Dilation, Erosion, Average, Median, Laplacian, Sobel X, Sobel Y, Sobel XY, Brightness, Contrast, Shade, and Custom (filter). You can superimpose up to six methods or create a custom method by clicking **Custom**.

► **Parameter**

Adjusts the Edge Angle inspection conditions.

Edge Filter

Direction

Rectangle is the only ROI option in Edge Angle. You can select the scanning mode: Left to Right, Right to Left, Downward, and Upward.

Look For

You can configure the search method and choose the search modes: All Edges, Light to Dark, and Dark to Light.

Edge Strength

Specifies the threshold for the edge search (**Look For**), and you can fine-tune it between 0–100 based on the waveform displayed in the preview. When the peak is larger than the configured edge strength, **Look For** identifies the segment as an edge. As shown in the lower left picture, the system finds two edges when Edge Strength is set to 50. As shown in the lower right diagram, the system finds only one edge that is greater than the configured Edge Strength threshold of 70.

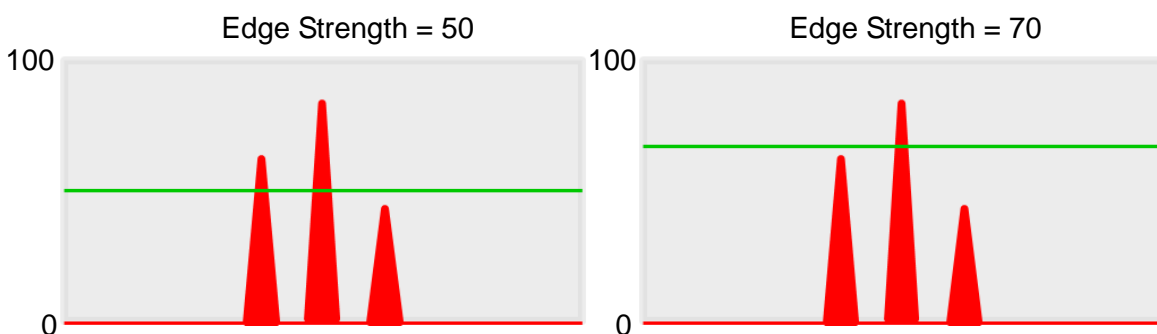

Lower

Use the Lower (limit) to filter small noise signals on the image, and the range is between 0–255. Peaks lower than the Lower value are filtered from the waveform. As shown in the lower left diagram, some noise appears when Lower is set to 0, but the noise is filtered out when Lower is set to 20.

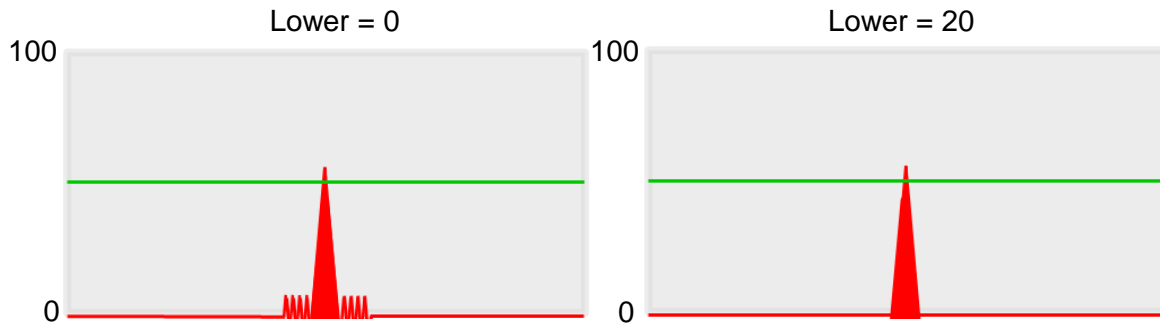

Smoothing

Sets the RGB Grayscale for edge calculations between 1–30. When you increase Smoothing, the slope of waveform changes, attenuating the effect caused by noise signals.



➤ Limit

After you complete the configurations, you can view the inspection results using register images through **Test Mode**. You can then configure the upper and lower limits in the Limit dialog box. The following items can be configured for the Edge Angle tool.

Angle

Specifies the Upper and Lower limits of the angles detected by Edge Angle.

➤ Locate

Specifies whether the inspection region follows an inspection result by adjusting its coordinates (X, Y) and Angles (Theta). The inspection tools you can use as a reference includes Shape, Blob, Edge Position and Edge Angle. As shown in the following diagram, specific marks (such as the cross on the object) can be used for the Locate function.

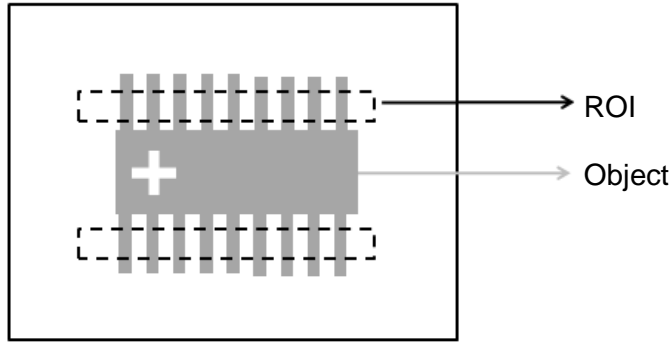

Locate Off

Locate On

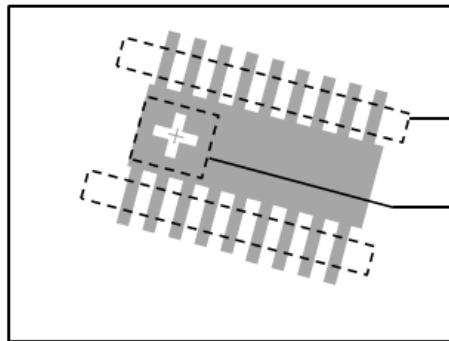
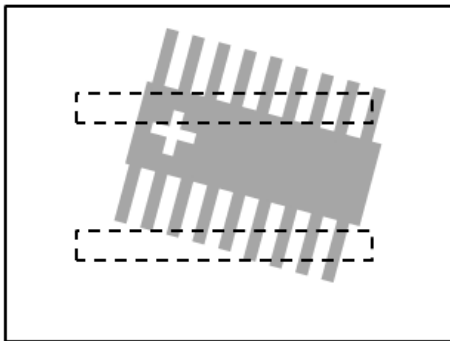

➤ Three tools are also provided in this item for quick configuration.

Tool

Ref. Previous Unit

Ref. Available Unit

Ref. Unit

Ref. X :

Ref. Y :

Ref. Angle :

◆ **Reference Previous Unit**

Selects the nearest inspection tool that can provide reference for Locate, and automatically fills in the **Ref. X**, **Ref. Y**, and **Ref. Angle** fields.

◆ **Reference Available Unit**

Selects the nearest unit with Locate configured, and automatically fills in the **Ref. X**, **Ref. Y**, and **Ref. Angle** fields.

◆ **Reference Unit**

Arbitrarily selects an inspection tool that can provide locating reference, and automatically fills in the **Ref. X**, **Ref. Y**, and **Ref. Angle** fields.

Reference Please refer to Section 9.1 for detailed locating configurations.

⊙ **Execute**

Specifies whether to execute the inspection function in the inspection process.

➤ **Always Execute**

Always execute the inspection function in Run mode.

➤ **Never Execute**

Never execute the inspection function in Run mode.

⊙ **Save**

Saves all modified parameters and values.

⊙ **Exit**

Leave the dialog box.

⊙ **Output Item**

➤ **Window**

Selects the output window for the total Judge result for the Edge Angle tool on the designated interface.

➤ **Item**

- 1) **Edge Angle (EAG)**: outputs the angle from two points on the edge found by the Edge Angle tool.
- 2) **Upper Edge Position X (X1)**: outputs the X coordinate of the first edge position encountered in the scanning direction between the two points found by the Edge Position tool.
- 3) **Upper Edge Position Y (Y1)**: outputs the Y coordinate of the first edge position encountered in the scanning direction between the two points found by the Edge Position tool.
- 4) **Lower Edge Position X (X2)**: outputs the X coordinate of the second edge position encountered in the scanning direction from the two points found by the Edge Position tool.
- 5) **Lower Edge Position Y (Y2)**: outputs the Y coordinate of the second edge position encountered in the scanning direction from the two points found by the Edge Position tool.
- 6) **Edge Angle ID**: outputs the ID of the inspection tool.
- 1) **Edge Angle (J) (EAG)**: outputs the selected standard Judge result found by the Edge Angle tool.

5.5 Edge Count

This tool searches for a defined type of edge using a fixed scanning path on a gray scale image. Any edge the system finds in the scanning path that satisfies the edge type and demonstrates enough difference in gray scale is recognized as one edge. The tool counts the total number of edges after completing the scan.

⊙ **Algorithmic Processing**

➤ Edge Position Scan Methods

Specifies the ROI. The ROI options provide differing edge scanning methods.

- ◆ When the ROI is Rectangle, Circle, Polygon, Ellipse, and Rotated Rect, you can define the scanning direction mode as left to right, right to left, downward, or upward.

- 1) When the scanning direction is left to right, and the edge type is light to dark, four edges are found in the following image.

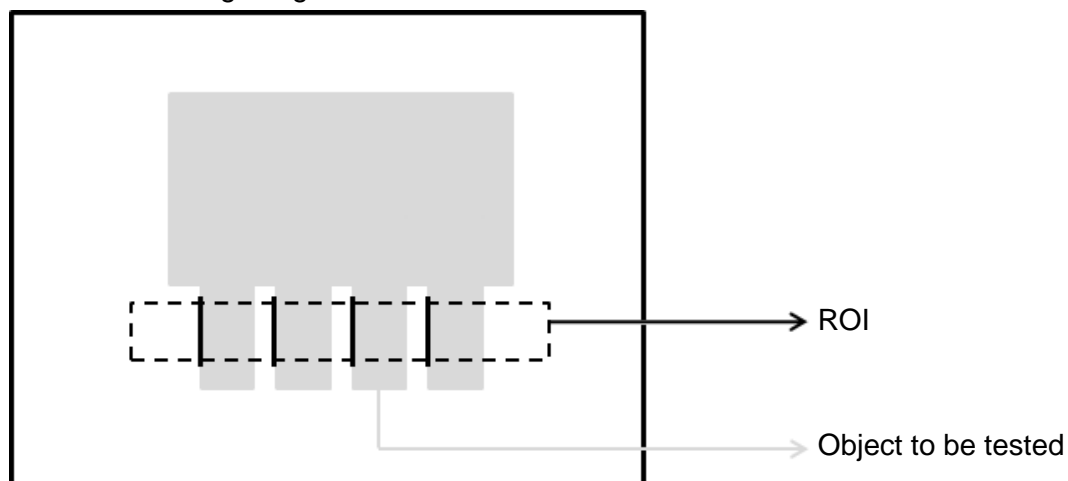

- 2) When the scanning direction is left to right, and the edge type is dark to light, four edges are found in the following image.

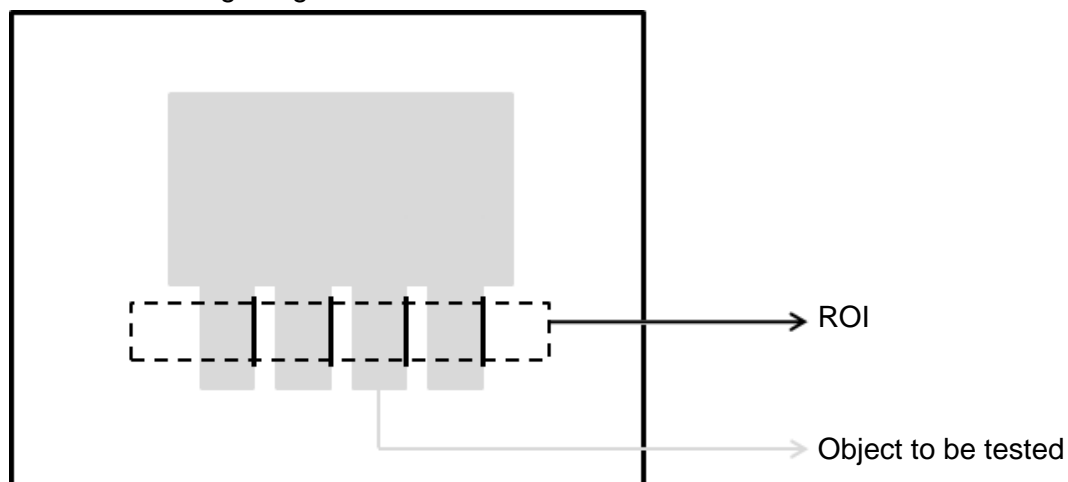

- 3) When the scanning direction is left to right with all edge types included, eight edges are found in the following image.

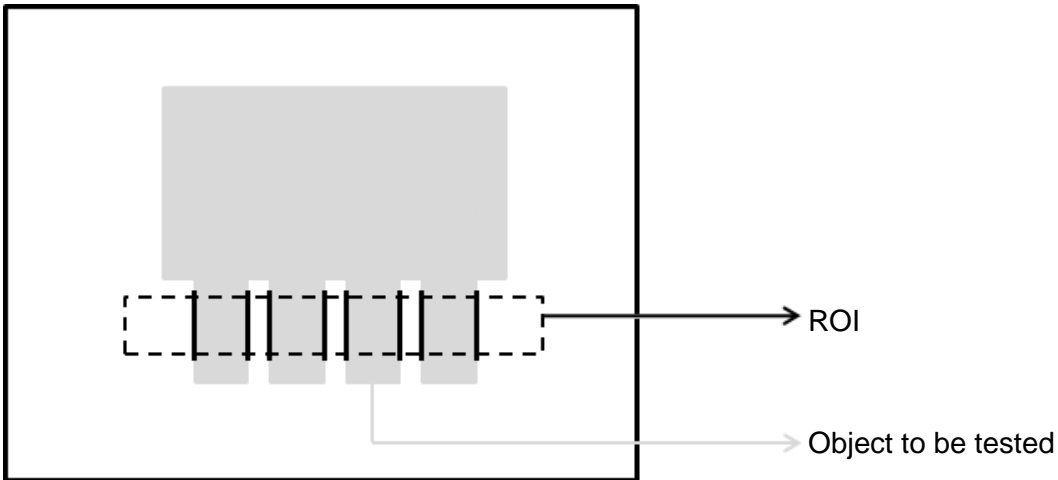

- ◆ When the ROI is Ring and Arc, the scanning direction can be clockwise or counterclockwise.

- 1) When the scanning direction is clockwise, and the edge type is light to dark, two edges are found in the following image.

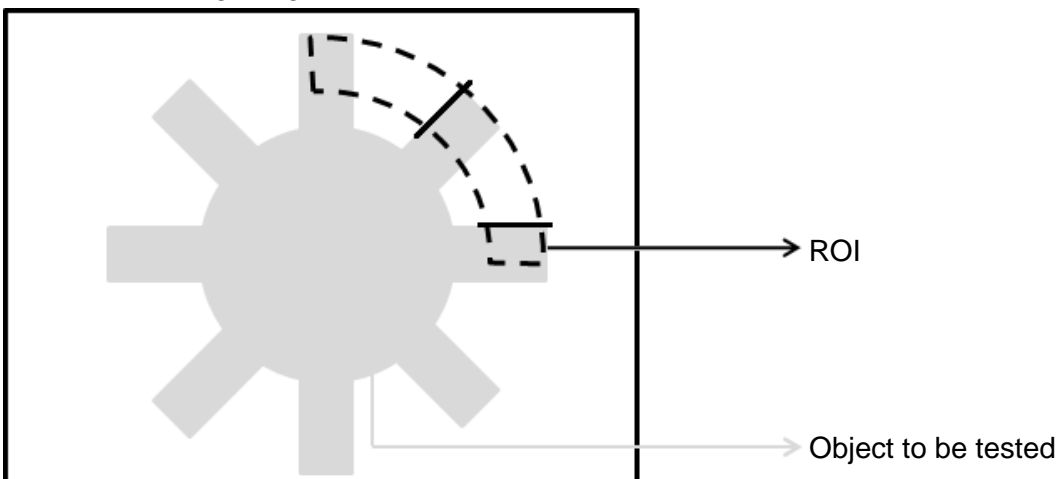

- 2) When the scanning direction is clockwise, and the edge type is dark to light, two edges are found in the following image.

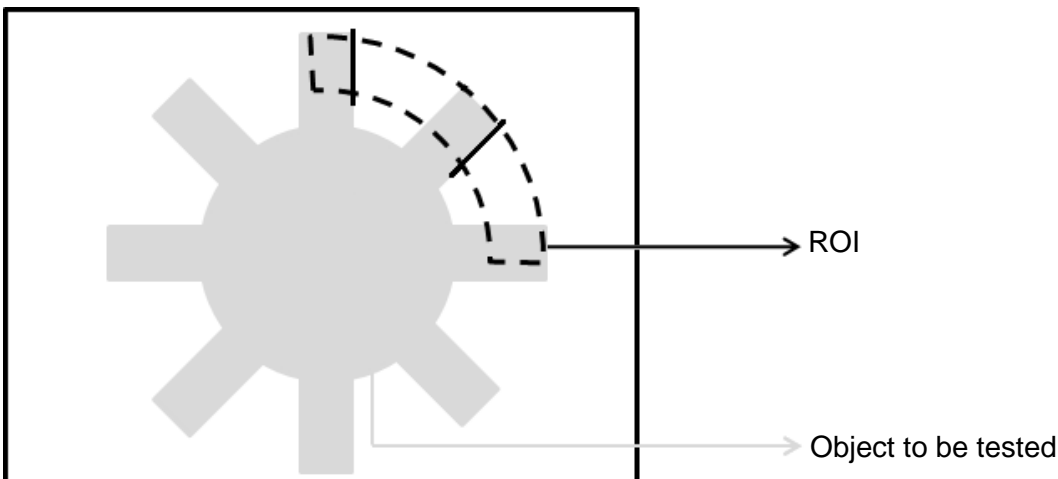

- 3) When the scanning direction is clockwise with all edge types included, five edges are found in the following image.

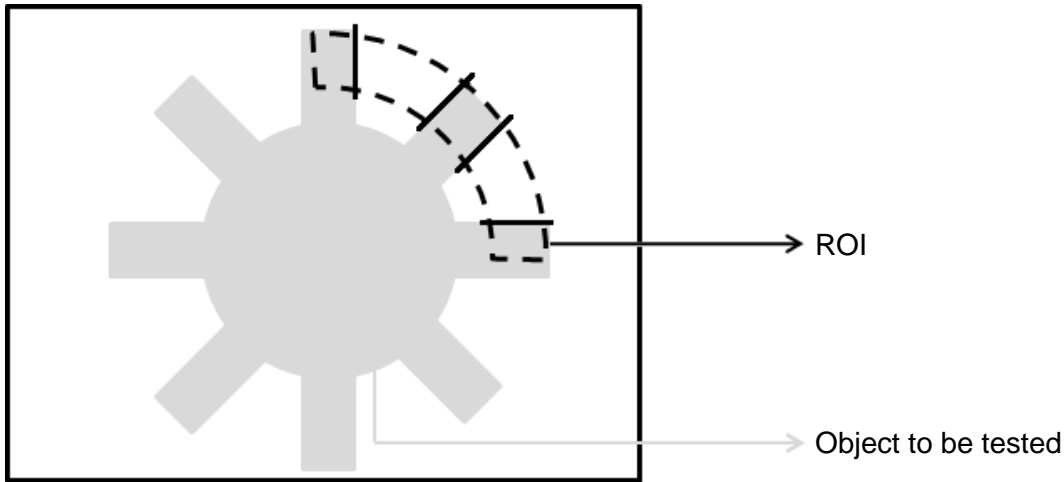

◎ Procedural Results

The Edge Count tool returns the following inspection results.

- Edge Count Number of Edges: outputs the total number of edges

◎ Edge Count dialog box

The following picture shows the Edge Count inspection tool dialog box.

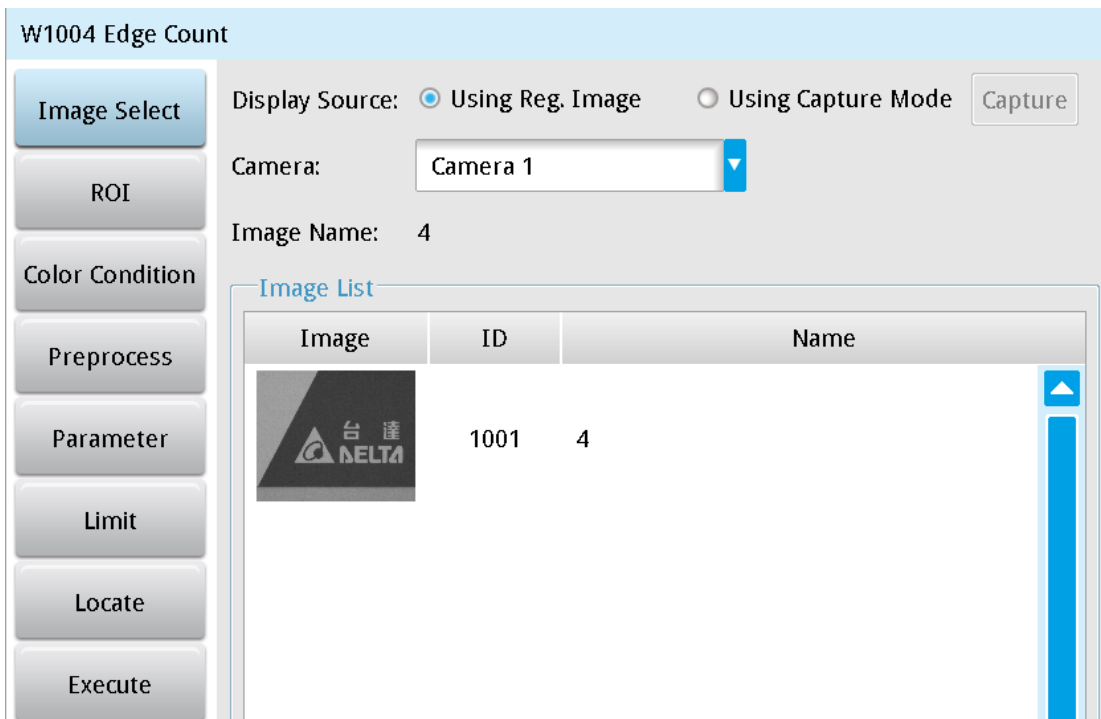

- **Image Select** (select Register Image)

Selects the image to be inspected from the register gallery. You can configure source cameras and inspect the image display source. When you select a different camera, the image table also switches to show the registered images acquired from that camera.

➤ **ROI** (configure detection region)

Specifies the inspection regions to be used in the inspection. The optional ROI shapes include Rectangle, Circle, Arc, Ellipse, Ring, Polygon, and Rotated Rect. The Polygon ROI supports up to 16 points. In addition, there are up to eight mask functions to ignore particular segments.

➤ **Color Condition**

Specifies the color processing for images from a color camera: Color to Binary, Color to Grayscale, RGB grayscale, R Grayscale, G Grayscale, and B Grayscale.

➤ **Preprocess**

Specifies the image processing to apply before inspections to enhance certain aspects of the image. Preprocessing methods include Binary, Dilation, Erosion, Average, Median, Laplacian, Sobel X, Sobel Y, Sobel XY, Brightness, Contrast, Shade, and Custom (filter). You can superimpose up to six methods or create a custom method by clicking **Custom**.

➤ **Parameter**

Adjusts the Edge Position inspection tool conditions.

Edge filter

Direction

When you select Ring or Arc for the ROI, you can then select Clockwise or Counterclockwise for the scanning direction. For other ROI shapes, you can select Left to Right, Right to Left, Upward, or Downward for the scanning direction.

Look For

Selects the search method: All Edges, Light to Dark, and Dark to Light.

Edge Strength

Specifies the threshold for the edge search (**Look For**), and you can fine-tune it between 0–100 based on the waveform displayed in the preview. When the peak is larger than the configured edge strength, **Look For** identifies the segment as an edge. As shown in the lower left picture, the system finds two edges when Edge Strength is set to 50. As shown in the lower right diagram, the system finds only one edge that is greater than the configured Edge Strength threshold of 70.

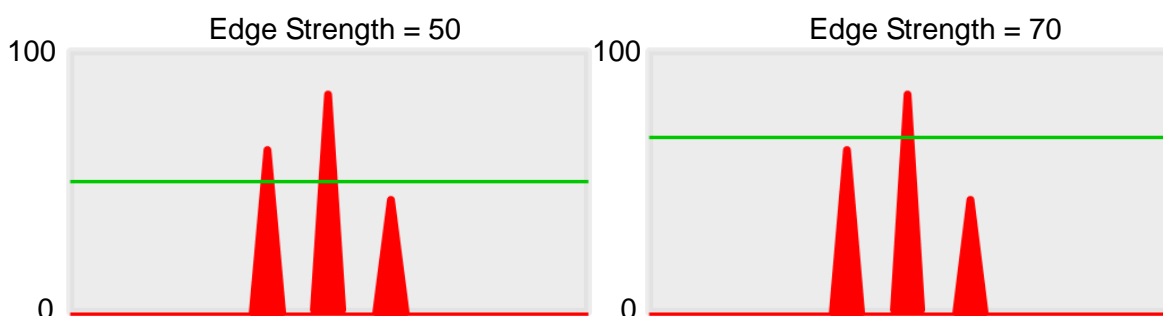

Lower

Use the Lower (limit) to filter small noise signals on the image, and the range is between 0–255. Peaks lower than the Lower value are filtered from the waveform. As shown in the lower left diagram, some noise appears when Lower is set to 0, but the noise is filtered out when Lower is set to 20.

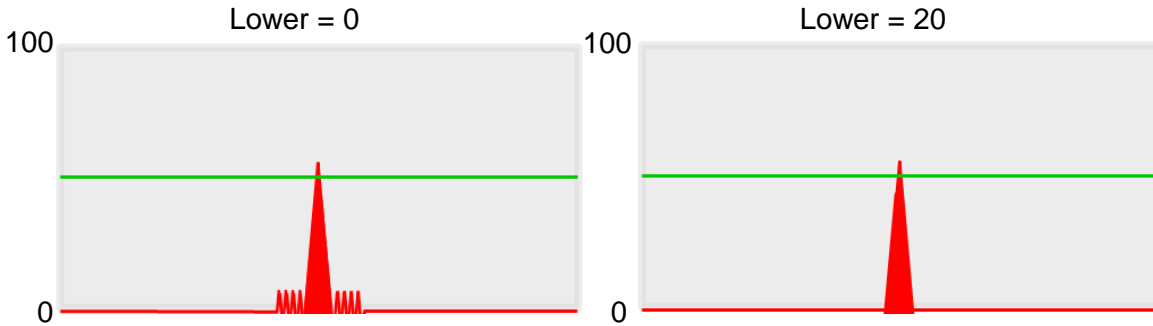

Smoothing

Sets the RGB Grayscale for edge calculations between 1–30. When you increase Smoothing, the slope of waveform changes, attenuating the effect caused by noise signals.

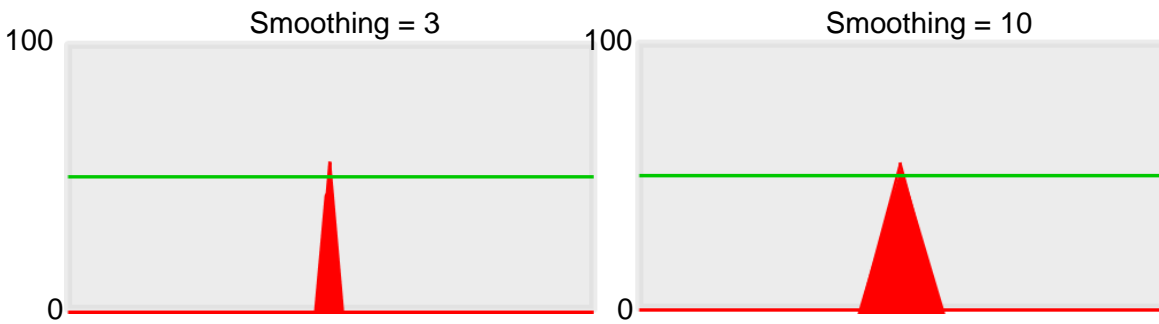

Angle

When the ROI is Ring or Arc, this sets the starting angle for the edge scan. The following pictures show starting angles of 0 and 45 degrees, respectively.

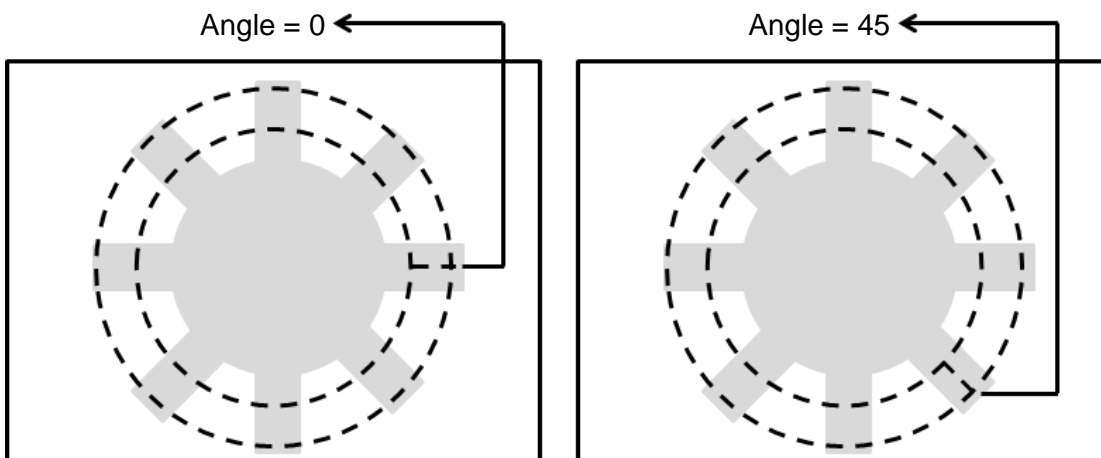

➤ **Limit**

After you complete the configurations, you can view the inspection results using register images through **Test Mode**. You can then configure the upper and lower limits in the Limit dialog box. The following items can be configured for the Edge Count tool.

Number of Edges: specifies the upper and lower limits for the number of edges.

➤ **Locate**

Specifies whether the inspection region follows an inspection result by adjusting its coordinates (X, Y) and Angles (Theta). The inspection tools you can use as a reference includes Shape, Blob, Edge Position and Edge Angle. As shown in the following diagram, specific marks (such as the cross on the object) can be used for the Locate function.

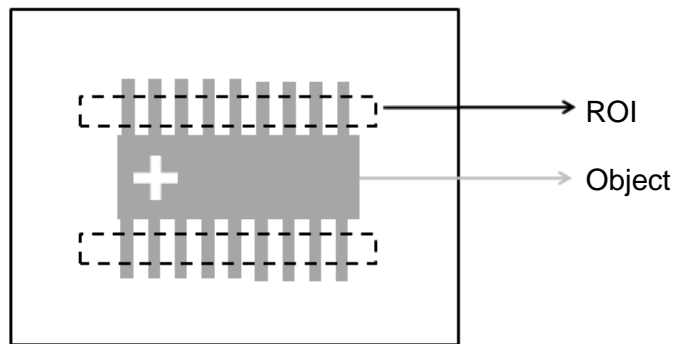

Locate Off

Locate On

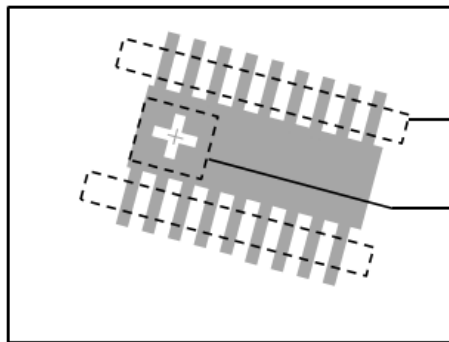
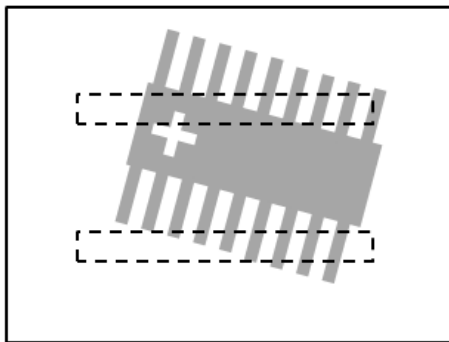

➤ Three tools are also provided in this item for quick configuration.

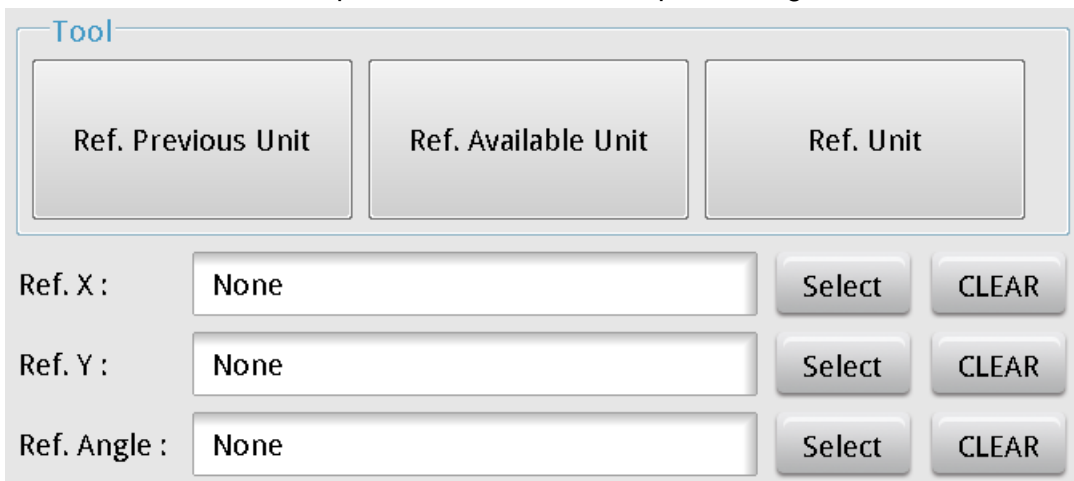

◆ Reference Previous Unit

Selects the nearest inspection tool that can provide reference for Locate, and automatically fills in the **Ref. X**, **Ref. Y**, and **Ref. Angle** fields.

◆ Reference Available Unit

Selects the nearest unit with Locate configured, and automatically fills in the **Ref. X**, **Ref. Y**, and **Ref. Angle** fields.

◆ Reference Unit

Arbitrarily selects an inspection tool that can provide locating reference, and automatically fills in the **Ref. X**, **Ref. Y**, and **Ref. Angle** fields.

 **Reference** Please refer to Section 9.1 for detailed Locate configurations.

⊙ Execute

Specifies whether to execute the inspection function in the inspection process.

➤ Always Execute

Always execute the inspection function in Run mode.

➤ Never Execute

Never execute the inspection function in Run mode.

⊙ Save

Saves all modified parameters and values.

⊙ Exit

Leaves the dialog box.

⊙ Output Item

➤ Window

Selects the output window for the total Judge result for the Edge Count tool on the designated interface.

➤ Item

- 1) **Number of Edges (N)**: outputs the total number of edges found by the Edge Count tool.
- 2) **Edge Count ID**: outputs the ID of the inspection tool.
- 3) **Number of Edges (J)**: outputs the logical (Judge) result of the total number of edges found by the Edge Count tool.

5.6 Edge Pitch

Edge Pitch is an enhanced function of the Edge Width tool. This tool measures multiple widths instead of just between two edges (as in Edge Width). The tool calculates the individual width, maximum width, minimum width, and average width.

⊙ **Algorithmic Processing**

➤ Edge Pitch Scan Methods

Specifies the type of ROI. The ROI options provide differing edge scanning methods.

- ◆ The two following examples are for ROIs other than Ring and Arc.

Scanning direction: Left to Right

Search method: All edges

Reference: 1

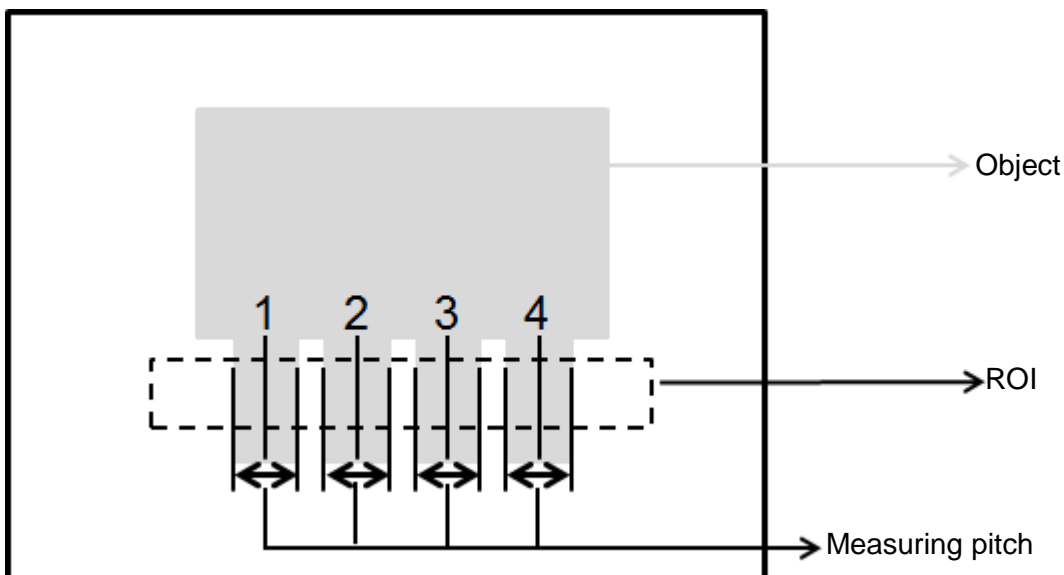

Scanning direction: Left to Right

Search method: Bright to dark

Reference: 1

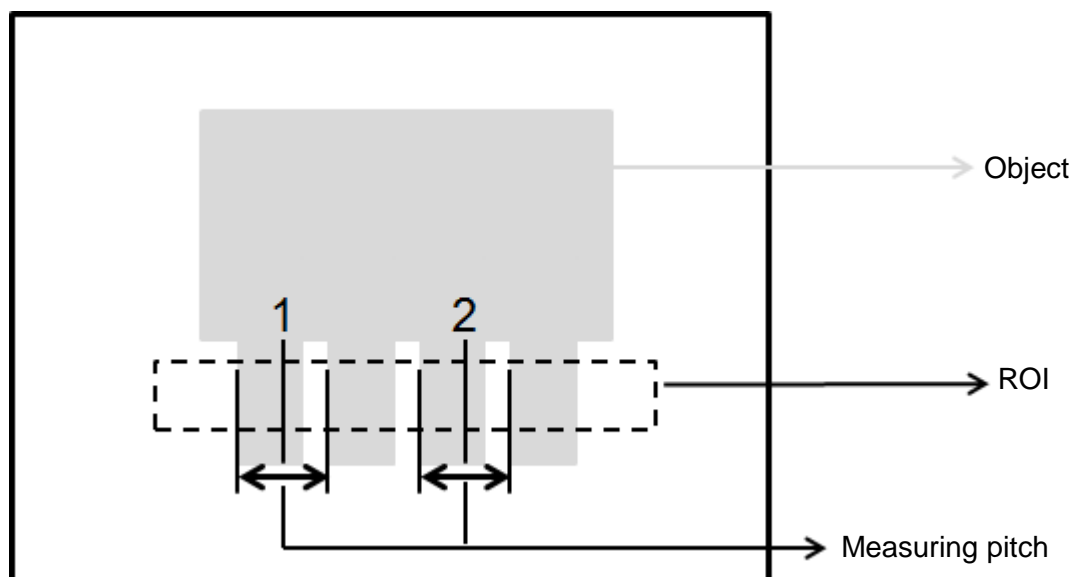

◆ The two following examples are for Ring and Arc ROIs.

Scanning direction: Clockwise

Search method: All edges

Angle: -45

Reference: 1

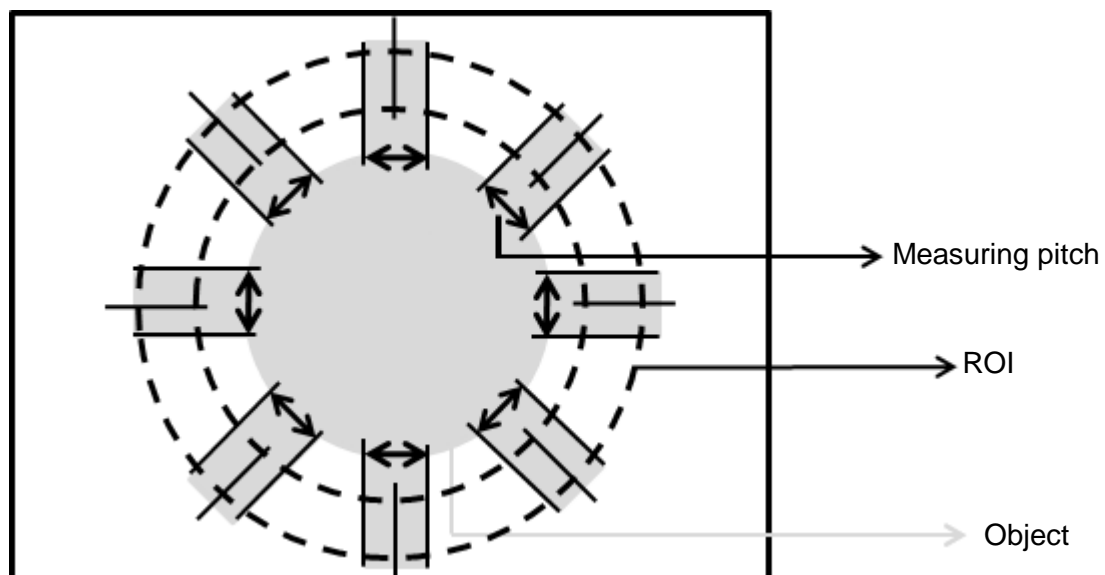

Scanning direction: Clockwise

Search method: All edges

Reference: 1

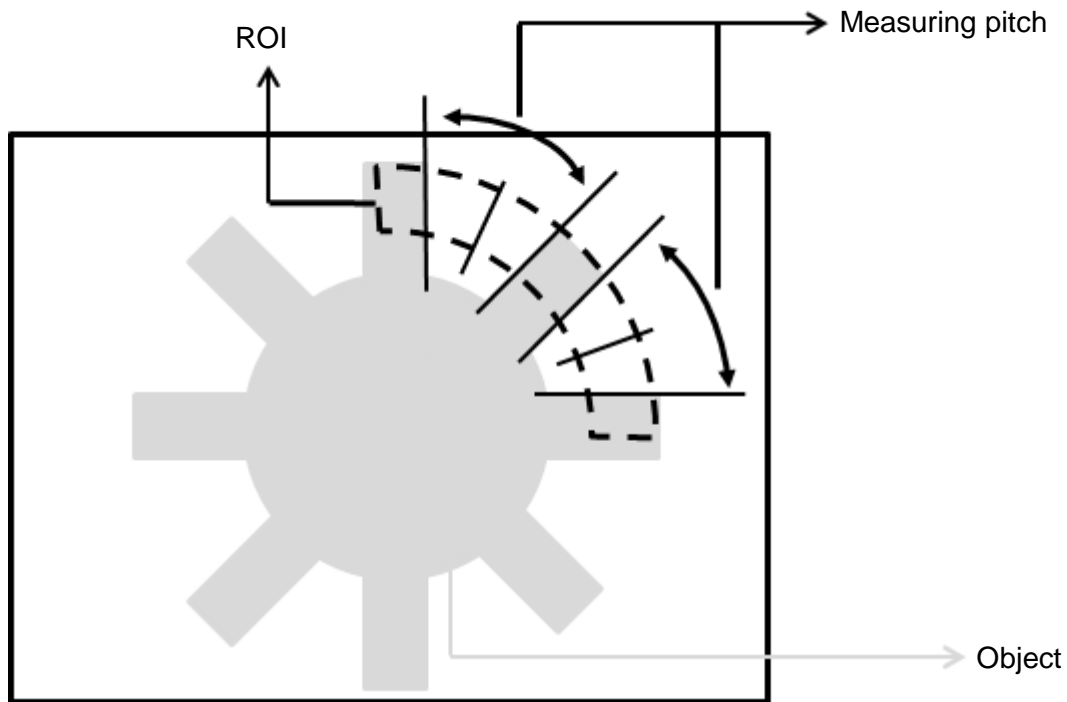

© Procedural Results

The Edge Pitch tool returns the following inspection results.

- Pitch Count: outputs the total number of pitches found by the Edge Pitch tool.
- Maximum Pitch: outputs the width data of the maximum pitch found among all pitch data by the Edge Pitch tool.
- Minimum Pitch: outputs the width data of the minimum pitch found among all pitch data by the Edge Pitch tool.
- Average Pitch: outputs the total average of all pitch data found by the Edge Pitch tool.

© **Example**

◆ The first example is for ROIs other than Ring and Arc; the second example is for Ring and Arc.

Scanning direction: Left to Right

Search method: All edges

Reference: 1

Inspection result: Pitch1 = 90, Pitch2 = 91, Pitch3 = 94, Pitch4 = 91

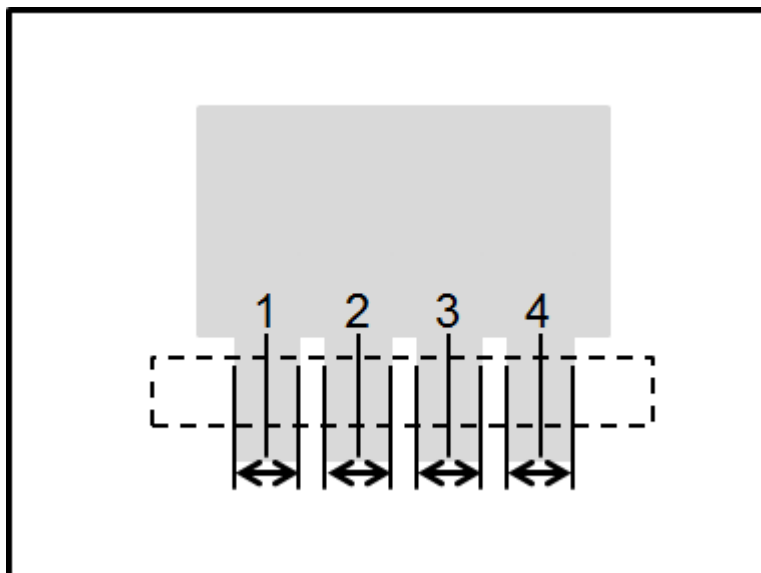

Scanning direction: Left to Right

Search method: All edges

Reference: 1

Inspection result: Pitch1 = 201, Pitch2 = 200

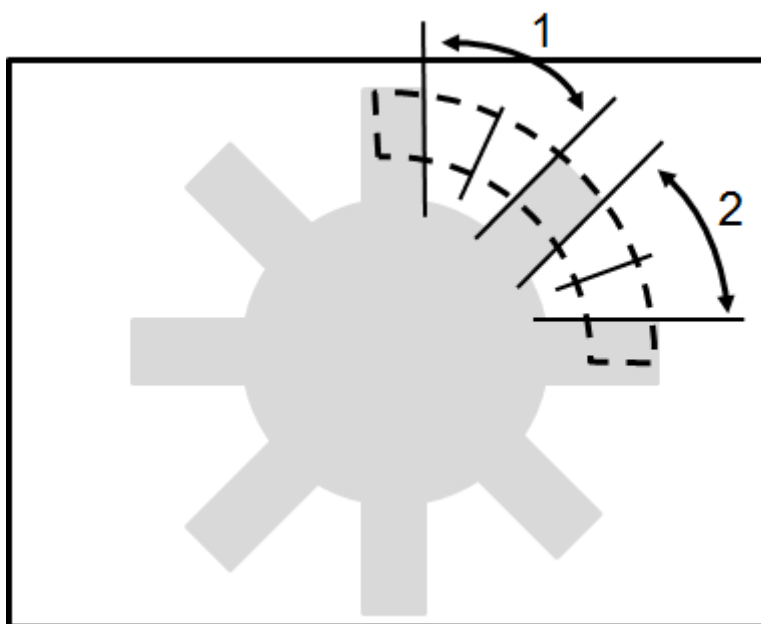

◎ Edge Pitch Dialog Box

The following picture shows the Edge Pitch inspection tool dialog box.

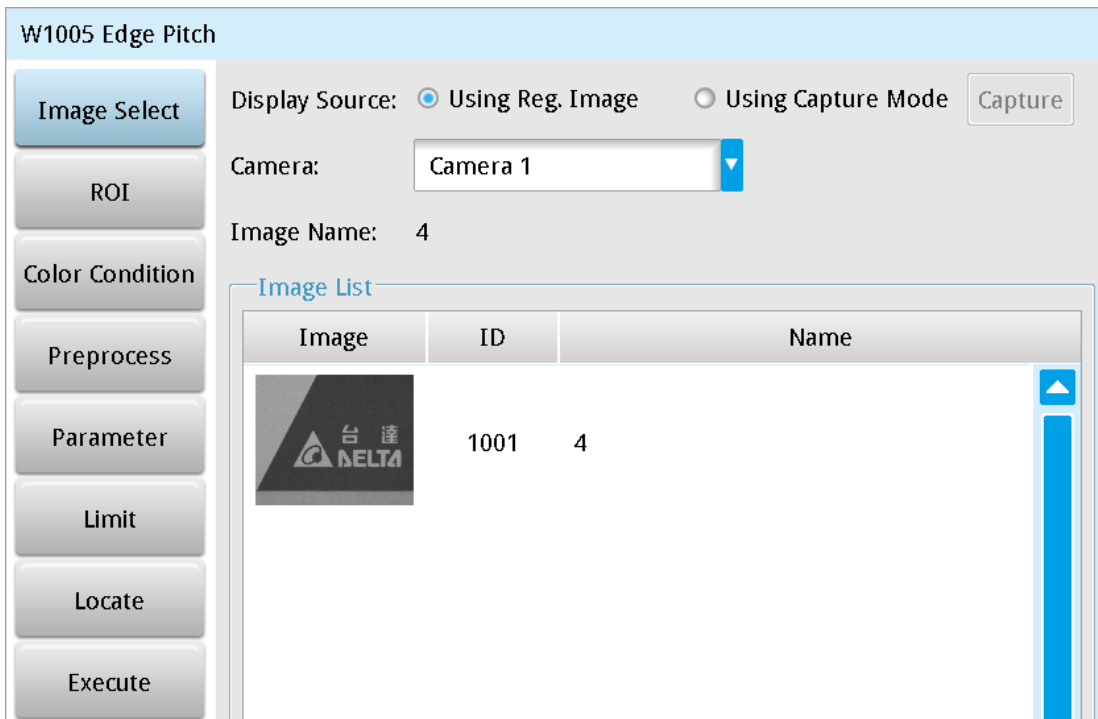

➤ Image Select (select Register Image)

Selects the image to be inspected from the register gallery. You can configure source cameras and inspect the image display source. When you select a different camera, the image table also switches to show the registered images acquired from that camera.

➤ ROI (configure detection region)

Specifies the inspection regions to be used in the inspection. The optional ROI shapes include Rectangle, Circle, Ellipse, Ring, Arc, Polygon, and Rotated Rect. The Polygon ROI supports up to 16 points. In addition, there are up to eight mask functions to ignore particular segments.

➤ Color Condition

Specifies the color processing for images from a color camera: Color to Binary, Color to Grayscale, RGB grayscale, R Grayscale, G Grayscale, and B Grayscale.

➤ Preprocess

Specifies the image processing to apply before inspections to enhance certain aspects of the image. Preprocessing methods include Binary, Dilation, Erosion, Average, Median, Laplacian, Sobel X, Sobel Y, Sobel XY, Brightness, Contrast, Shade, and Custom (filter). You can superimpose up to six methods or create a custom method by clicking **Custom**.

➤ Parameter

Adjusts the Edge Pitch inspection tool conditions.

Direction

When you select the Ring or Arc ROI, you can then select Clockwise or Counterclockwise for the scanning direction. For other ROI shapes, you can select Left to Right, Right to Left, Upward, or Downward for the scanning direction.

Look For

Specifies the search method: All Edges, Light to Dark, and Dark to Light.

Edge Strength

Specifies the threshold for the edge search (**Look For**), and you can fine-tune it between 0–100 based on the waveform displayed in the preview. When the peak is larger than the configured edge strength, **Look For** identifies the segment as an edge. As shown in the lower left picture, the system finds two edges when Edge Strength is set to 50. As shown in the lower right diagram, the system finds only one edge that is greater than the configured Edge Strength threshold of 70.



Lower

Use the Lower (limit) to filter small noise signals on the image, and the range is between 0–255. Peaks lower than the Lower value are filtered from the waveform. As shown in the lower left diagram, some noise appears when Lower is set to 0, but the noise is filtered out when Lower is set to 20.

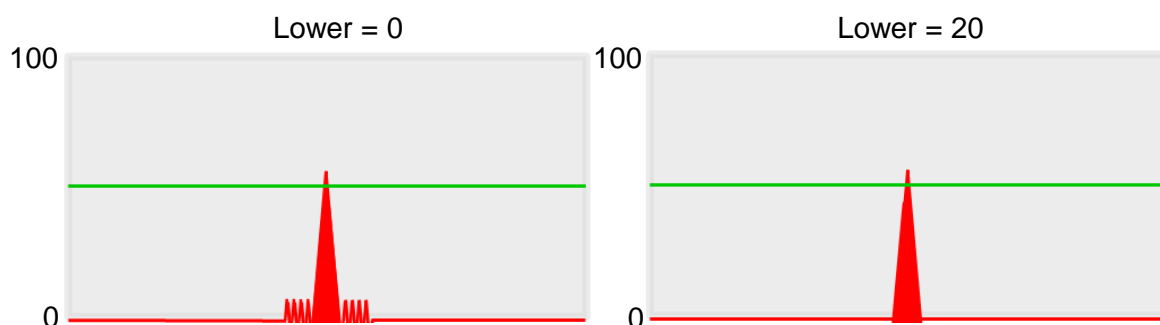

Smoothing

Sets the RGB Grayscale for edge calculations between 1–30. When you increase Smoothing, the slope of waveform changes, attenuating the effect caused by noise signals.

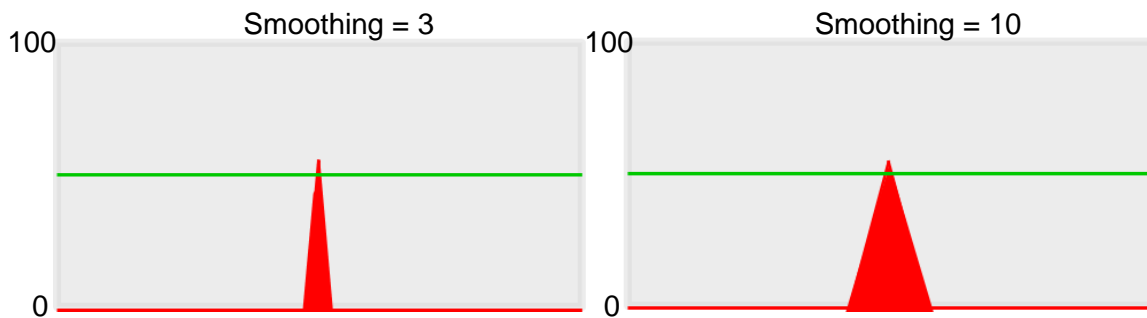

Angle

When the ROI is Ring or Arc, this sets the starting angle for the edge scan. The following pictures show starting angles of 0 and 45 degrees, respectively.

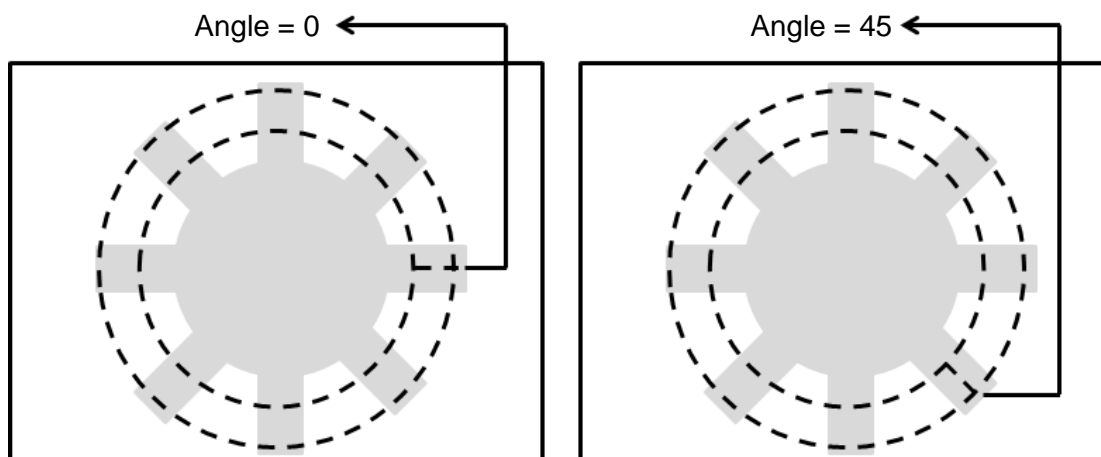

Reference

Output the Nth result when scanning multiple targets.

Pitch Upper

Specifies the threshold for retaining edge pitch. The edge pitch is kept if the measured value is below the upper pitch limit. Values exceeding the limit are discarded. The maximum value for the limit is 999.

Pitch Lower

Specifies the threshold for retaining edge pitch. The edge pitch is kept if the measured value is above the lower pitch limit. Values below the limit are discarded. The minimum value for the limit is 0.

Origin

The position of the origin (0, 0) in System Setting is displayed on the upper left corner of the screen. You can enter new coordinates to move the origin to the new coordinates.

➤ Limit

After you complete the configurations, you can view the inspection results using register images through **Test Mode**. You can then configure the upper and lower limits in the Limit dialog box. The following items can be configured for the Edge Pitch tool.

- **Pitch Count:** specifies the upper and lower limits for the number of pitch values.
- **Pitch:** specifies the upper and lower width limits of the assigned pitch for system reference.
- **Maximum Pitch:** specifies the upper and lower limits for the maximum pitch found from all pitch data.
- **Minimum Pitch:** specifies the upper and lower limits for the minimum pitch found from all pitch data.
- **Average Pitch:** specifies the upper and lower limits for the average pitch found from all pitch data.

➤ Locate

Specifies whether the inspection region follows an inspection result by adjusting its coordinates (X, Y) and Angles (Theta). The inspection tools you can use as a reference includes Shape, Blob, Edge Position and Edge Angle. As shown in the following diagram, specific marks (such as the cross on the object) can be used for the Locate function.

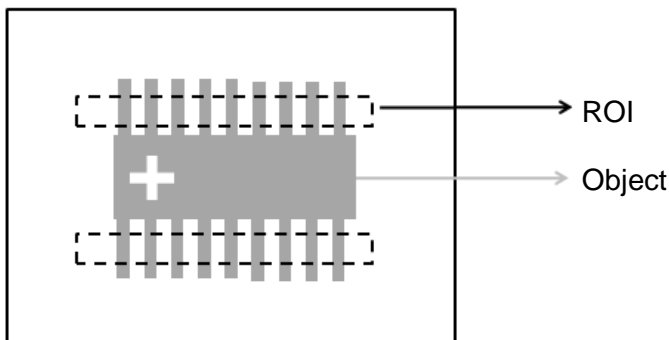

Locate Off

Locate On

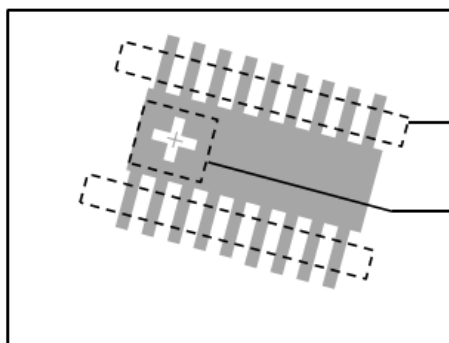
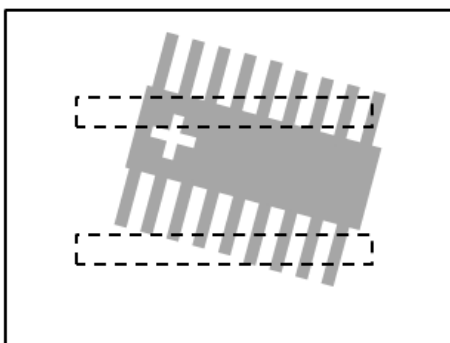

- Three tools are also provided in this item for quick configuration.

◆ Reference Previous Unit

Selects the nearest inspection tool that can provide reference for Locate, and automatically fills in the **Ref. X**, **Ref. Y**, and **Ref. Angle** fields.

◆ Reference Available Unit

Selects the nearest unit with Locate configured, and automatically fills in the **Ref. X**, **Ref. Y**, and **Ref. Angle** fields.

◆ Reference Unit

Arbitrarily selects an inspection tool that can provide locating reference, and automatically fills in the **Ref. X**, **Ref. Y**, and **Ref. Angle** fields.

 **Reference** Please refer to Section 9.1 for detailed Locate configurations.

⊙ Execute

Specifies whether to execute the inspection function in the inspection process.

➤ Always Execute

Always execute the inspection function in Run mode.

➤ Never Execute

Never execute the inspection function in Run mode.

⊙ Save

Saves all modified parameters and values.

⊙ Exit

Leaves the dialog box.

© Output Item

► Window

Selects the output window for the total Judge result for the Edge Pitch tool on the designated interface.

► Item

- 1) **Pitch Count (N)**: outputs the total number of pitches found by the Edge Pitch tool.
- 2) **Pitch (W)**: outputs the width data of the assigned pitch found among all pitch data by the Edge Pitch tool.
- 3) **Maximum Pitch (WH)**: outputs the width data of the maximum pitch found among all pitch data by the Edge Pitch tool.
- 4) **Minimum Pitch (WL)**: outputs the width data of the minimum pitch found among all pitch data by the Edge Pitch tool.
- 5) **Average Pitch (WA)**: outputs the total average of all pitch data found by the Edge Pitch tool.
- 6) **Pitch Center Position X (X)**: outputs the center position X coordinate of the assigned reference pitch found among all pitch data by the Edge Pitch tool.
- 7) **Pitch Center Position Y (Y)**: outputs the center position Y coordinate of the assigned reference pitch found among all pitch data by the Edge Pitch tool.
- 8) **Pitch Center Absolute Angle (AG)**: When you select the Ring or Arc ROI, Pitch Center Absolute Angle outputs the absolute angle of the assigned reference pitch found by the Edge Pitch tool.
- 9) **First Edge Position X (XS)**: outputs the first edge position X coordinate of the assigned reference pitch found among all pitch data by the Edge Pitch tool.
- 10) **First Edge Position Y (YS)**: outputs the first edge position Y coordinate of the assigned reference pitch found among all pitch data by the Edge Pitch tool.
- 11) **First Edge Absolute Angle (AGS)**: When you select the Ring or Arc ROI, First Edge Absolute Angle outputs the absolute angle of the first edge encountered from the assigned reference pitch found by the Edge Pitch tool.
- 12) **First Edge Relative Angle (RAS)**: When you select the Ring or Arc ROI, First Edge Relative Angle outputs the relative angle of the first edge encountered from the assigned reference pitch found by the Edge Pitch tool.
- 13) **Second Edge Position X (XE)**: outputs the second edge position X coordinate of the assigned reference pitch found among all pitch data by the Edge Pitch tool.
- 14) **Second Edge Position Y (YE)**: outputs the second edge position Y coordinate of the assigned reference pitch found among all pitch data by the Edge Pitch tool.
- 15) **Second Edge Absolute Angle (AGE)**: When Ring and Arc ROIs are selected, Second Edge Absolute Angle outputs the absolute angle of the second edge encountered from the assigned reference pitch found by the Edge Pitch tool.
- 16) **Second Edge Relative Angle (RAE)**: When Ring and Arc ROIs are selected, Second Edge Relative Angle outputs the relative angle of the second edge encountered from the assigned reference pitch found by the Edge Pitch tool.
- 17) **Edge Pitch ID**: outputs the ID of the inspection tool.

- 18) **Pitch Count (J) (N)**: outputs the logical (Judge) result of the pitch count obtained by the Edge Pitch tool.
- 19) **Pitch (J) (W)**: outputs the logical (Judge) result of the assigned reference pitch widths obtained by the Edge Pitch tool.
- 20) **Maximum Pitch (J) (WH)**: outputs the logical (Judge) result of the maximum assigned reference pitch width obtained by the Edge Pitch tool.
- 21) **Minimum Pitch (J) (WL)**: outputs the logical (Judge) result of the minimum assigned reference pitch width obtained by the Edge Pitch tool.
- 22) **Average Pitch (J) (WA)**: outputs the logical (Judge) result of the average assigned reference pitch width obtained by the Edge Pitch tool.

5.7 Edge Position

This tool searches for edges formed by brightness differences on a gray scale image. You can specify the search region and the horizontal or vertical scanning method. When the tool finds image segments of greater brightness differences, the tool recognizes the region as an edge; otherwise the tool is unlikely to detect effective edges in regions of smaller brightness differences.

◎ **Algorithmic Processing**

➤ Edge Position Scan Methods

Selects the ROI. The ROI options provide differing edge scanning methods.

◆ The two following examples are for ROIs other than Ring and Arc.

Scanning direction: Left to Right

Search method: Bright to dark

Reference: 1

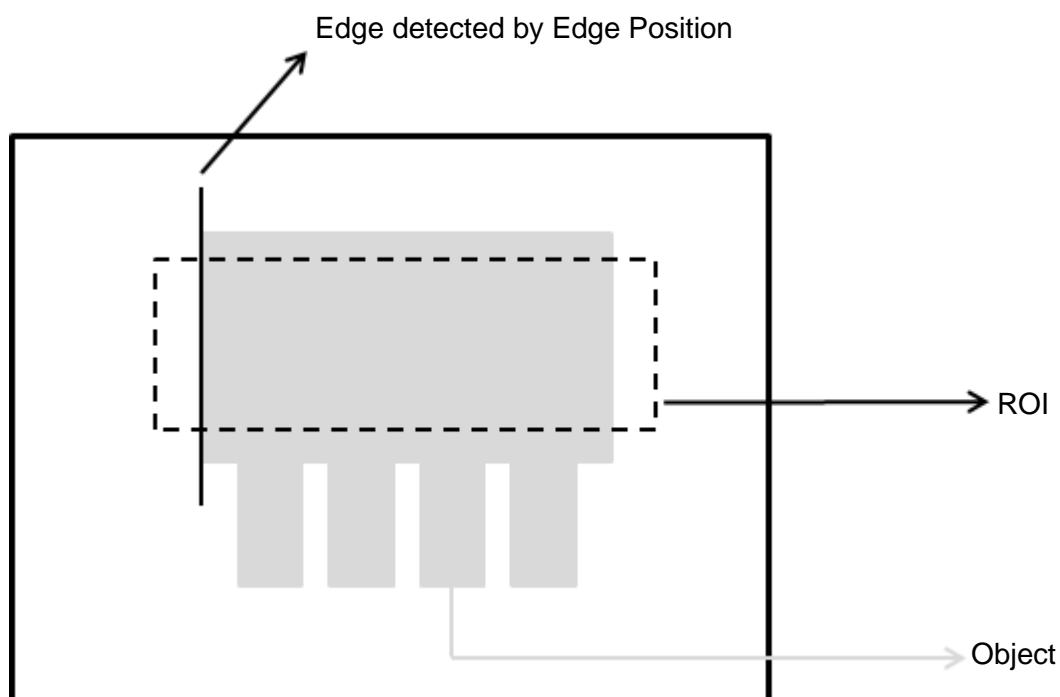

Scanning direction: Left to Right

Search method: Bright to dark

Reference: 2

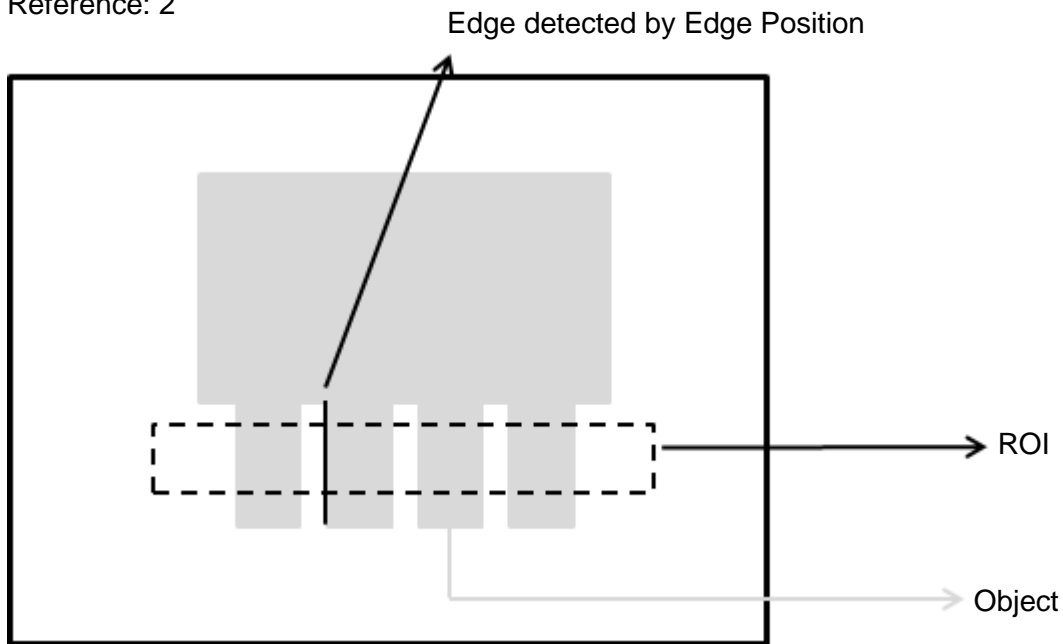

◆ The two following examples are for Ring and Arc ROIs.

Scanning direction: Clockwise

Search method: Bright to dark

Angle: 0

Reference: 1

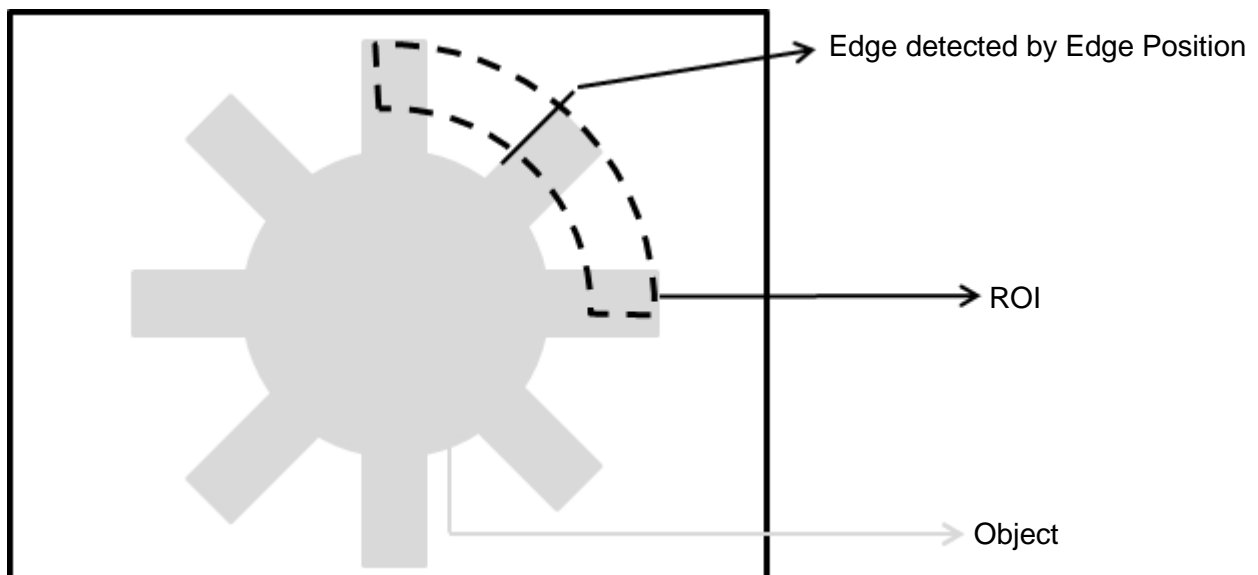

Scanning direction: Counterclockwise

Search method: Bright to dark

Angle: 0

Reference: 1

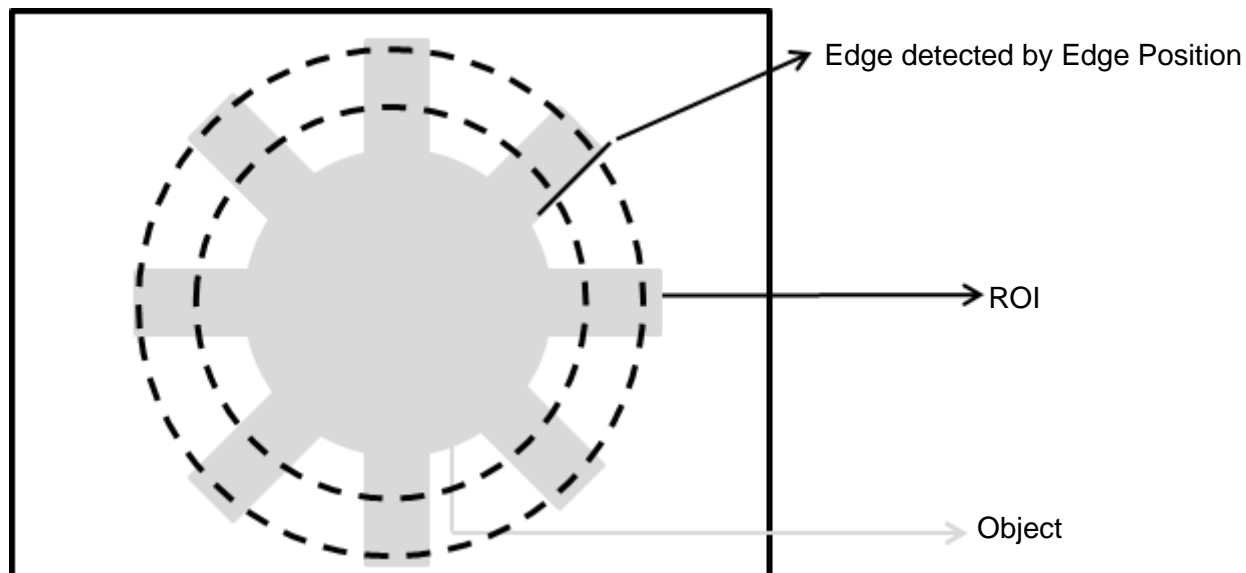

© Procedural Results

The Edge Position tool returns the following inspection results.

- Edge Position X: outputs the X coordinate of the edge found by the Edge Position tool.
- Edge Position Y: outputs the Y coordinate of the edge found by the Edge Position tool.
- Edge Absolute Angle: if you select the Ring or Arc ROI, the Edge Absolute Angle function outputs the absolute angle of the edge found by the Edge Pitch tool.
- Edge Relative Angle: if you select the Ring or Arc ROI, the Edge Relative Angle function outputs the relative angle of the edge found by the Edge Pitch tool.

◎ **Example**

◆ For ROIs other than Ring and Arc

Scanning direction: Left to Right

Search method: Bright to dark

Reference: 1

Inspection result: X coordinate is 200

X coordinate: 200

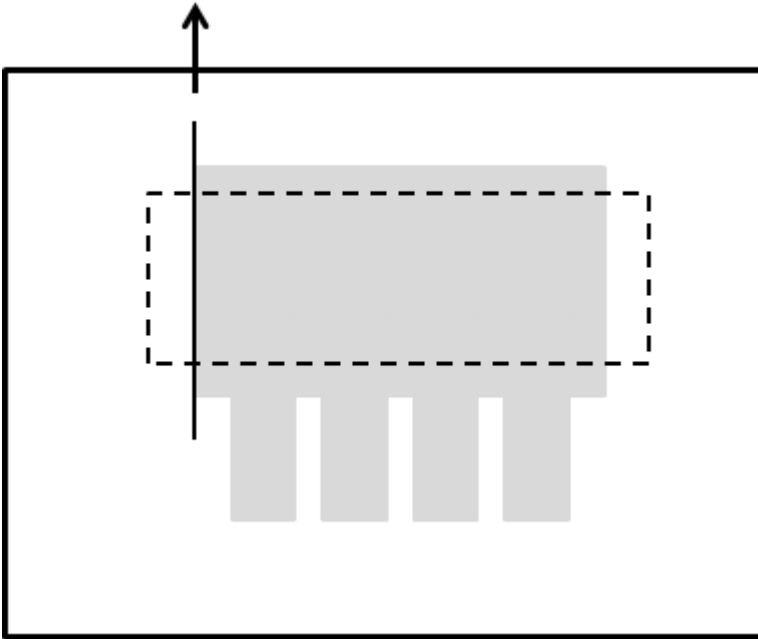

◆ For Ring and Arc ROIs

Scanning direction: Clockwise

Search method: Bright to dark

Angle: 0

Reference: 1

Inspection result: The absolute angle of the edge is 45 degrees.

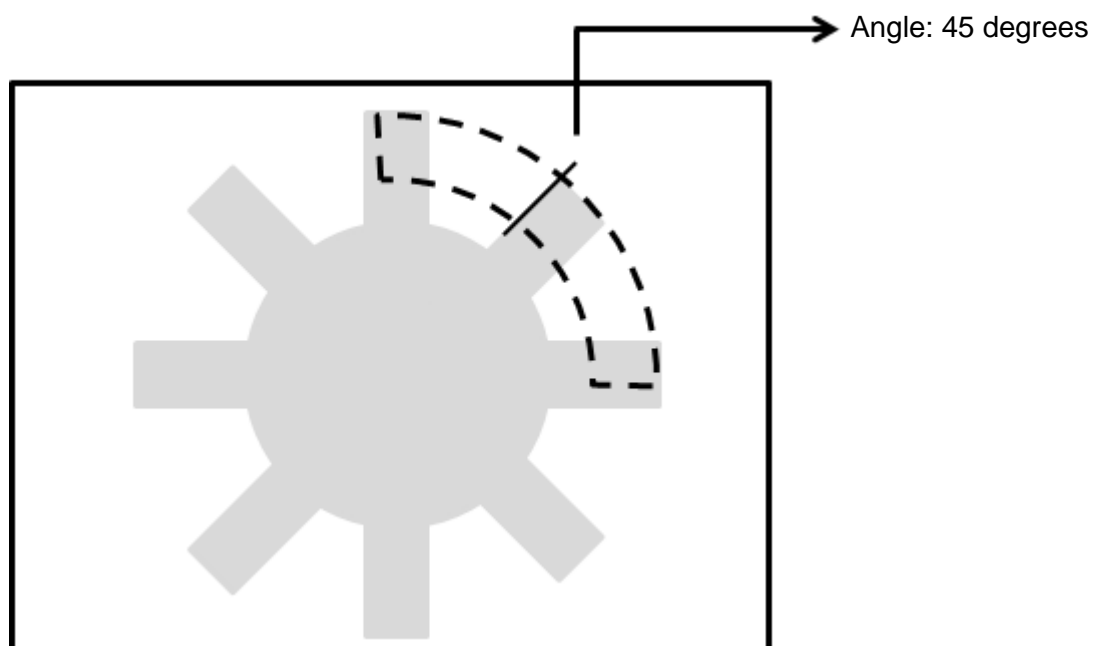

◎ Edge Position dialog box

The following picture shows the Edge Position inspection tool dialog box.

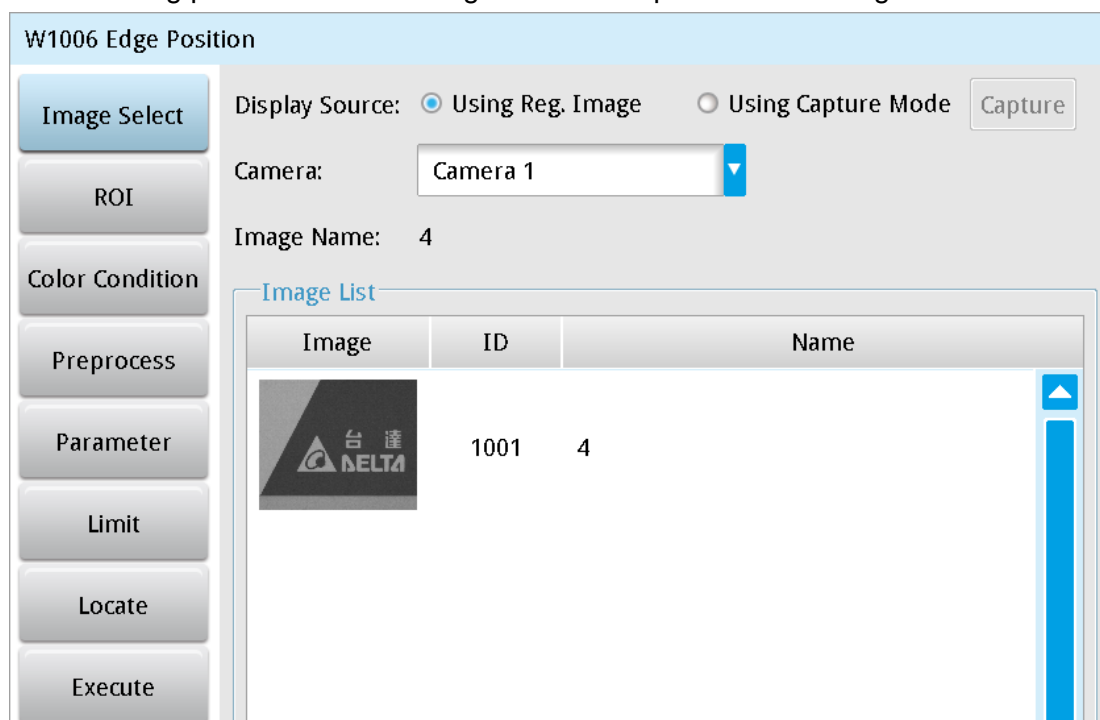

➤ **Image Select** (select Register Image)

Selects the image to be inspected from the register gallery. You can configure source cameras and inspect the image display source. When you select a different camera, the image table also switches to show the registered images acquired from that camera.

➤ **ROI** (configure detection region of interest)

Specifies the inspection regions to be used in the inspection. The optional ROI shapes include Rectangle, Circle, Ellipse, Ring, Arc, Polygon, and Rotated Rect. The Polygon ROI supports up to 16 points. In addition, there are up to eight mask functions to ignore particular segments.

➤ **Color Condition**

Selects the color processing for images from a color camera: Color to Binary, Color to Grayscale, RGB grayscale, R Grayscale, G Grayscale, and B Grayscale.

➤ **Preprocess**

Specifies the image processing to apply before inspections to enhance certain aspects of the image. Preprocessing methods include Binary, Dilation, Erosion, Average, Median, Laplacian, Sobel X, Sobel Y, Sobel XY, Brightness, Contrast, Shade, and Custom (filter). You can superimpose up to six methods or create a custom method by clicking **Custom**.

➤ **Parameters**

Adjusts the Edge Position inspection tool conditions.

Direction

When you select Ring or Arc for the ROI, you can then select Clockwise or Counterclockwise for the scanning direction. For other ROI shapes, you can select Left to Right, Right to Left, Upward, or Downward for the scanning direction.

Look For

Selects the search method: All Edges, Light to Dark, and Dark to Light.

Edge Strength

Specifies the threshold for the edge search (**Look For**), and you can fine-tune it between 0–100 based on the waveform displayed in the preview. When the peak is larger than the configured edge strength, **Look For** identifies the segment as an edge. As shown in the lower left picture, the system finds two edges when Edge Strength is set to 50. As shown in the lower right diagram, the system finds only one edge that is greater than the configured Edge Strength threshold of 70.

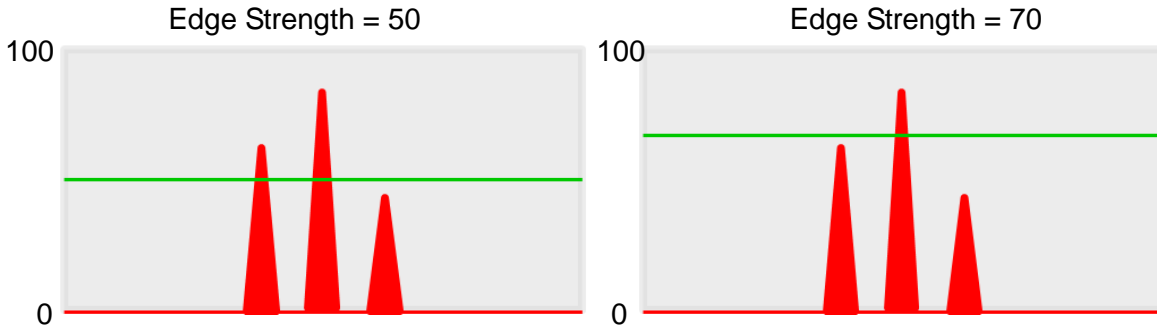

Lower

Use the Lower (limit) to filter small noise signals on the image, and the range is between 0–255. Peaks lower than the Lower value are filtered from the waveform. As shown in the lower left diagram, some noise appears when Lower is set to 0, but the noise is filtered out when Lower is set to 20.

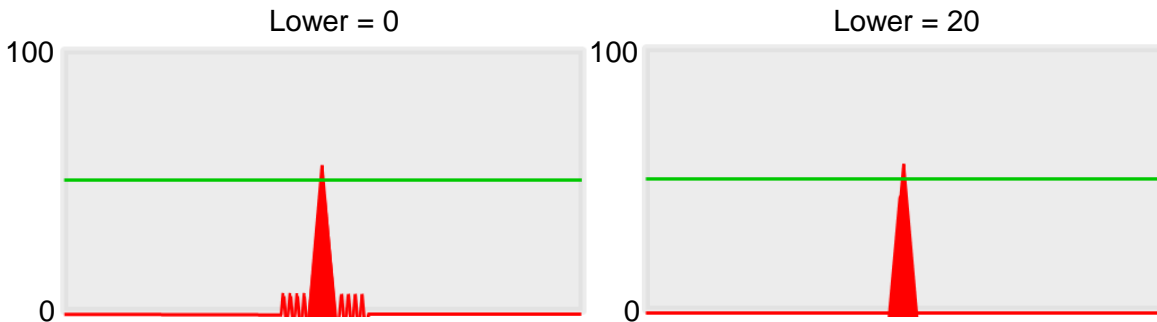

Smoothing

Sets the RGB Grayscale for edge calculations between 1–30. When you increase Smoothing, the slope of waveform changes, attenuating the effect caused by noise signals.

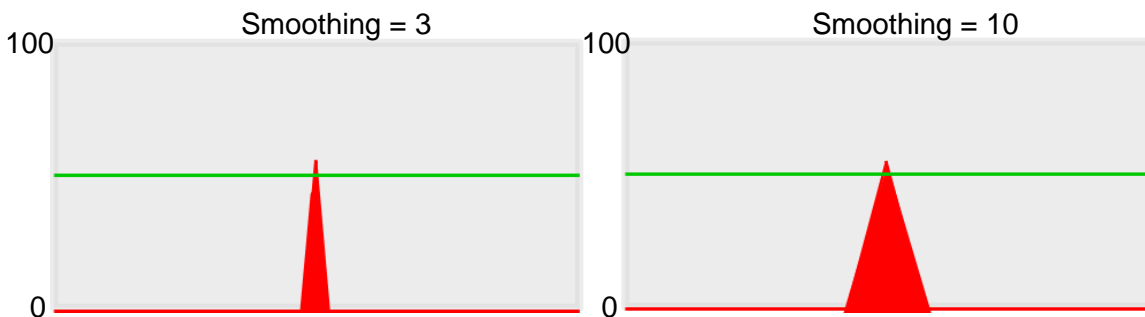

Angle

When the ROI is Ring or Arc, this sets the starting angle for the edge scan. The following pictures show starting angles of 0 and 45 degrees, respectively.

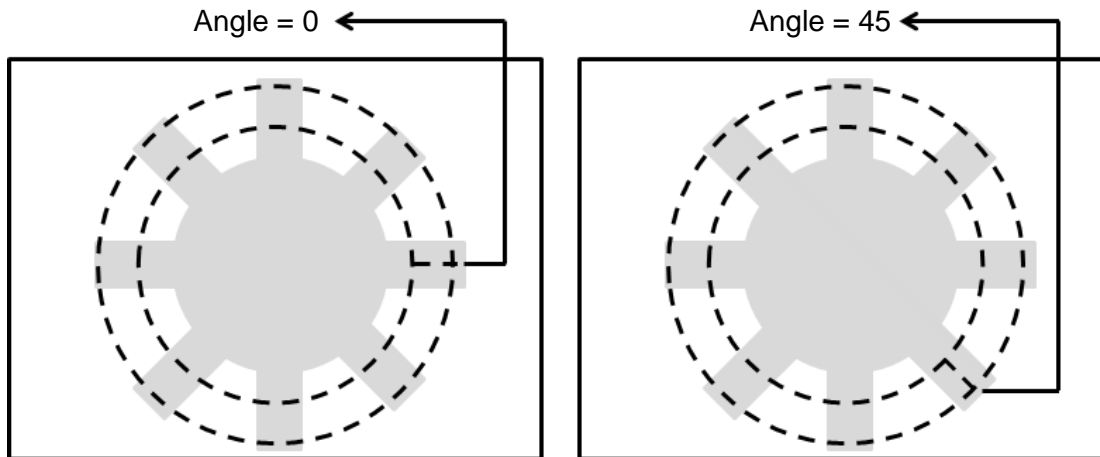

Reference

Output the Nth result when scanning multiple targets.

Origin

The position of the origin (0, 0) in System Setting is displayed on the upper left corner of the screen. You can enter new coordinates to move the origin to the new coordinates.

➤ Limit

After you complete the configurations, you can view the inspection results using register images through **Test Mode**. You can then configure the upper and lower limits in the Limit dialog box. The following items can be configured for the Edge Position tool.

- **Edge Position X:** specifies the upper and lower X coordinate limits of edges.
- **Edge Position Y:** specifies the upper and lower Y coordinate limits of edges.
- **Edge Absolute Angle:** If you select Ring or Arc for ROI, there is an effective absolute edge angle. This value specifies the upper and lower limits for the angle.

► Locate

Specifies whether the inspection region follows an inspection result by adjusting its coordinates (X, Y) and Angles (Theta). The inspection tools you can use as a reference includes Shape, Blob, Edge Position and Edge Angle. As shown in the following diagram, specific marks (such as the cross on the object) can be used for the Locate function.

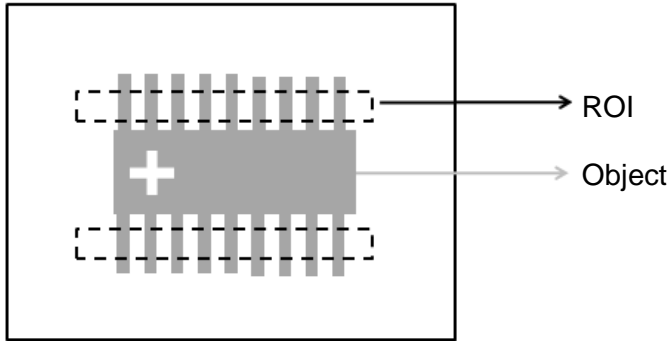

Locate Off

Locate On

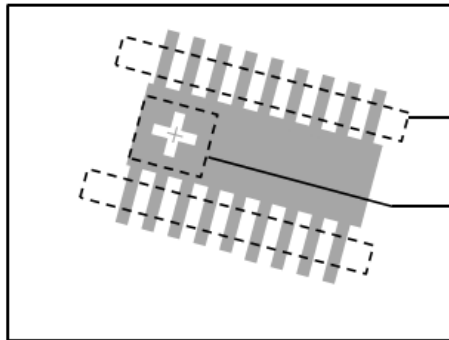
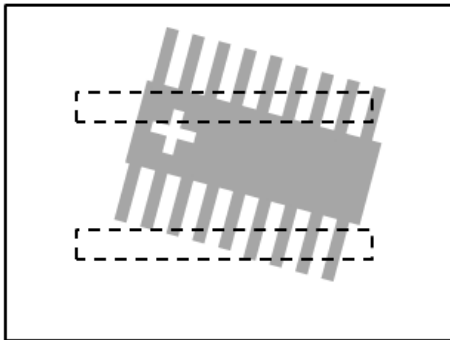

► Three tools are also provided in this item for quick configuration.

Tool

Ref. Previous Unit	Ref. Available Unit	Ref. Unit
--------------------	---------------------	-----------

Ref. X :

Ref. Y :

Ref. Angle :

◆ Reference Previous Unit

Selects the nearest inspection tool that can provide reference for Locate, and automatically fills in the **Ref. X**, **Ref. Y**, and **Ref. Angle** fields.

◆ Reference Available Unit

Selects the nearest unit with Locate configured, and automatically fills in the **Ref. X**, **Ref. Y**, and **Ref. Angle** fields.

◆ Reference Unit

Arbitrarily selects an inspection tool that can provide locating reference, and automatically fills in the **Ref. X**, **Ref. Y**, and **Ref. Angle** fields.

 **Reference** Please refer to Section 9.1 for detailed Locate configurations.

⊙ Execute

Specifies whether to execute the inspection function in the inspection process.

➤ Always Execute

Always execute the inspection function in Run mode.

➤ Never Execute

Never execute the inspection function in Run mode.

⊙ Save

Saves all modified parameters and values.

⊙ Exit

Leaves the dialog box.

⊙ Output Item

➤ Window

Selects the output window for the total Judge result for the Edge Position tool on the designated interface.

➤ Item

- 1) **Number of Edges (N)**: outputs the total number of edges found by the Edge Position tool.
- 2) **Edge Position X (X)**: outputs the X coordinate of the edge found by the Edge Position tool.
- 3) **Edge Position Y (Y)**: outputs the Y coordinate of the edge found by the Edge Position tool.
- 4) **Edge Absolute Angle (AG)**: when you select the Ring or Arc ROI, Edge Absolute Angle outputs the absolute angle of the edge found by the Edge Pitch tool.
- 5) **Edge Relative Angle (RA)**: when you select the Ring or Arc, Edge Relative Angle outputs the relative angle of the edge found by the Edge Pitch tool.
- 6) **Edge Position ID**: outputs the ID of the inspection tool.
- 7) **Edge Position X (J) (X)**: outputs the logical (Judge) result of the X coordinates of the edges found by the Edge Position tool.
- 8) **Edge Position Y (J) (Y)**: outputs the logical (Judge) result of the Y coordinates of the edges found by the Edge Position tool.
- 9) **Edge Absolute Angle (J) (AG)**: when you select the Ring or Arc ROI, Edge Absolute Angle (J) outputs the logical (Judge) result of the absolute edge angle found by the Edge Position tool.

5.8 Edge Width

This tool searches for multiple edges formed by the brightness differences on a gray scale images and calculates the edge widths. You specify the search region and the horizontal or vertical scanning method, or the outer or inner edge detection. When the tool detects image segments of larger brightness differences, the tool recognizes the region as an edge and looks for the edge pitch; otherwise, the tool is unlikely to detect effective widths in regions of smaller brightness differences or in regions consisting of only one edge.

◎ **Algorithmic Processing**

➤ **Edge Width Scan Methods**

Selects the ROI. The ROI options provide differing edge scanning methods.

◆ The three following examples are for ROIs other than Ring and Arc.

Scanning direction: Horizontal

Search method: All edges

Measure method: Out to in

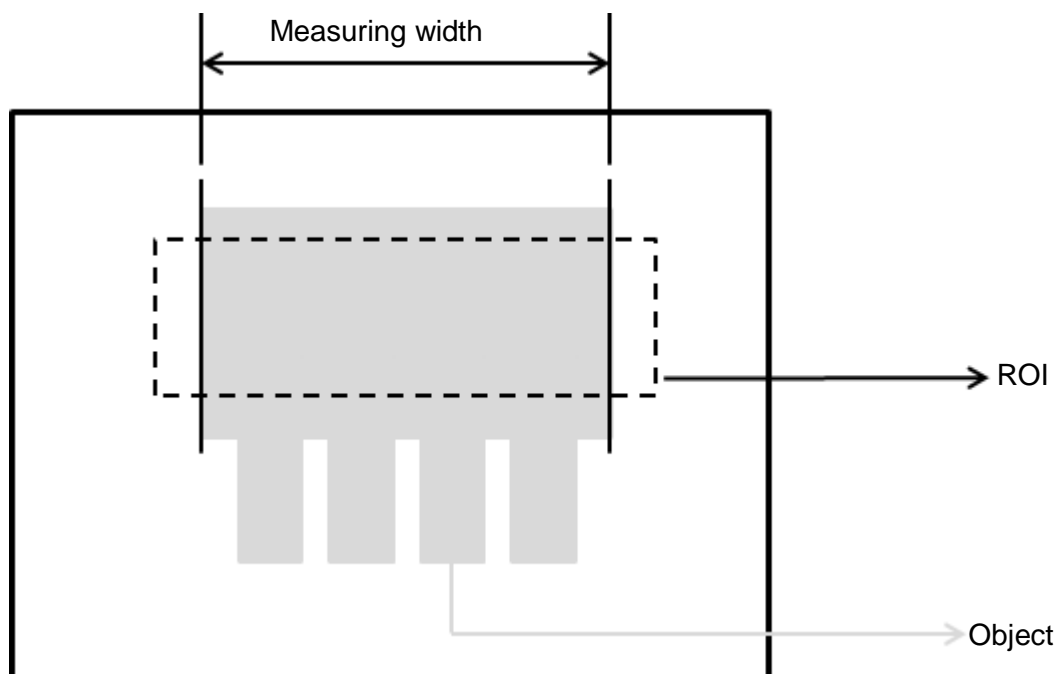

Scanning direction: Horizontal

Search method: All edges

Measure method: Inside-out

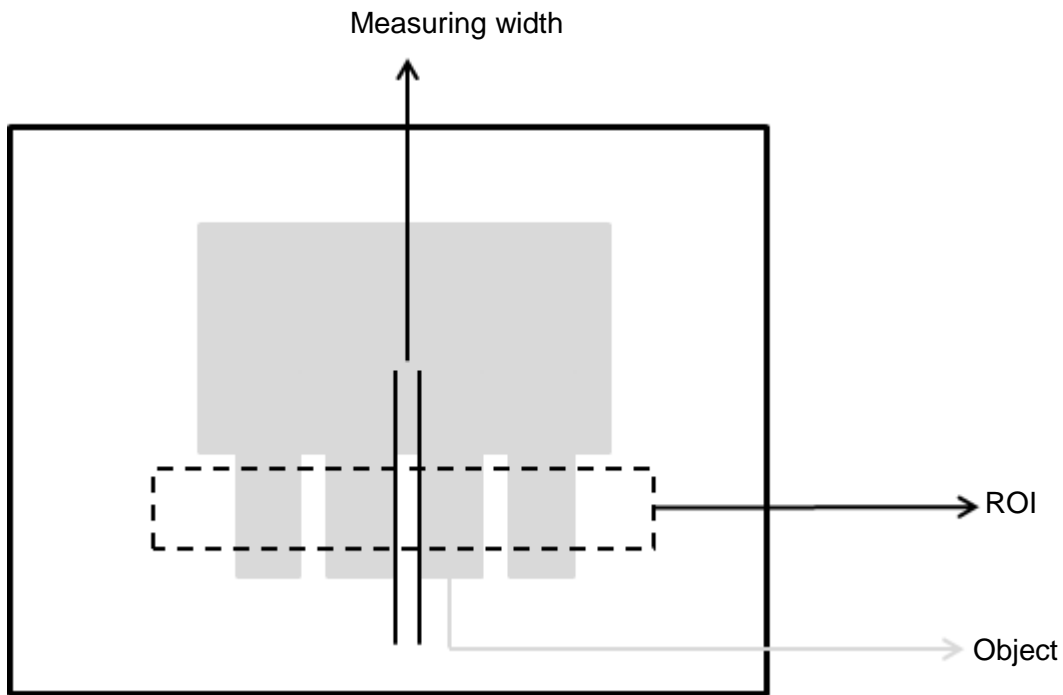

Scanning direction: Horizontal

Search method: Dark to bright

Measure method: Outside-in

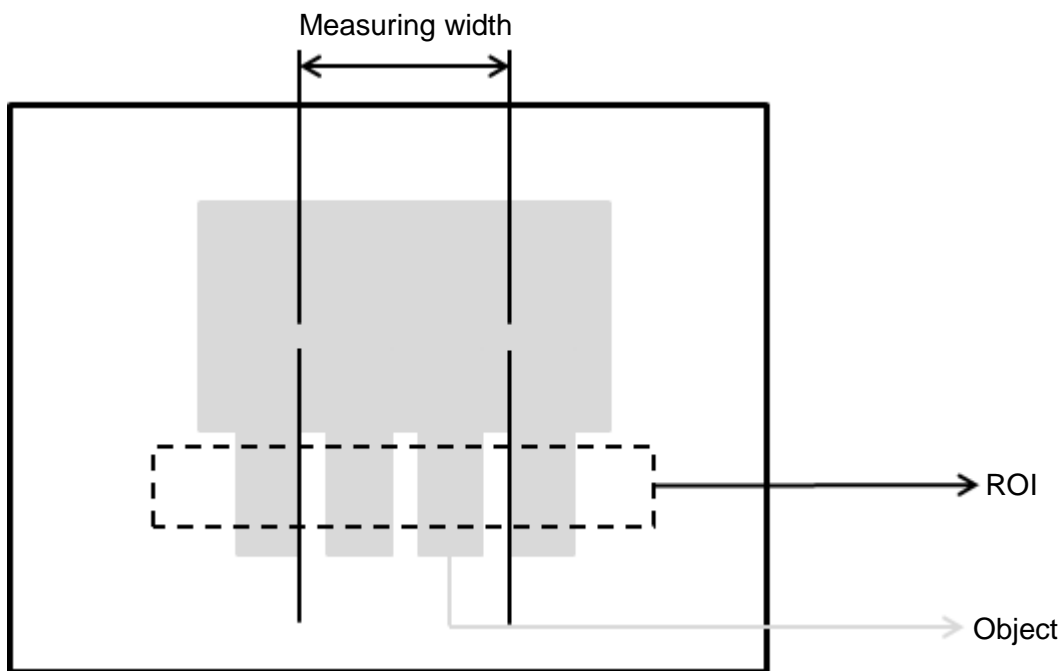

- ◆ The two following examples are for Ring and Arc ROIs.

Scanning direction: Clockwise

Search method: All edges

Measure method: Inside-out

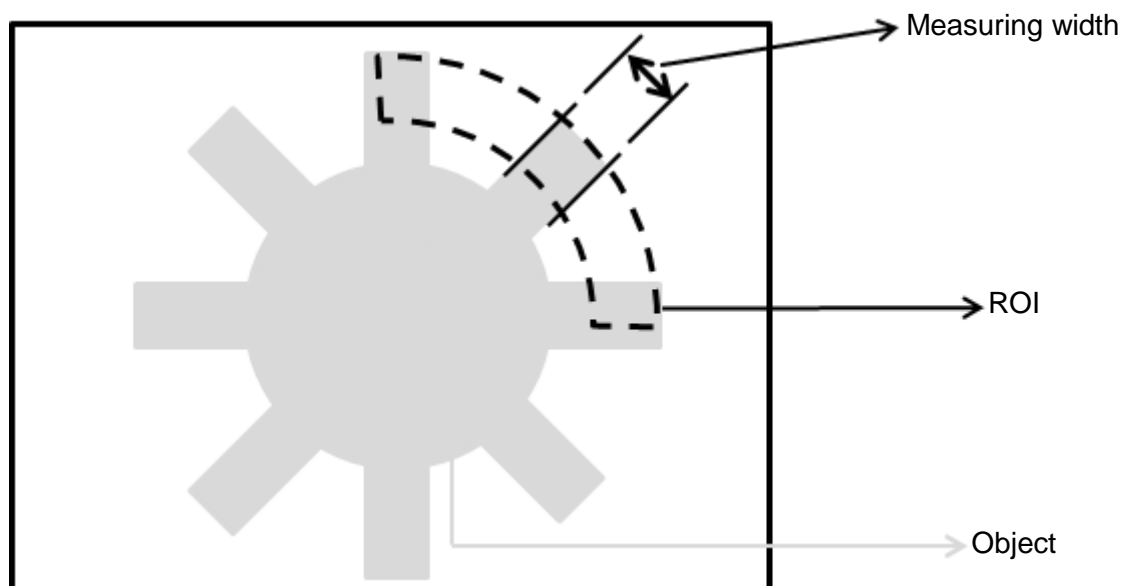

Scanning direction: Clockwise

Search method: Bright to dark

Angle: -15

Measure method: Out to in

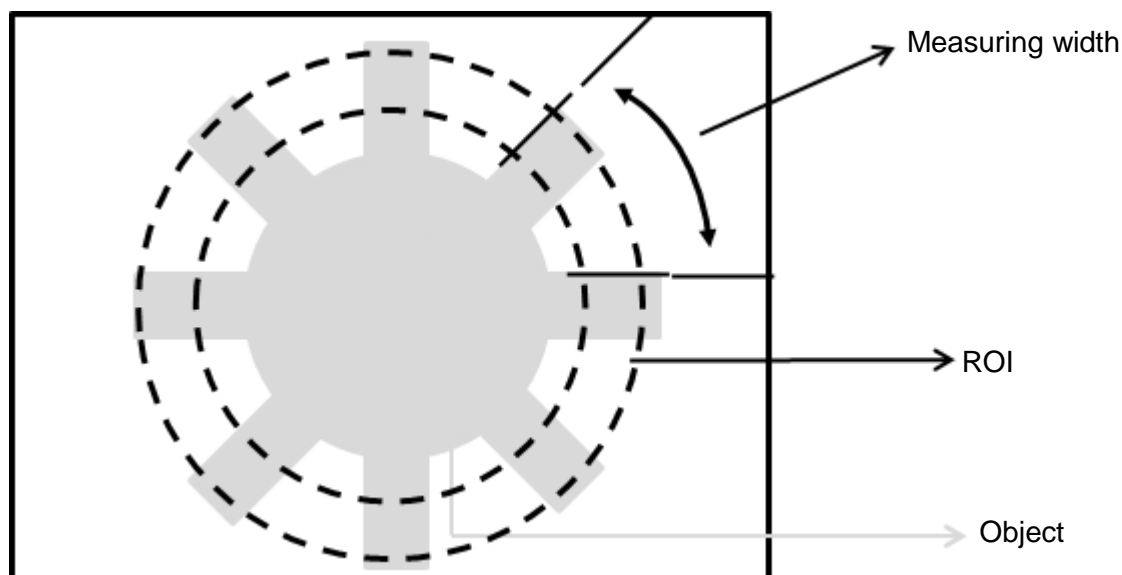

© Procedural Results

The Edge Width tool returns the following inspection results.

- Edge Width: outputs the width data found by the Edge Width tool (unit in pixels).
- First Edge Position X: outputs the X coordinate of the first edge position found by the Edge Width tool.

- First Edge Position Y: outputs the Y coordinate of the first edge position found by the Edge Width tool.
- First Edge Absolute Angle: when you select the Ring or Arc ROI, the First Edge Absolute Angle function outputs the absolute angle of the first edge found by the Edge Width tool.
- First Edge Relative Angle: when you select the Ring or Arc ROI, the First Edge Relative Angle function outputs the relative angle of the first edge found by the Edge Width tool.
- Second Edge Position X: outputs the X coordinate of the second edge position found by the Edge Width tool.
- Second Edge Position Y: outputs the Y coordinate of the second edge position found by the Edge Width tool.
- Second Edge Absolute Angle: when you select the Ring or Arc ROI, the First Edge Absolute Angle function outputs the absolute angle of the second edge found by the Edge Width tool.
- Second Edge Relative Angle: when you select the Ring or Arc ROI, the Second Edge Relative Angle function outputs the relative angle of the second edge found by the Edge Width tool.

◎ **Example**

- ◆ The first example is for ROIs other than Ring and Arc; the second example is for Arc.

Scanning direction: Horizontal

Search method: All edges

Measure method: Out to in

Inspection result: Edge width is 750 pixels

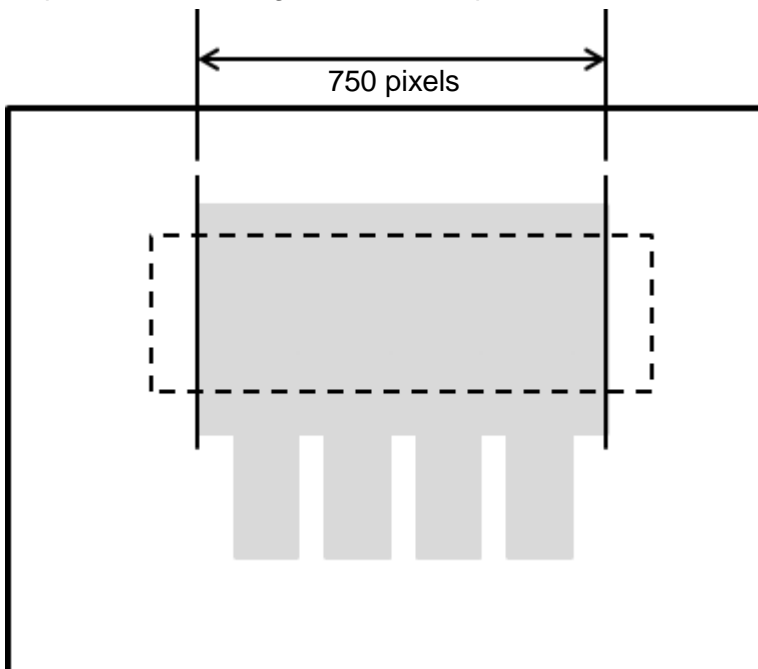

Scanning direction: Clockwise

Search method: All edges

Measure method: Inside-out

Inspection result: Edge width is 100 pixels

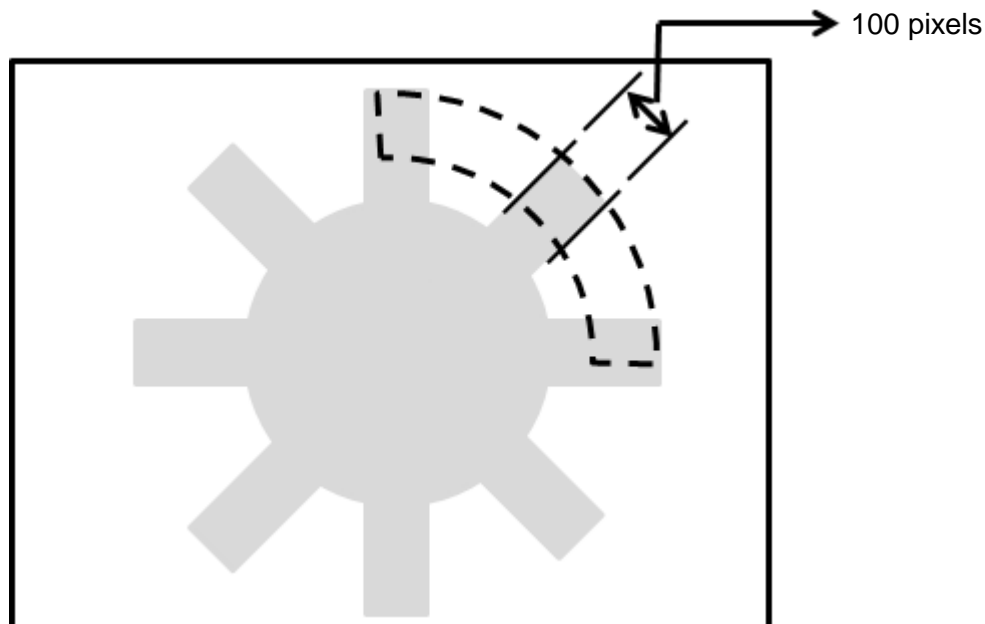

© Edge Width dialog box

The following picture shows the Edge Width inspection tool dialog box.

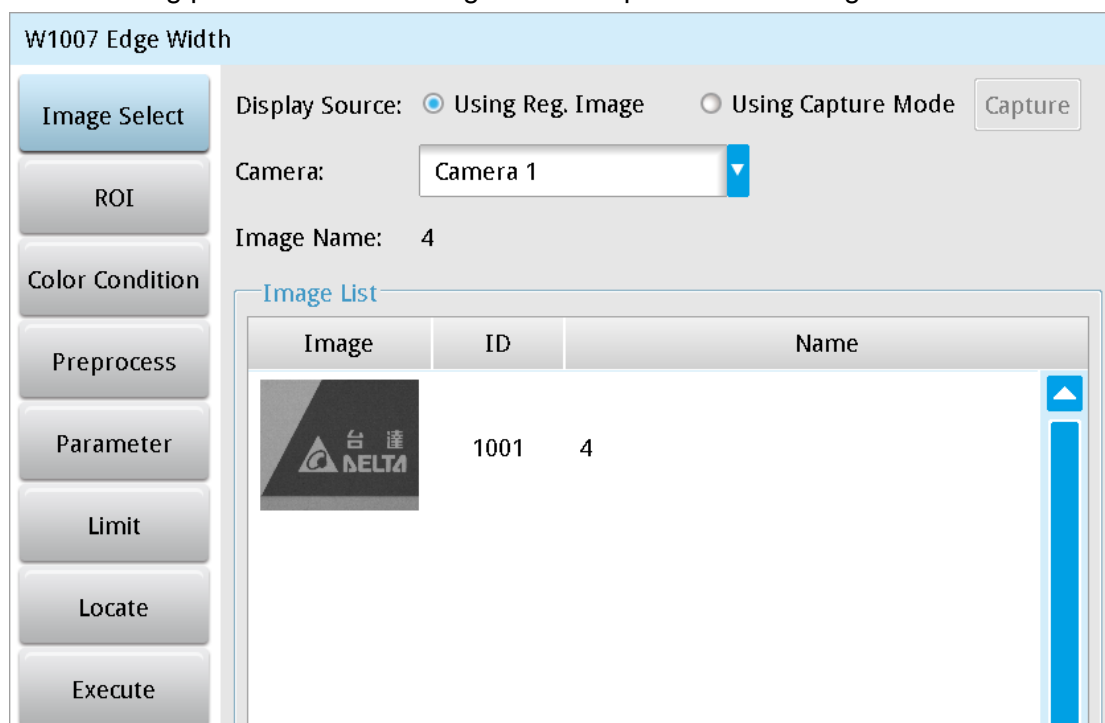

➤ **Image Select** (select Register Image)

Selects the image to be inspected from the register gallery. You can configure source cameras and inspect the image display source. When you select a different camera, the image table also switches to show the registered images acquired from that camera.

➤ **ROI** (configure detection region)

Specifies the inspection regions to be used in the inspection. The optional ROI shapes include Rectangle, Circle, Ellipse, Ring, Arc, Polygon, and Rotated Rect. The Polygon ROI supports up to 16 points. In addition, there are up to eight mask functions to ignore particular segments.

➤ **Color Condition**

Specifies the color processing for images from a color camera: Color to Binary, Color to Grayscale, RGB grayscale, R Grayscale, G Grayscale, and B Grayscale.

➤ **Preprocess**

Specifies the image processing to apply before inspections to enhance certain aspects of the image. Preprocessing methods include Binary, Dilation, Erosion, Average, Median, Laplacian, Sobel X, Sobel Y, Sobel XY, Brightness, Contrast, Shade, and Custom (filter). You can superimpose up to six methods or create a custom method by clicking **Custom**.

➤ **Parameters**

Adjusts the Edge Width inspection tool conditions.

Direction

When you select Ring or Arc for the ROI, you can then select Clockwise or Counterclockwise for the scanning direction. For other ROI shapes, you can select Left to Right, Right to Left, Upward, or Downward for the scanning direction.

Look For

Selects the search method: All Edges, Light to Dark, and Dark to Light.

Edge Strength

Specifies the threshold for the edge search (**Look For**), and you can fine-tune it between 0–100 based on the waveform displayed in the preview. When the peak is larger than the configured edge strength, **Look For** identifies the segment as an edge. As shown in the lower left picture, the system finds two edges when Edge Strength is set to 50. As shown in the lower right diagram, the system finds only one edge that is greater than the configured Edge Strength threshold of 70.

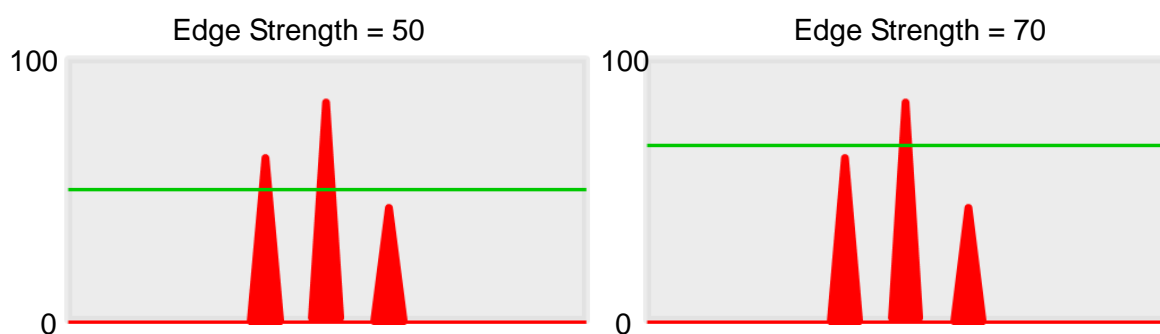

Lower

Use the Lower (limit) to filter small noise signals on the image, and the range is between 0–255. Peaks lower than the Lower value are filtered from the waveform. As shown in the lower left diagram, some noise appears when Lower is set to 0, but the noise is filtered out when Lower is set to 20.



Smoothing

Sets the RGB Grayscale for edge calculations between 1–30. When you increase Smoothing, the slope of waveform changes, attenuating the effect caused by noise signals.

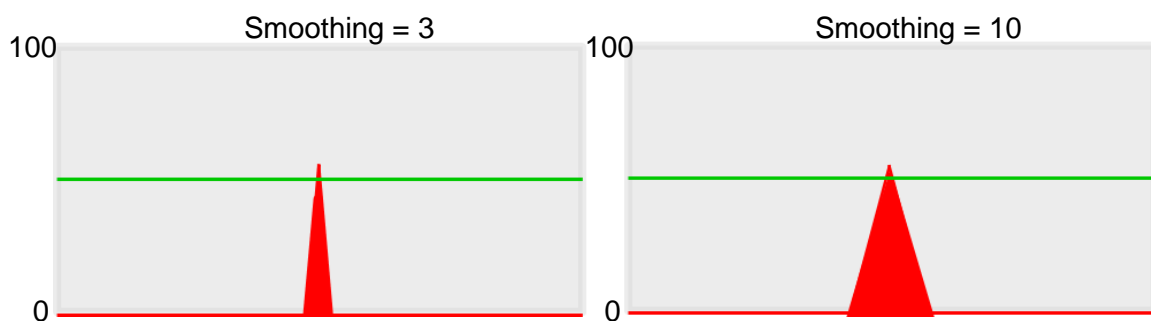

Angle

When the ROI is Ring or Arc, this sets the starting angle for the edge scan. The following pictures show starting angles of 0 and 45 degrees, respectively.

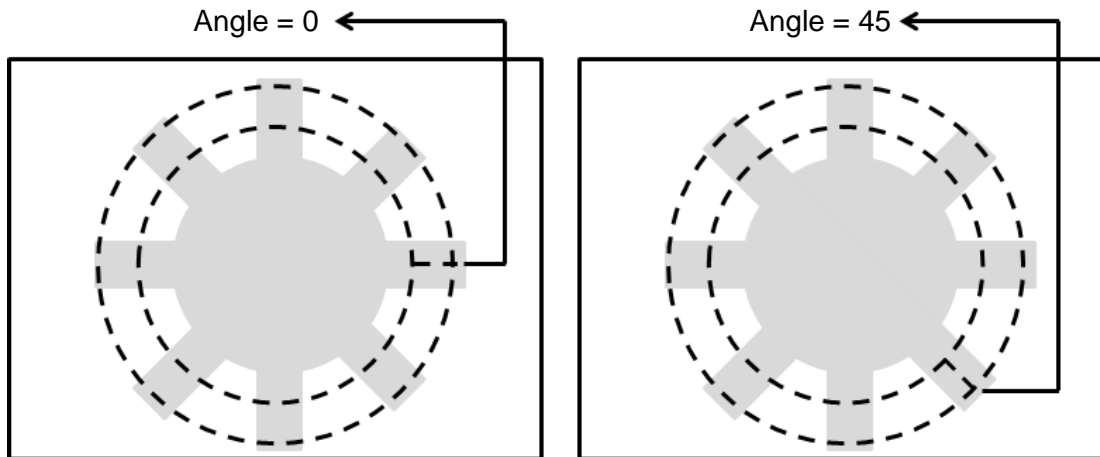

Reference

Output the Nth result when scanning multiple targets.

Origin

The position of the origin (0, 0) in System Setting is displayed on the upper left corner of the screen. You can enter new coordinates to move the origin to the new coordinates.

➤ Limit

After you complete the configurations, you can view the inspection results using register images through **Test Mode**. You can then configure the upper and lower limits in the Limit dialog box. The following items can be configured for the Edge Width tool.

- **Edge Width:** specifies the upper and lower limits of the angles detected by the Edge Width tool.
- **First Edge Position X:** specifies the upper and lower X coordinate limits of the first edge.
- **First Edge Position Y:** specifies the upper and lower Y coordinate limits of the first edge.
- **Second Edge Position X:** specifies the upper and lower X coordinate limits of the second edge.
- **Second Edge Position Y:** specifies the upper and lower Y coordinate limits of the second edge.
- **First Edge Absolute Angle:** when you select Ring or Arc for the ROI, there is an effective absolute angle for the first edge; specifies the upper and lower limits.
- **Second Edge Absolute Angle:** when you select Ring or Arc for the ROI, there is an effective absolute angle for the second edge; specifies the upper and lower limits.

► Locate

Specifies whether the inspection region follows an inspection result by adjusting its coordinates (X, Y) and Angles (Theta). The inspection tools you can use as a reference includes Shape, Blob, Edge Position and Edge Angle. As shown in the following diagram, specific marks (such as the cross on the object) can be used for the Locate function.

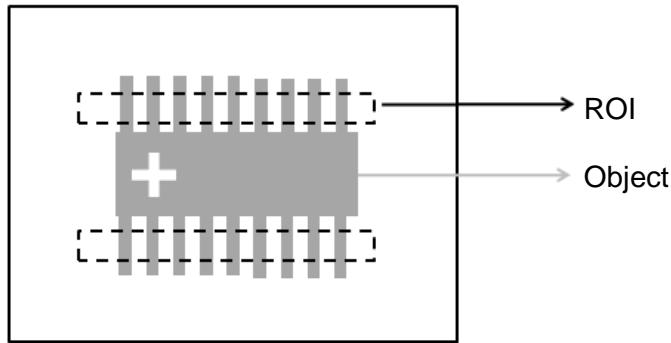

Locate Off

Locate On

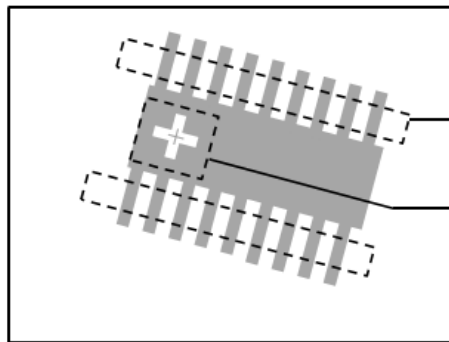
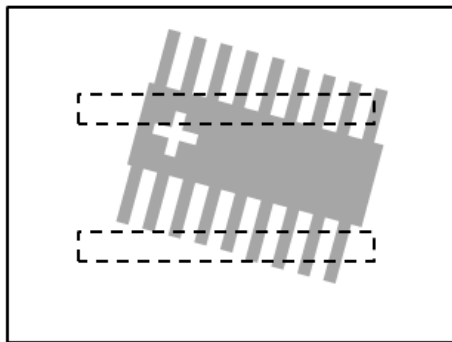

Corrected inspection region after using Locate

Target

► Three tools are also provided in this item for quick configuration.

Tool

Ref. Previous Unit	Ref. Available Unit	Ref. Unit
--------------------	---------------------	-----------

Ref. X :

Ref. Y :

Ref. Angle :

◆ Reference Previous Unit

Selects the nearest inspection tool that can provide reference for Locate, and automatically fills in the **Ref. X**, **Ref. Y**, and **Ref. Angle** fields.

◆ Reference Available Unit

Selects the nearest unit with Locate configured, and automatically fills in the **Ref. X**, **Ref. Y**, and **Ref. Angle** fields.

◆ Reference Unit

Arbitrarily selects an inspection tool that can provide locating reference, and automatically fills in the **Ref. X**, **Ref. Y**, and **Ref. Angle** fields.

 **Reference** Please refer to Section 9.1 for detailed Locate configurations.

⊙ Execute

Specifies whether to execute the inspection function in the inspection process.

➤ Always Execute

Always execute the inspection function in Run mode.

➤ Never Execute

Never execute the inspection function in Run mode.

⊙ Save

Saves all modified parameters and values.

⊙ Exit

Leaves the dialog box.

⊙ Output Item

➤ Window

Selects the output window for the total Judge result for the Edge Width tool on the designated interface.

➤ Item

- 1) **Edge Width (L)**: outputs the width data found by the Edge Width tool (unit in pixels).
- 2) **First Edge Position X (X1)**: outputs the X coordinate of the first edge position found by the Edge Width tool.
- 3) **First Edge Position Y (Y1)**: outputs the Y coordinate of the first edge position found by the Edge Width tool.
- 4) **First Edge Absolute Angle (AG1)**: when you select the Ring and Arc ROI, the First Edge Absolute Angle function outputs the absolute angle of the first edge found by the Edge Width tool.
- 5) **First Edge Relative Angle (RA1)**: when you select the Ring or Arc ROI, First Edge Relative Angle outputs the relative angle of the first edge found by the Edge Width tool.
- 6) **Second Edge Position X (X2)**: outputs the X coordinate of the second edge position found by the Edge Width tool.
- 7) **Second Edge Position Y (Y2)**: outputs the Y coordinate of the second edge position found by the Edge Width tool.

- 8) **Second Edge Absolute Angle (AG2)**: when you select the Ring or Arc ROI, First Edge Absolute Angle outputs the absolute angle of the second edge found by the Edge Width tool.
- 9) **Second Edge Relative Angle (RA2)**: when you select the Ring or Arc ROI, Second Edge Relative Angle outputs the relative angle of the second edge found by the Edge Width tool.
- 10) **Edge Width ID**: outputs the ID of the inspection tool.
- 11) **Edge Width (J) (L)**: outputs the logical (Judge) result of the edge widths found by the Edge Width.
- 12) **First Edge Position X (J) (X1)**: outputs the logical (Judge) result of the X coordinates of the first edge found by the Edge Position tool.
- 13) **First Edge Position Y (J) (Y1)**: outputs the logical (Judge) result of the Y coordinates of the first edge found by the Edge Position tool.
- 14) **First Edge Absolute Angle (J) (AG1)**: when you select the Ring or Arc ROI, First Edge Absolute Angle (J) outputs the logical (Judge) result of the absolute edge angle found by the Edge Width tool.
- 15) **Second Edge Position X (J) (X2)**: outputs the logical (Judge) result of the X coordinates of the second edge found by the Edge Position tool.
- 16) **Second Edge Position Y (J) (Y2)**: outputs the logical (Judge) result of the Y coordinates of the second edge found by the Edge Position tool.
- 17) **Second Edge Absolute Angle (J) (AG2)**: when you select the Ring and Arc ROI, First Edge Absolute Angle (J) outputs the logical (Judge) result of the absolute edge angle found by the Edge Width tool.

5.9 Shape

This tool compares samples (Patterns) previously stored in the controller, and then find the number of detections similar to the patterns, as well as the corresponding X and Y coordinates, angles, and degrees of similarity.

Algorithmic Processing

You must download the patterns that Shape looks for in advance. You must specify the parameters such as the search angles and range and degrees of similarity.

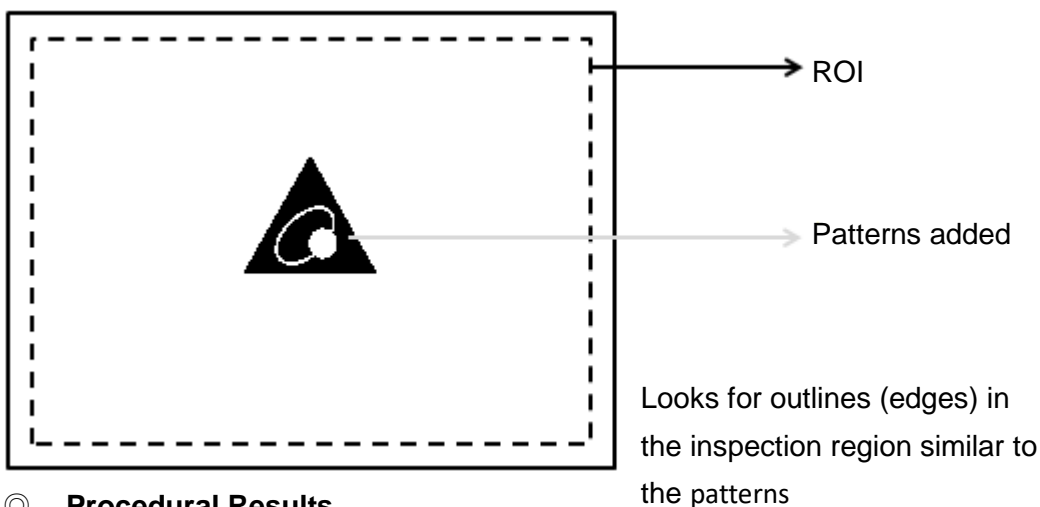

Procedural Results

Shape returns the following inspection results.

- Number of Shapes: outputs the number of shapes similar to the pattern.
- Shape Position X [N]: outputs the X coordinate of the Nth shape similar to the pattern.
- Shape Position Y [N]: outputs the Y coordinate of the Nth shape similar to the pattern.
- Similarity [N]: outputs the degree of similarity of the Nth shape similar to the pattern.
- Shape Angle [N]: outputs the angle of the Nth shape similar to the pattern.

Example

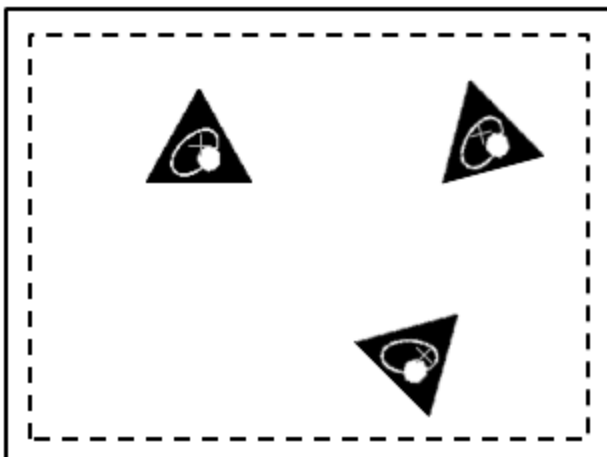

Number of Shapes = 3
 Similarity [1] = 95
 Shape Position X [1] = 400
 Shape Position Y [1] = 200
 Shape Angle [1] = 0

◎ Shape dialog box

The following picture shows the Shape inspection tool dialog box.

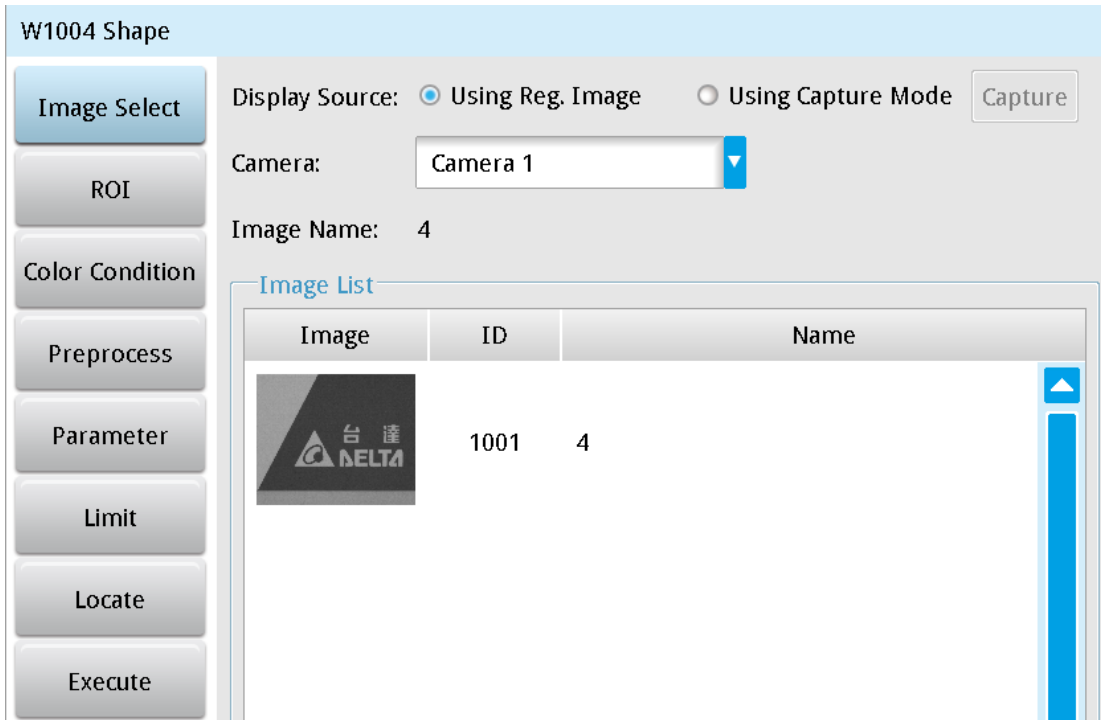

► Image Select (select Register Image)

Selects the image to be inspected from the register gallery. You can configure source cameras and inspect the image display source. When you select a different camera, the image table also switches to show the registered images acquired from that camera.

► ROI (configure detection region of interest)

Specifies the inspection regions to be used in the inspection. Optional ROI shapes include Rectangle, Circle, Arc, Ellipse, Ring, Polygon, and Rotated Rect. The Polygon ROI supports up to 16 points. In addition, there are up to eight mask functions to ignore particular segments.

► Color Condition

Selects the color processing for images from a color camera: Color to Binary, Color to Grayscale, RGB grayscale, R Grayscale, G Grayscale, and B Grayscale.

► Preprocess

Specifies the image processing to apply before inspections to enhance certain aspects of the image. Preprocessing methods include Binary, Dilation, Erosion, Average, Median, Laplacian, Sobel X, Sobel Y, Sobel XY, Brightness, Contrast, Shade, and Custom (filter). You can superimpose up to six methods or create a custom method by clicking **Custom**.

► Parameters

Adjusts the Shape inspection conditions.

Add Pattern

- ◆ **Angle:** specifies the range of angles to search for. A value of 10 means searching from -10 degrees to 10 degrees. A value of 179 means searching from -180 degrees to 180 degrees. A larger range of angles takes longer inspection times.
- ◆ **Scale Tolerance:** select this setting when the dimensions of the object to search vary.
- ◆ **Accuracy:** refers to the search accuracy; the options are: **Most Accurate**, **Accurate**, **General**, **Rough**, and **Most Rough**. A higher accuracy takes longer inspection times.
- ◆ **ROI/MASK:** use **Region** and **Region Mask** to select the shape to look for to build a model for the shape.

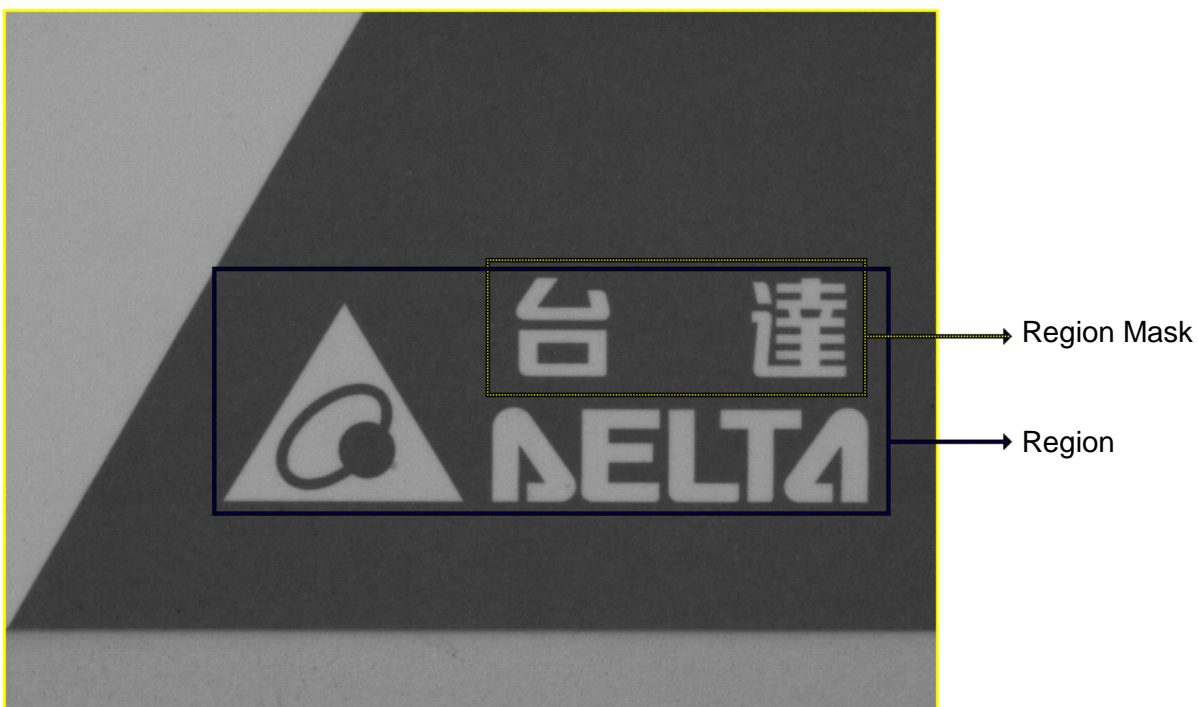

Shape Comparison Setting

- ◆ **Similarity:** specifies the degree of similarity to pattern for shape recognition.
- ◆ **Reference:** outputs the Nth result when scanning multiple targets.
- ◆ **Search Number:** specifies the number of shapes to look for.
- ◆ **Sort Rule:** when searching for multiple matching shapes, the following sorting methods are provided.
 - Similarity:** sorts shapes based on degrees of similarity; shapes of higher similarities are numbered first.
 - Horizontal Position Ascend:** sorts shapes based on the horizontal positions; smaller horizontal coordinates are numbered first.
 - Horizontal Position Descend:** sorts shapes based on the horizontal positions; larger horizontal coordinates are numbered first.
 - Vertical Position Ascend:** sorts shapes based on the vertical positions; smaller vertical coordinates are numbered first.

Vertical Position Descend: sorts shapes based on the vertical positions; larger vertical coordinates are numbered first.

Top Left to Bottom Right: sorts from top left to bottom right of the screen.

Bottom Right to Top Left: sorts from bottom right to top left of the screen.

Top Right to Bottom Left: sorts from top right to bottom left of the screen.

Bottom Left to Top Right: sorts from bottom left to top right of the screen.

- ◆ **Contrast Sensitive:** specifies the contrast between shape and background. When the characteristic shape contrast is strong, use **Very Coarse** to speed up the inspection. When the contrast is weak, use **Very Sensitive** to improve the recognition accuracy.
- ◆ **Ignore Polarity:** specifies whether to ignore edge polarity. As shown below, the tool finds both the black mark on white background and white mark on black background, regardless of edge polarity when any of the two is configured as the pattern.

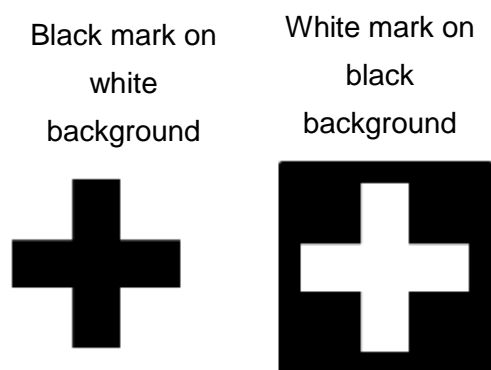

- ◆ **Enable Rotation Center:** the X and Y outputs from the inspection are both based on the center position of the pattern. When you enable this option, you can manually adjust the X and Y coordinates of the rotation center. The X and Y inspection outputs are then based on the specified position.
- ◆ **Origin:** the position of the origin (0, 0) in the System Setting is displayed on the upper left corner of the screen. You can enter different coordinates to change and move the origin to the new coordinates.

➤ **Limit**

Specifies the upper and lower limits for inspection results to determine whether the result is qualified. The following items can be configured in Shape.

Number of Shapes: specifies the upper and lower limits of the number of shapes.

Shape Position X: specifies the shapes' upper and lower X coordinate limits.

Shape Position Y: specifies the shapes' upper and lower Y coordinate limits.

Similarity: specifies the upper and lower limits of shape similarity.

Shape Angle: specifies the upper and lower limits of shape angles.

► Locate

Specifies whether the inspection region follows an inspection result by adjusting its coordinates (X, Y) and Angles (Theta). The inspection tools you can use as a reference includes Shape, Blob, Edge Position and Edge Angle. As shown in the following diagram, specific marks (such as the cross on the object) can be used for the Locate function.

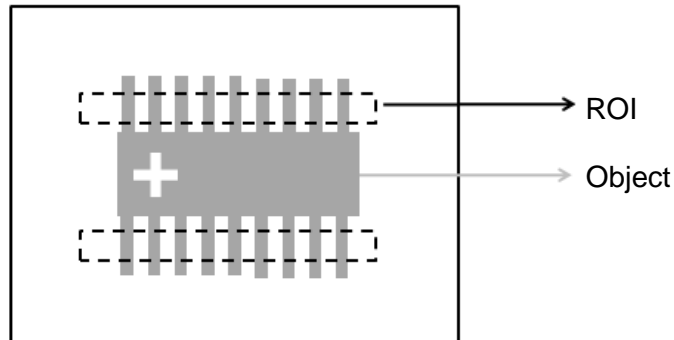

Locate Off

Locate On

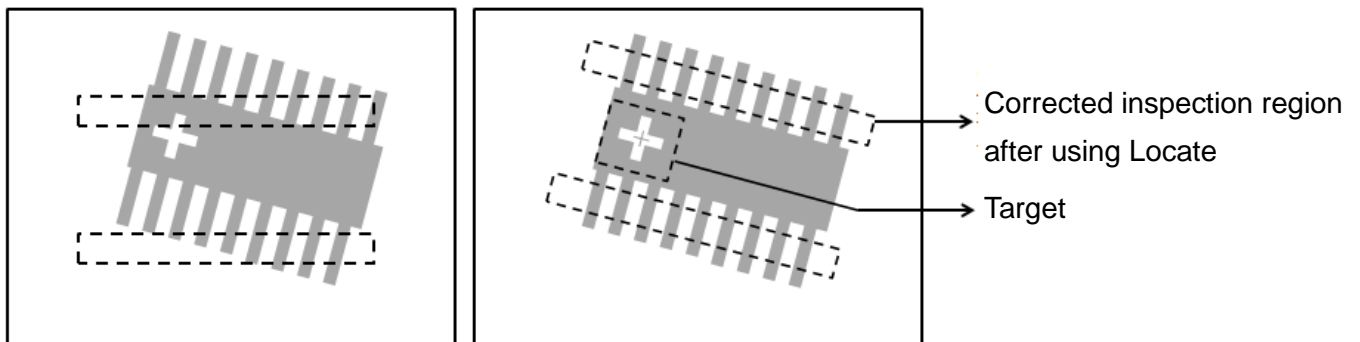

► Three tools are also provided in this item for quick configuration.

Tool

Ref. Previous Unit	Ref. Available Unit	Ref. Unit
--------------------	---------------------	-----------

Ref. X :	<input type="text" value="None"/>	Select	CLEAR
Ref. Y :	<input type="text" value="None"/>	Select	CLEAR
Ref. Angle :	<input type="text" value="None"/>	Select	CLEAR

◆ Reference Previous Unit

Selects the nearest inspection tool that can provide reference for Locate, and automatically fills in the **Ref. X**, **Ref. Y**, and **Ref. Angle** fields.

◆ Reference Available Unit

Selects the nearest unit with Locate configured, and automatically fills in the **Ref. X**, **Ref. Y**, and **Ref. Angle** fields.

◆ Reference Unit

Arbitrarily selects an inspection tool that can provide locating reference, and automatically fills in the **Ref. X**, **Ref. Y**, and **Ref. Angle** fields.

 **Reference** Please refer to Section 9.1 for detailed Locate configurations.

⊙ Execute

Specifies whether to execute the inspection function in the inspection process.

➤ Always Execute

Always execute the inspection function in Run mode.

➤ Never Execute

Never execute the inspection function in Run mode.

⊙ Save

Saves all modified parameters and values.

⊙ Exit

Leaves the dialog box.

⊙ Output Item

➤ Window

Selects the output window for the total Judge result for the Shape tool on the designated interface.

➤ Item

- 1) **Number of Shapes**: outputs the number of shapes found by the Shape tool.
- 2) **Shape Position X [N]**: outputs the X coordinate of the Nth shape found by the Shape tool.
- 3) **Shape Position Y [N]**: outputs the Y coordinate of the Nth shape found by the Shape tool.
- 4) **Shape Angle [N]**: outputs the angle of the Nth shape found by the Shape tool.
- 5) **Similarity [N]**: outputs the degree of similarity of the Nth shape found by the Shape tool.
- 6) **Maximum Shape Position X**: outputs the maximum X coordinate found by the Shape tool.
- 7) **Minimum Shape Position X**: outputs the minimum X coordinate found by the Shape tool.
- 8) **Maximum Shape Position Y**: outputs the maximum Y coordinate found by the Shape tool.
- 9) **Minimum Shape Position Y**: outputs the minimum Y coordinate found by the Shape tool.
- 10) **Shape ID**: outputs the ID of the inspection tool.
- 11) **Number of Shapes (J)**: outputs the logical (Judge) result of the number of shapes found by the Shape tool.
- 12) **Shape Position X (J) [N]**: outputs the logical (Judge) result of the Nth shape's X coordinate found by the Shape tool.

- 13) **Shape Position Y (J) [N]**: outputs the logical (Judge) result of the Nth shape's Y coordinate found by the Shape tool.
- 14) **Shape Angle (J) [N]**: outputs the logical (Judge) result of the angle of the Nth shape found by the Shape tool.
- 15) **Similarity (J) [N]**: outputs the logical (Judge) result of the Nth shape's degree of similarity found by the Shape tool.

5.10 Intensity

The Intensity tool measures Maximum Intensity, Minimum Intensity, Average Intensity, and Standard Deviation of Intensity on a gray scale image in the inspection region.

Algorithmic Processing

As shown in the following picture, the inspection region consists of three different gray scale distributions of 200, 100, and 30; the Intensity tool finds the four following results.

- Maximum Intensity = 200
- Minimum Intensity = 30
- Average Intensity = $(30+100+200) / 3 = 110$
- Standard Deviation of Intensity = 121

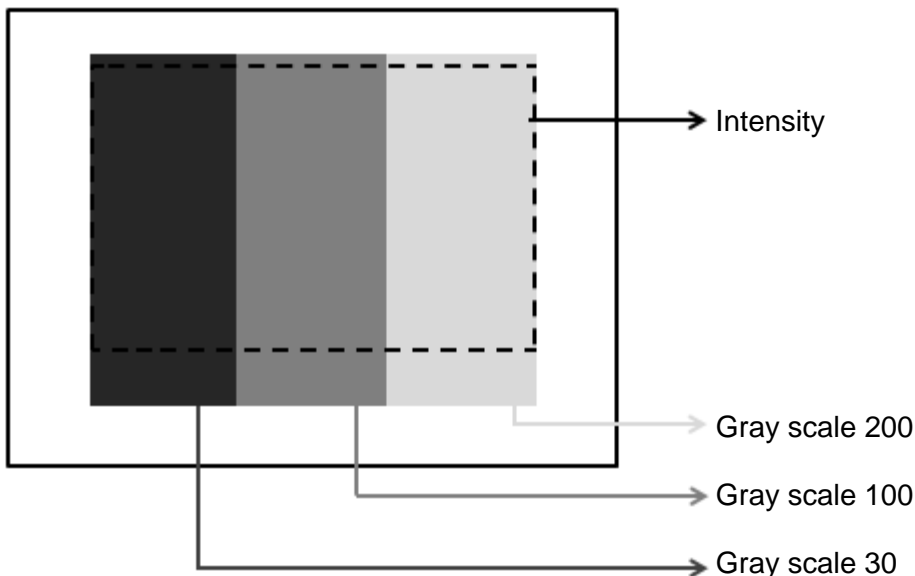

Procedural Results

The Intensity tool returns the following inspection results.

- Average Intensity: outputs the average intensity in the inspection region.
- Standard Deviation of Intensity: outputs the standard deviation of intensity in the inspection region.
- Maximum Intensity: outputs the maximum intensity in the inspection region.

- **Minimum Intensity:** outputs the minimum intensity in the inspection region.

◎ **Example**

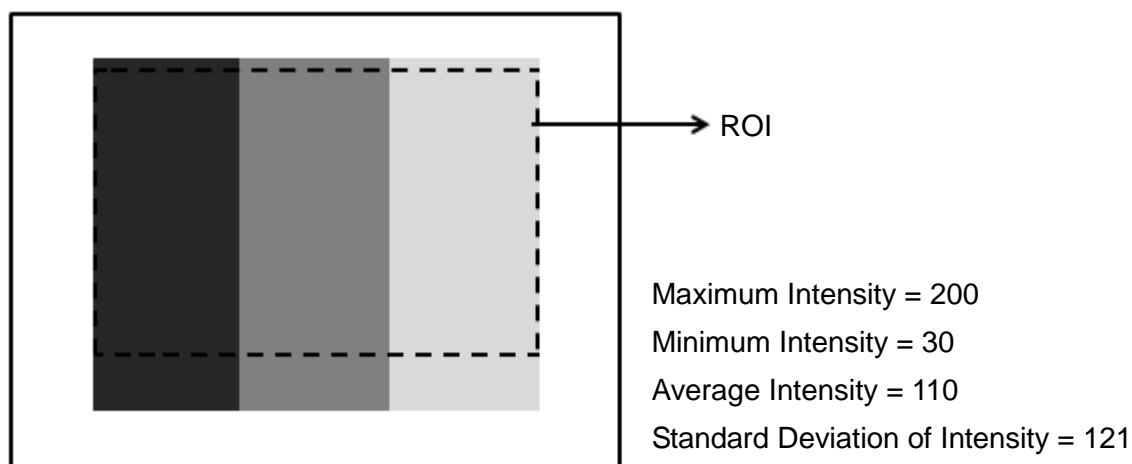

◎ **Intensity dialog box**

The following picture shows the Intensity inspection tool dialog box.

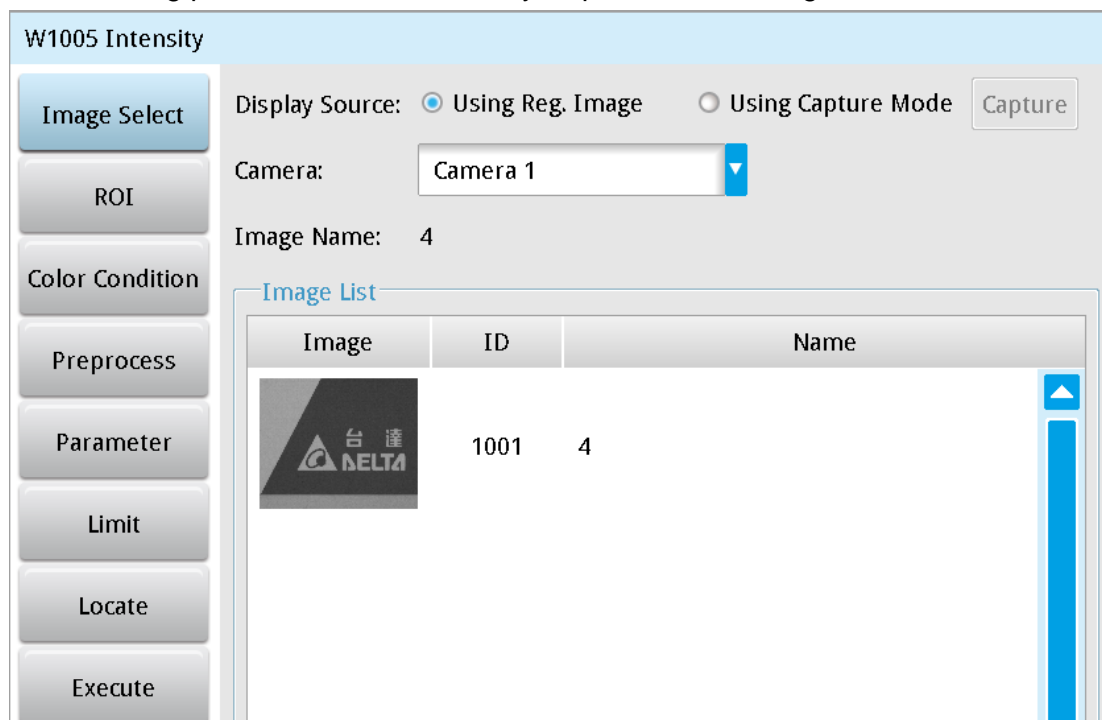

- **Image Select** (select Register Image)

Selects the image to be inspected from the register gallery. You can configure source cameras and inspect the image display source. When you select a different camera, the image table also switches to show the registered images acquired from that camera.

➤ **ROI** (configure detection region of interest)

Specifies the inspection regions to be used in the inspection. The optional ROI shapes include Rectangle, Circle, Arc, Ellipse, Ring, Polygon, and Rotated Rect. The Polygon ROI supports up to 16 points. In addition, there are up to eight mask functions to ignore particular segments.

➤ **Color Condition**

Selects the color processing for images from a color camera: Color to Binary, Color to Grayscale, RGB grayscale, R Grayscale, G Grayscale, and B Grayscale.

➤ **Preprocess**

Specifies the image processing to apply before inspections to enhance certain aspects of the image. Preprocessing methods include Binary, Dilation, Erosion, Average, Median, Laplacian, Sobel X, Sobel Y, Sobel XY, Brightness, Contrast, Shade, and Custom (filter). You can superimpose up to six methods or create a custom method by clicking **Custom**.

➤ **Parameters**

Adjusts the Intensity inspection tool conditions.

➤ **Limit**

After you complete the configurations, you can view the inspection results using register images through **Test Mode**. You can then configure the upper and lower limits in the Limit dialog box. The following items can be configured for the Intensity tool:

Area: specifies the upper and lower limits of Area.

➤ **Locate**

Specifies whether the inspection region follows an inspection result by adjusting its coordinates (X, Y) and Angles (Theta). The inspection tools you can use as a reference includes Shape, Blob, Edge Position and Edge Angle. As shown in the following diagram, specific marks (such as the cross on the object) can be used for the Locate function.

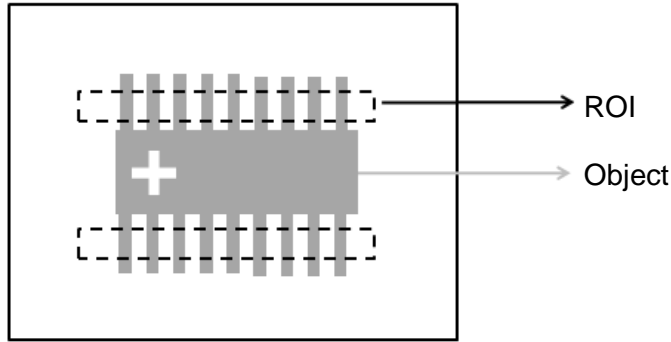

Locate Off

Locate On

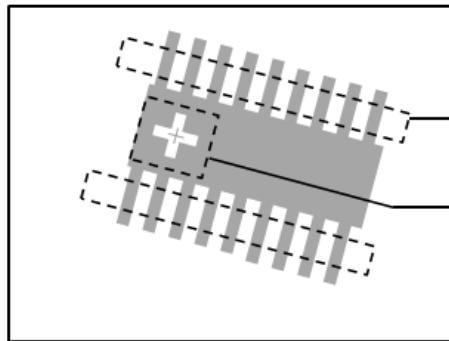
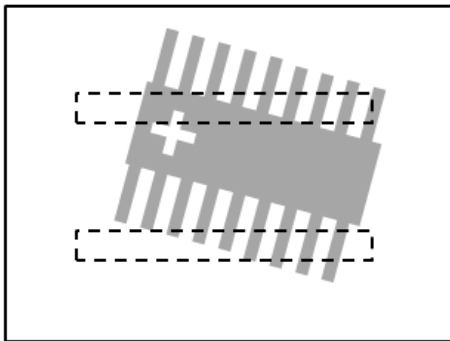

➤ Three tools are also provided in this item for quick configuration.

Tool

Ref. Previous Unit

Ref. Available Unit

Ref. Unit

Ref. X :

Ref. Y :

Ref. Angle :

◆ **Reference Previous Unit**

Selects the nearest inspection tool that can provide reference for Locate, and automatically fills in the **Ref. X**, **Ref. Y**, and **Ref. Angle** fields.

◆ **Reference Available Unit**

Selects the nearest unit with Locate configured, and automatically fills in the **Ref. X**, **Ref. Y**, and **Ref. Angle** fields.

◆ **Reference Unit**

Arbitrarily selects an inspection tool that can provide locating reference, and automatically fills in the **Ref. X**, **Ref. Y**, and **Ref. Angle** fields.

Reference Please refer to Section 9.1 for detailed Locate configurations.

⊙ **Execute**

Specifies whether to execute the inspection function in the inspection process.

➤ **Always Execute**

Always execute the inspection function in Run mode.

➤ **Never Execute**

Never execute the inspection function in Run mode.

⊙ **Save**

Saves all modified parameters and values.

⊙ **Exit**

Leaves the dialog box.

⊙ **Output Item**

➤ **Window**

Selects the output window, the total Judge result for the Intensity tool on the designated interface.

➤ **Item**

- 1) **Average Intensity**: outputs the average intensity found by the Image Intensity tool.
- 2) **Standard Deviation of Intensity**: outputs the standard deviation of intensity found by the Image Intensity tool.
- 3) **Maximum Intensity**: outputs the maximum intensity found by the Image Intensity tool.
- 4) **Minimum Intensity**: outputs the minimum intensity found by the Image Intensity tool.
- 5) **Image Intensity ID**: outputs the ID of the inspection tool.
- 6) **Average Intensity (J)**: outputs the logical (Judge) result of the average intensity found by the Image Intensity tool.
- 7) **Standard Deviation of Intensity (J)**: outputs the logical (Judge) result of the standard deviation of intensity found by the Image Intensity tool.
- 8) **Maximum Intensity (J)**: outputs the logical (Judge) result of the maximum intensity found by the Image Intensity tool.
- 9) **Minimum Intensity (J)**: outputs the logical (Judge) result of the minimum intensity found by the Image Intensity tool.

5.11 Position Trace

Position Trace is an advanced function of the Edge Width tool and has identical search methods. Using a rectangular ROI as an example, you can configure the search range to find edges through horizontal or vertical scanning. When the tool detects segments of increased contrast on the image, the tool identifies the region as a target edge. A feature of Position Trace is that it can simultaneously find multiple edge positions on a surface and output the coordinates.

⊙ **Algorithmic Processing**

➤ Position Trace Scan Methods

Selects the ROI. The ROI options provide differing edge scanning methods.

- ◆ When you select an ROI other than Ring or Arc, Position Trace calculates the furthest and the nearest edges relative to the screen origin and marks the two edges. This includes the two common conditions shown below.

Scanning direction: Left to Right

Search method: Bright to dark

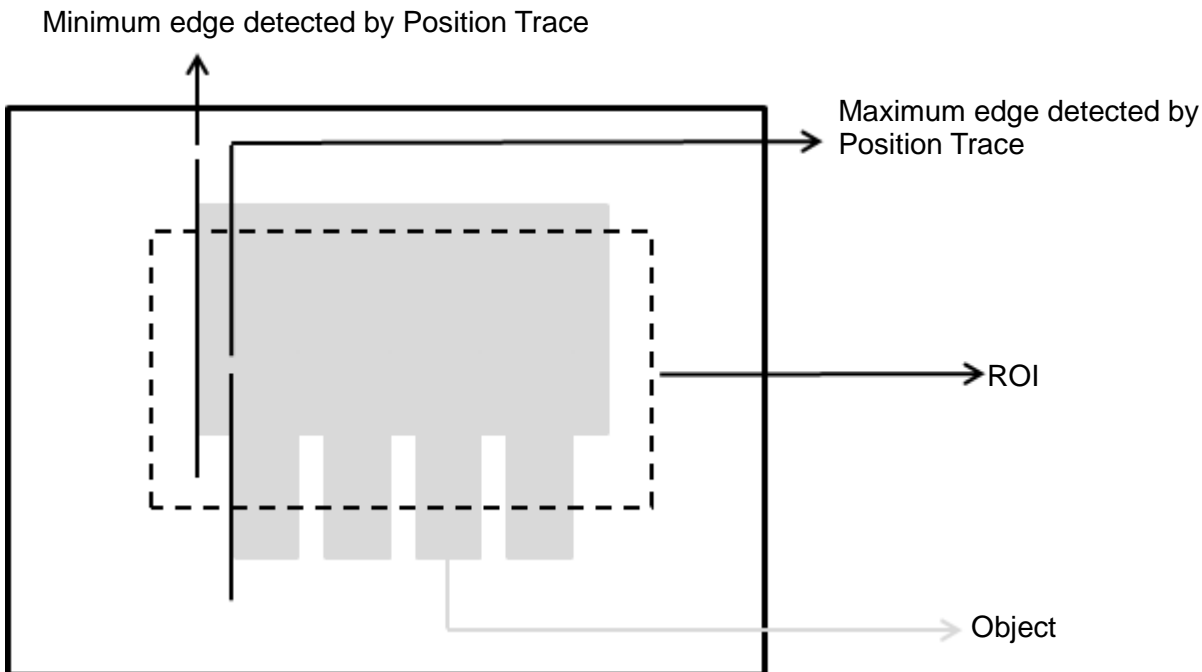

Scanning direction: Downward

Search method: All edges

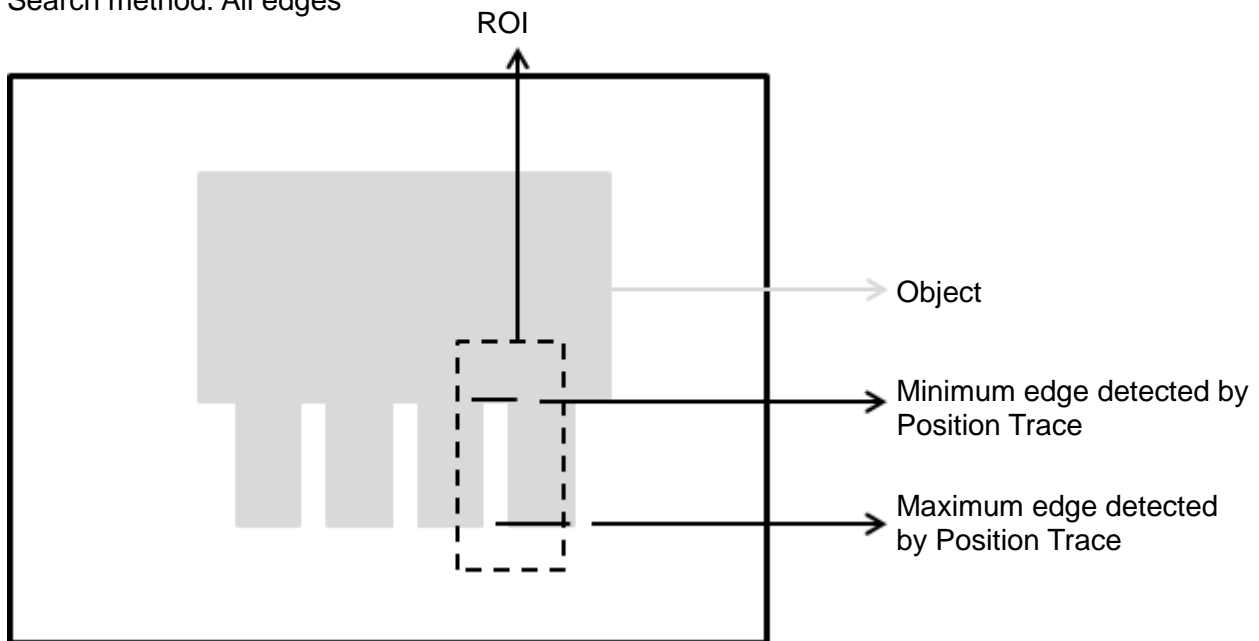

- ◆ When you select a Ring or Arc ROI, Position Trace calculates the furthest and the nearest edges relative to the origin (the center of the circle regressed from all positions detected on the object) and marks the two edges. This includes the two common conditions shown as follows.

Scanning direction: Outside→Center

Search method: Bright to dark

Angle: 0

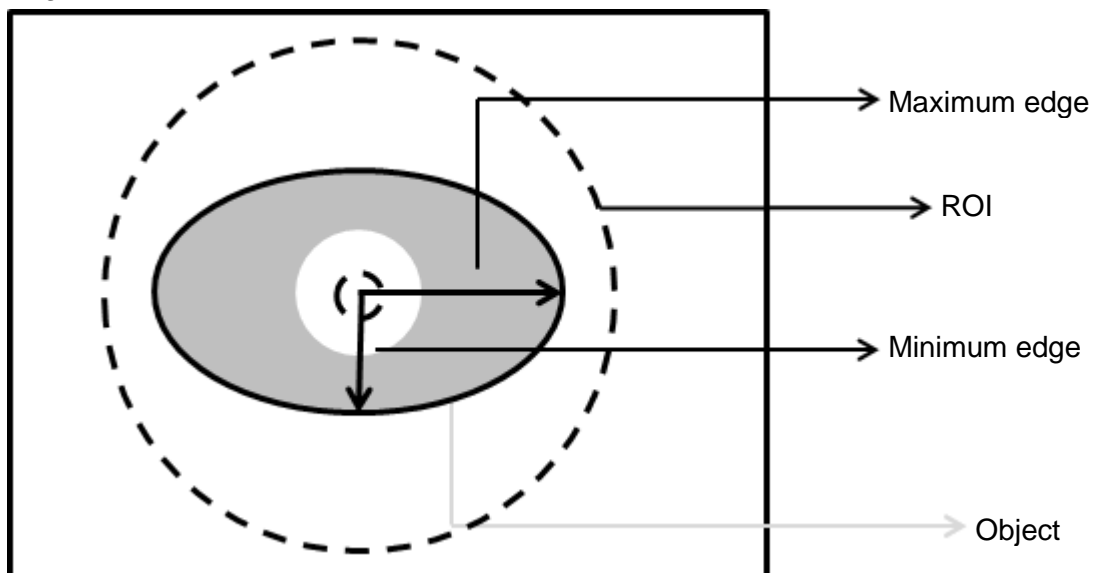

Scanning direction: Inside-Out

Search method: All edges

Angle: 0

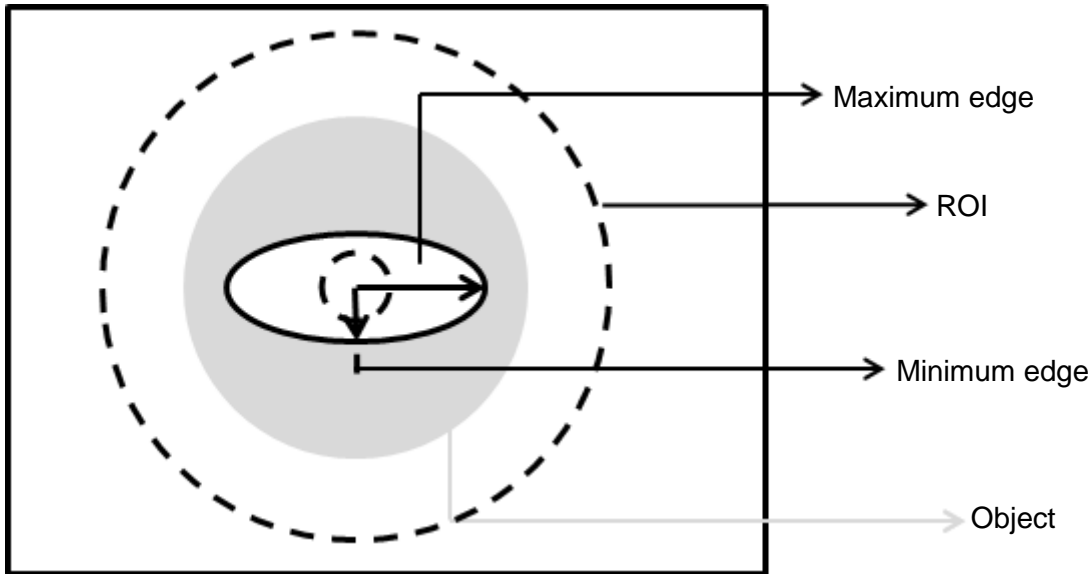

© Procedural Results

The Position Trace inspection tool returns the following inspection results.

- Number of Segments: outputs the total number of edges found by the Position Trace tool.
- Maximum Edge Position X: outputs the X coordinate of the maximum edge position detected in the scanned region by the Position Trace tool.
- Minimum Edge Position X: outputs the X coordinate of the minimum edge position detected in the scanned region by the Position Trace tool.
- Maximum Edge Position Y: outputs the Y coordinate of the maximum edge position detected in the scanned region by the Position Trace tool.
- Minimum Edge Position Y: outputs the Y coordinate of the minimum edge position detected in the scanned region by the Position Trace tool.
- Average Edge Position X: outputs the X coordinate of the average edge position detected in the scanned region by the Position Trace tool.
- Average Edge Position Y: outputs the Y coordinate of the average edge position detected in the scanned region by the Position Trace tool.
- Roundness: when you select Ring or Arc for the ROI, the system detects all edge positions on the object and regresses the roundness data.
- Circle Center Position X: when you select Ring or Arc for the ROI, the system detects all edge positions on the object and regresses the X coordinate of the center of the circle.
- Circle Center Position Y: when you select Ring or Arc for the ROI, the system detects all edge positions on the object and regresses the Y coordinate of the center of the circle.
- Circle Radius: outputs all radius values for circles fitting all edge positions found by the Position Trace tool.
- Maximum Vertex Pitch: outputs the widest pitch among vertexes found by the Position Trace tool.

- Minimum Vertex Pitch: outputs the shortest pitch among vertexes found by the Position Trace tool.
- Edge Position X: outputs the X coordinate of the assigned edge position selected in the parameters configured in the Position Trace tool.
- Edge Position Y: outputs the Y coordinate of the assigned edge position selected in the parameters configured in the Position Trace tool.
- Edge Distance: outputs the distance between the assigned edge position selected in the parameters configured in the Position Trace tool and the edge of the fitting line/circle.
- Vertex Position X: outputs the X coordinate of the assigned vertex among vertexes found by the Position Trace tool.
- Vertex Position Y: outputs the Y coordinate of the assigned vertex among vertexes found by the Position Trace tool.
- Vertex Pitch: outputs the assigned pitch data among vertexes found by the Position Trace tool.

◎ **Example**

- ◆ For ROIs other than Ring and Arc:

Scanning direction: Left to Right

Search method: Bright to dark

Inspection result: the coordinates of the maximum edge position is (200, 310) and the coordinates of the minimum edge position is (170, 200). The tool can identify gaps on the surface based on these data.

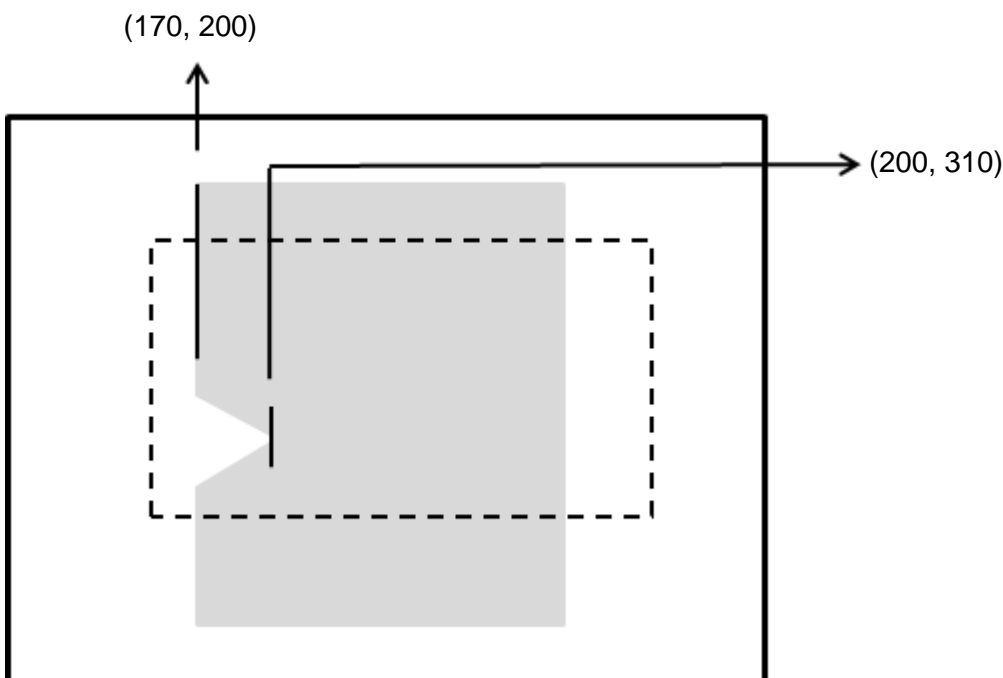

◆ For Ring and Arc ROIs:

Scanning direction: Outside→Center

Search method: Bright to dark

Angle: 0

Inspection result: Maximum radius is 160 (480-320) and minimum radius is 60 (300-240)

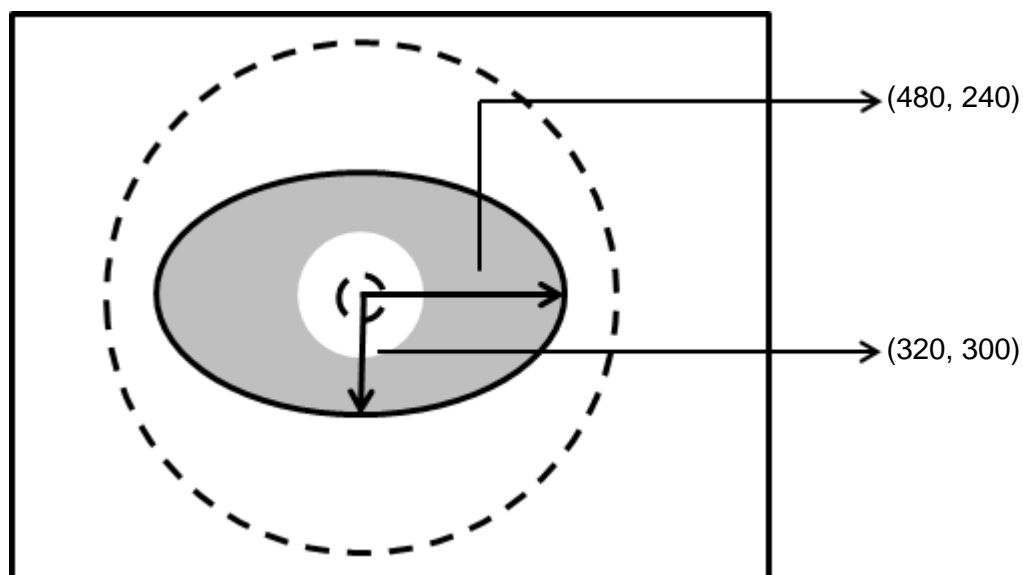

◎ Position Trace inspection tool dialog box

W1006 Position Trace

Image Select Display Source: Using Reg. Image Using Capture Mode Capture

ROI Camera: Camera 1

Color Condition Image Name: 4

Preprocess

Parameter

Limit

Locate

Execute

Image List

Image	ID	Name
	1001	4

➤ **Image Select** (select Register Image)

Selects the image to be inspected from the register gallery. You can configure source cameras and inspect the image display source. When you select a different camera, the image table also switches to show the registered images acquired from that camera.

➤ **ROI** (configure detection region)

Specifies the inspection regions to be used in the inspection. The optional ROI shapes include Rectangle, Ring, Arc, and Rotated Rect. Up to 8 mask functions are also provided for masking unwanted segments.

➤ **Color Condition**

Specifies the color processing for images from a color camera: Color to Binary, Color to Grayscale, RGB grayscale, R Grayscale, G Grayscale, and B Grayscale.

➤ **Preprocess**

Specifies the image processing to apply before inspections to enhance certain aspects of the image. Preprocessing methods include Binary, Dilation, Erosion, Average, Median, Laplacian, Sobel X, Sobel Y, Sobel XY, Brightness, Contrast, Shade, and Custom (filter). You can superimpose up to six methods or create a custom method by clicking **Custom**.

➤ **Parameters**

Adjusts the Position Trace inspection tool conditions.

Direction

When you specify Ring or Arc for the ROI, you can then select Center→Outside or Outside→Center for the scanning direction. For other ROI shapes, you can select Left to Right, Right to Left, Upward, or Downward for the scanning direction.

Look For

Specifies the search method: All Edges, Light to Dark, and Dark to Light.

Edge Strength

Specifies the threshold for the edge search (**Look For**), and you can fine-tune it between 0–100 based on the waveform displayed in the preview. When the peak is larger than the configured edge strength, **Look For** identifies the segment as an edge. As shown in the lower left picture, the system finds two edges when Edge Strength is set to 50. As shown in the lower right diagram, the system finds only one edge that is greater than the configured Edge Strength threshold of 70.

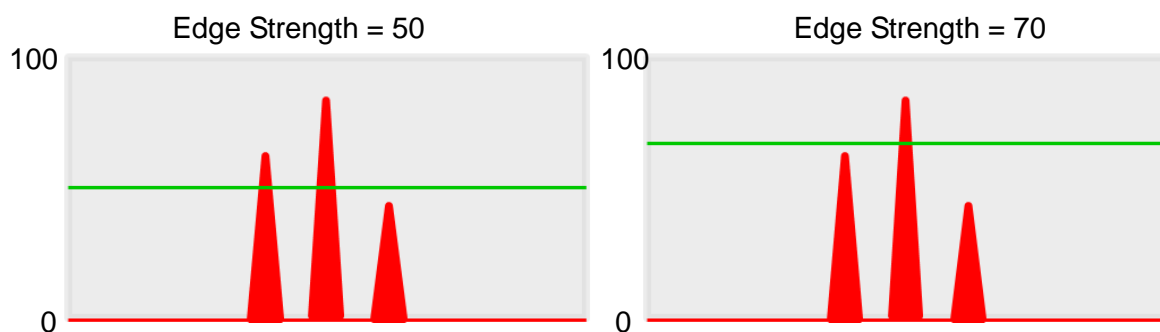

Lower

Use the Lower (limit) to filter small noise signals on the image, and the range is between 0–255. Peaks lower than the Lower value are filtered from the waveform. As shown in the lower left diagram, some noise appears when Lower is set to 0, but the noise is filtered out when Lower is set to 20.

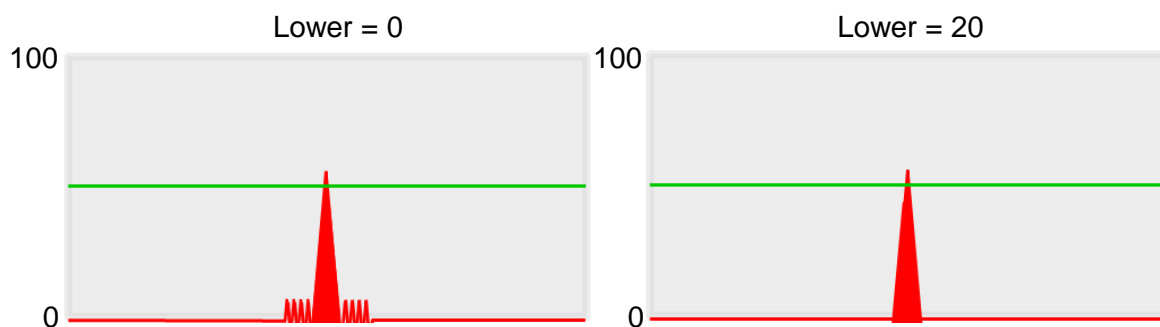

Smoothing

Sets the RGB Grayscale for edge calculations between 1–30. When you increase Smoothing, the slope of waveform changes, attenuating the effect caused by noise signals.

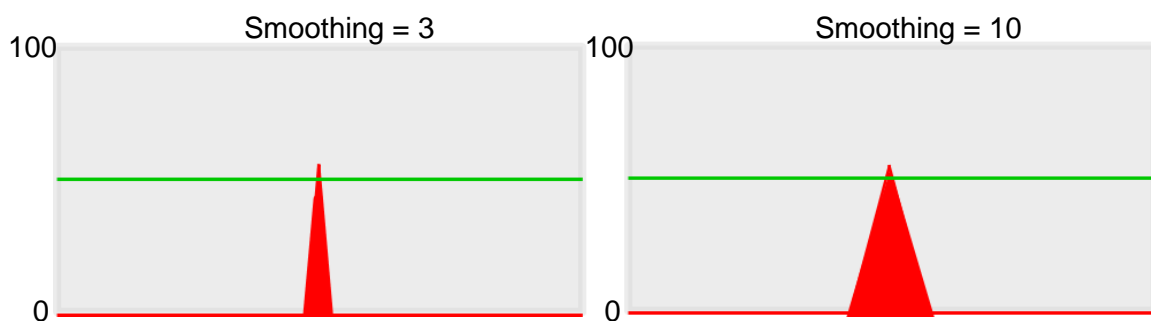

Angle

When the ROI is Ring or Arc, this sets the starting angle for the edge scan. The following pictures show starting angles of 0 and 45 degrees, respectively.

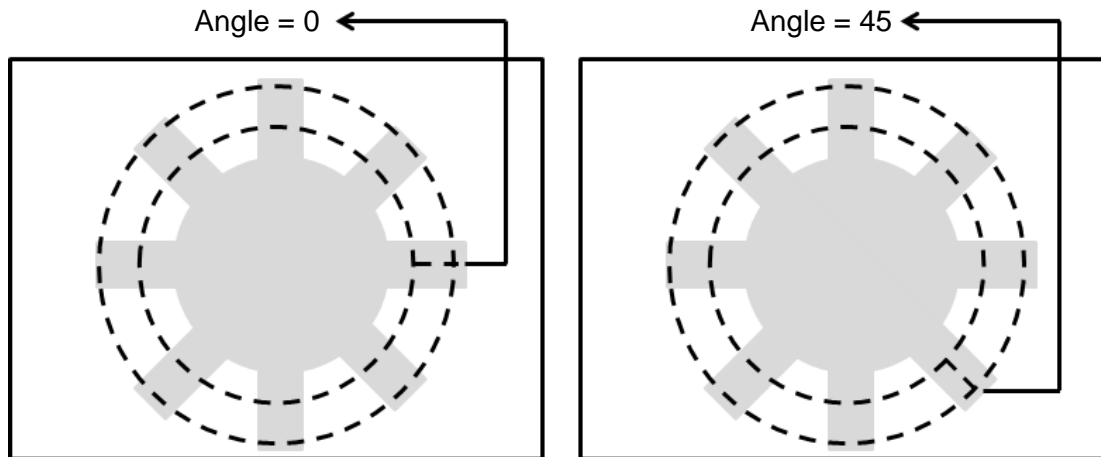

Segment Width

When you specify an ROI other than Ring or Arc, the range is between 1–128. When you specify Ring or Arc for the ROI, the range is between 0.1–45.0. Segment Width is the width of the horizontal pixel in each system scan.

Segment Offset

When you set Segment Width to 4 and Segment Offset to 1, the system horizontally offsets one pixel after completing each edge scan of a width of four pixels before proceeding to another four-pixel edge scan. The range is between 0.1–45.

Vertex Inspection

➤ Vertex Function

Enable Vertex Inspection.

➤ Vertex Search Mode

Specifies whether to search the top or bottom vertex.

➤ Vertex Exclusivity Width

Determines the number of vertexes to keep; a larger value corresponds to fewer vertexes kept. The range is between 0–128.

Vertex Exclusivity Width = 0

Vertex Exclusivity Width = 2

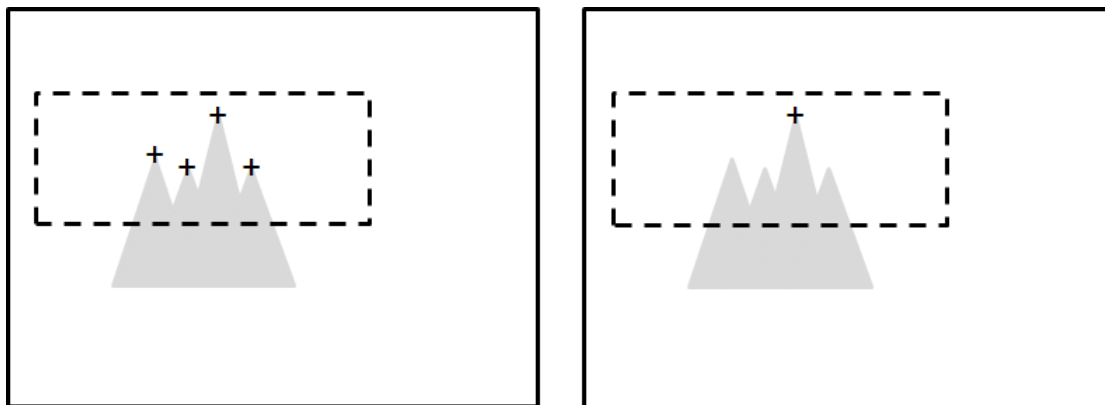

Regression Function

Specifies that the system generates a parabolic fitting curve for the detected vertexes and outputs the coordinates based on the vertex of the generated parabola.

➤ Limit

After you complete the configurations, you can view the inspection results using register images through **Test Mode**. You can then configure the upper and lower limits in the Limit dialog box. The following items can be configured for the Position Trace function.

- **Maximum Edge Position X:** specifies the upper and lower limits of the X coordinates of the maximum edge positions found by the system.
- **Maximum Edge Position Y:** specifies the upper and lower limits of the Y coordinates of the maximum edge positions found by the system.
- **Minimum Edge Position X:** specifies the upper and lower limits of the X coordinates of the minimum edge positions found by the system.
- **Minimum Edge Position Y:** specifies the upper and lower limits of the Y coordinates of the minimum edge positions found by the system.
- **Roundness:** when you enable Roundness, the system inspects the roundness of circular objects. The value specifies the upper and lower limits.

► Locate

Specifies whether the inspection region follows an inspection result by adjusting its coordinates (X, Y) and Angles (Theta). The inspection tools you can use as a reference includes Shape, Blob, Edge Position and Edge Angle. As shown in the following diagram, specific marks (such as the cross on the object) can be used for the Locate function.

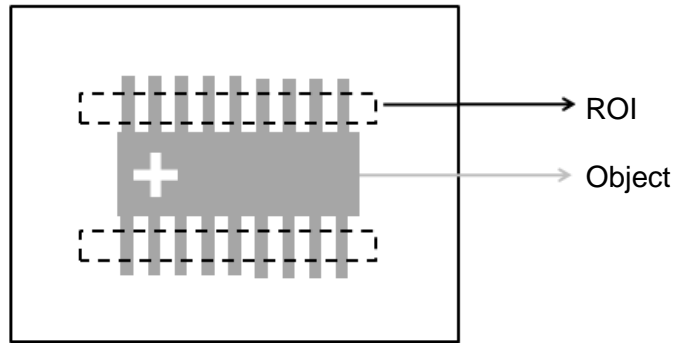

Locate Off

Locate On

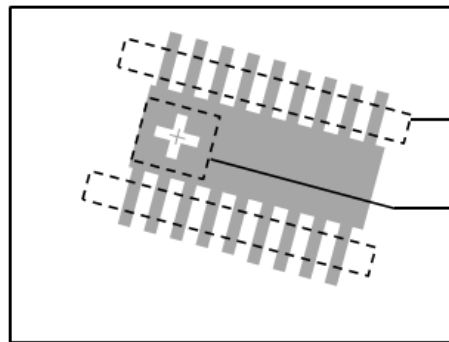
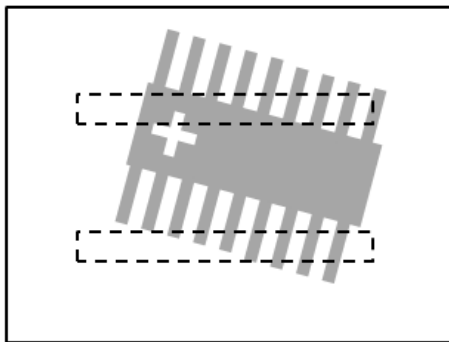

► Three tools are also provided in this item for quick configuration.

Tool

Ref. Previous Unit

Ref. Available Unit

Ref. Unit

Ref. X :	<input type="text" value="None"/>	<input type="button" value="Select"/>	<input type="button" value="CLEAR"/>
Ref. Y :	<input type="text" value="None"/>	<input type="button" value="Select"/>	<input type="button" value="CLEAR"/>
Ref. Angle :	<input type="text" value="None"/>	<input type="button" value="Select"/>	<input type="button" value="CLEAR"/>

◆ Reference Previous Unit

Selects the nearest inspection tool that can provide reference for Locate, and automatically fills in the **Ref. X**, **Ref. Y**, and **Ref. Angle** fields.

◆ Reference Available Unit

Selects the nearest unit with Locate configured, and automatically fills in the **Ref. X**, **Ref. Y**, and **Ref. Angle** fields.

◆ Reference Unit

Arbitrarily selects an inspection tool that can provide locating reference, and automatically fills in the **Ref. X**, **Ref. Y**, and **Ref. Angle** fields.

 **Reference** Please refer to Section 9.1 for detailed Location configurations.

⊙ Execute

Specifies whether to execute the inspection function in the inspection process.

➤ Always Execute

Always execute the inspection function in Run mode.

➤ Never Execute

Never execute the inspection function in Run mode.

⊙ Save

Saves all modified parameters and values.

⊙ Exit

Leaves the dialog box.

⊙ Output Item

➤ Window

Selects the output window for the total Judge result for the Position Trace tool on the designated interface.

➤ Item

- 1) **Number of Segments (N)**: outputs the total number of edges found by the Position Trace tool.
- 2) **Edge Position X (X)**: outputs the X coordinate of the assigned edge position selected in the parameters configured in the Position Trace tool.
- 3) **Edge Position (Y)**: outputs the Y coordinate of the assigned edge position selected in the parameters configured in the Position Trace tool.
- 4) **Edge Distance (D)**: outputs the distance between the assigned edge position selected in the parameters configured in the Position Trace and the edge of the fitting line/circle.
- 5) **Maximum Edge Position X (XH)**: outputs the X coordinate of the maximum edge position detected in the scanned region by the Position Trace tool.
- 6) **Minimum Edge Position X (XL)**: outputs the X coordinate of the minimum edge position detected in the scanned region by the Position Trace tool.
- 7) **Average Edge Position X (XA)**: outputs the X coordinate of the average edge position detected in the scanned region by the Position Trace tool.

- 8) **Maximum Edge Position Y (YH)**: outputs the Y coordinate of the maximum edge position detected in the scanned region by the Position Trace tool.
- 9) **Minimum Edge Position Y (YL)**: outputs the Y coordinate of the minimum edge position detected in the scanned region by the Position Trace tool.
- 10) **Average Edge Position Y (YA)**: outputs the Y coordinate of the average edge position detected in the scanned region by the Position Trace tool.
- 11) **Maximum Edge Distance (DH)**: outputs the distance between the maximum edge position found by the Position Trace tool and the edge of the fitting line/circle.
- 12) **Minimum Edge Distance (DL)**: outputs the distance between the minimum edge position found by the Position Trace tool and the edge of the fitting line/circle.
- 13) **Average Edge Distance (DA)**: outputs the distance between the average edge position found by the Position Trace tool and the edge of the fitting line/circle.
- 14) **Roundness (RD)**: when you select Ring or Arc for ROI, the system detects all edge positions on the object and regresses the roundness data.
- 15) **Circle Center Position X (CX)**: when you select Ring or Arc for ROI, the system detects all edge positions on the object and regresses the X coordinate of the center of the circle.
- 16) **Circle Center Position Y (CY)**: when you select Ring or Arc for ROI, the system detects all edge positions on the object and regresses the Y coordinate of the center of the circle.
- 17) **Circle Radius (CRU)**: outputs all radius values for circles fitting all edge positions found by the Position Trace tool.
- 18) **Vertex Position X (VTX)**: outputs the X coordinate of the assigned vertex among vertexes found by the Position Trace tool.
- 19) **Vertex Position Y (VTY)**: outputs the Y coordinate of the assigned vertex among vertexes found by the Position Trace tool.
- 20) **Vertex Pitch (VP)**: outputs the assigned pitch data among vertexes found by the Position Trace tool.
- 21) **Maximum Vertex Pitch (VPH)**: outputs the widest pitch among vertexes found by the Position Trace tool.
- 22) **Minimum Vertex Pitch (VPL)**: outputs the shortest pitch among vertexes found by the Position Trace tool.
- 23) **Position Trace ID**: outputs the ID of the inspection tool.
- 24) **Maximum Edge Position X (J) (XH)**: outputs the X coordinate of the maximum edge position found by the Position Trace tool and the results judged based on the standard configured values.
- 25) **Minimum Edge Position X (J) (XL)**: outputs the X coordinate of the minimum edge position found by the Position Trace tool and the results judged based on the standard configured values.
- 26) **Maximum Edge Position Y (J) (YH)**: outputs the Y coordinate of the maximum edge position found by the Position Trace tool and the results judged based on the standard configured values.
- 27) **Minimum Edge Position Y (J) (YL)**: outputs the Y coordinate of the minimum edge position found by the Position Trace tool and the results judged based on the standard configured values.
- 28) **Roundness (J) (RD)**: outputs the roundness data regressed using the Position Trace tool and the results judged based on the standard configured values.

5.12 Width Trace

The Width Trace tool is an advanced function of the Edge Width tool and uses identical search methods. Using ROI as an example, you can configure the search range to find multiple edges through horizontal or vertical scanning. When a segment of increased contrast is detected on the image, the tool identifies the region as an ROI. You can configure various measurement methods to inspect the maximum, minimum, and average widths of the inner and outer edges of the object.

⊙ **Algorithmic Processing**

➤ **Width Trace Scan Methods**

Selects the ROI. The ROI options provide differing edge scanning methods.

◆ The following example is for ROIs other than Ring and Arc.

Scanning direction: Horizontal

Search method: All edges

Measure method: Outside-in

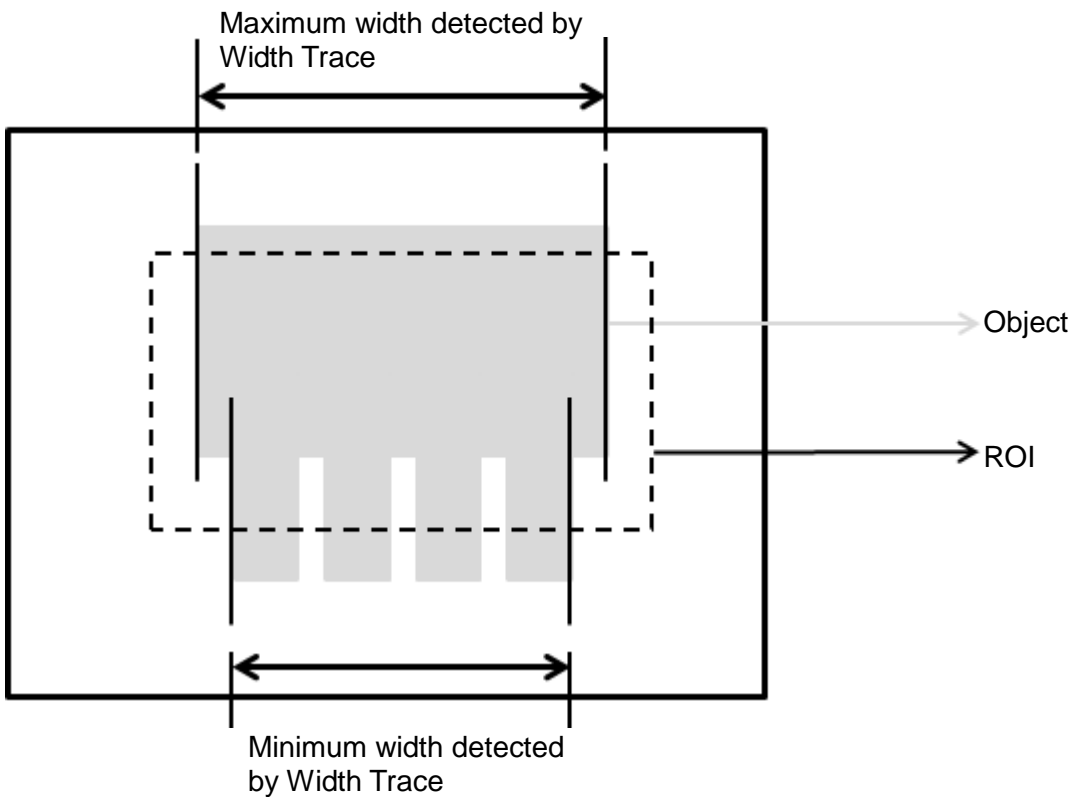

- ◆ The following example is for the Ring and Arc ROI.

Scanning direction: Outside→Center

Search method: All edges

Measure method: Outside-in

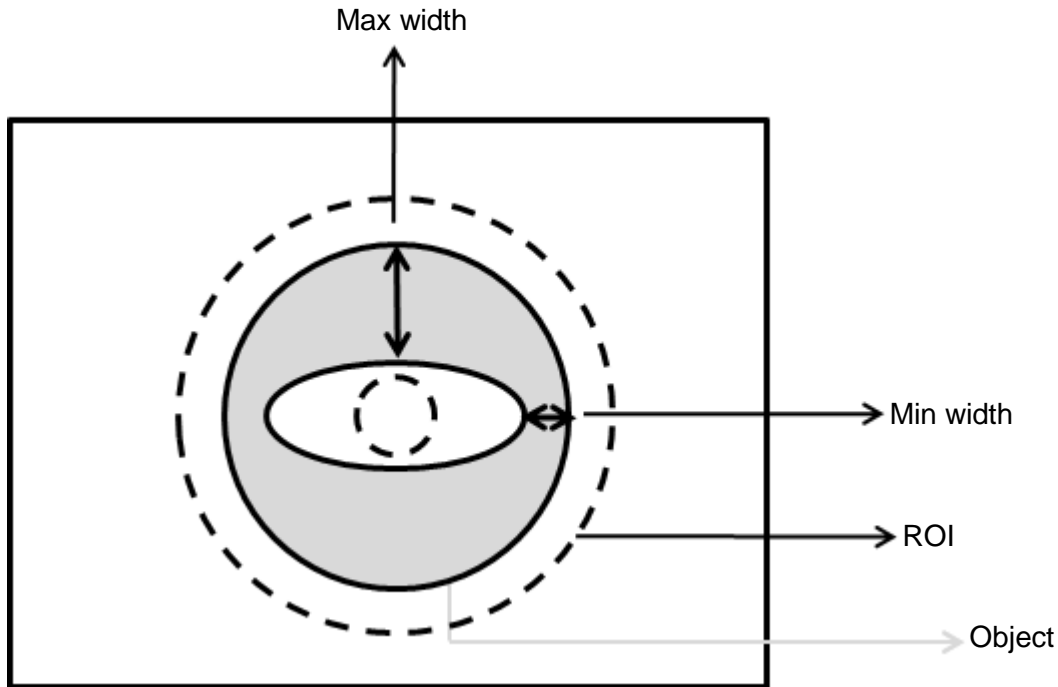

◎ Procedural Results

The Width Trace inspection tool returns the following inspection results.

- Number of Segments: outputs the total number of widths found by the Width Trace tool (unit in pixels).
- Maximum Edge Distance: outputs the maximum edge distance among all widths found by the Width Trace tool.
- Minimum Edge Distance: outputs the minimum edge distance among all widths found by the Width Trace tool.
- Average Edge Distance: outputs the average edge distance among all widths found by the Width Trace tool.
- Roundness 1: when you select Ring or Arc for the ROI, the system detects all edge positions on the inner edge of the object and 1 the Inner Circle Roundness.
- Inner Circle Position X: when you select Ring or Arc for the ROI, the system detects all edge positions on the inner edge of the object and regresses Inner Circle Position X.
- Inner Circle Position Y: when you select Ring or Arc for the ROI, the system detects all edge positions on the inner edge of the object and regresses Inner Circle Position Y.
- Inner Circle Radius: outputs all Inner Circle Radius values for circles fitting all edge positions found by the Width Trace tool on the inner circle.
- Roundness 2: when you select Ring or Arc for the ROI, the system detects all edge positions on the outer edge of the object and regresses Outer Circle Roundness.

- Outer Circle Position X: when you select Ring or Arc for the ROI, the system detects all edge positions on the outer edge of the object and regresses Outer Circle Position X.
- Outer Circle Position Y: when you select Ring or Arc for the ROI, the system detects all edge positions on the outer edge of the object and regresses Outer Circle Position Y.
- Outer Circle Radius: outputs all Outer Circle Radius values for circles fitting all edge positions found by the Width Trace tool on the outer circle.

◎ Example

- ◆ For ROIs other than Ring and Arc

Scanning direction: Vertical

Search method: All edges

Measure method: Outside-in

Inspection result: Maximum Width is 150 pixels, Minimum Width is 100 pixels, and Average Width is 125 pixels

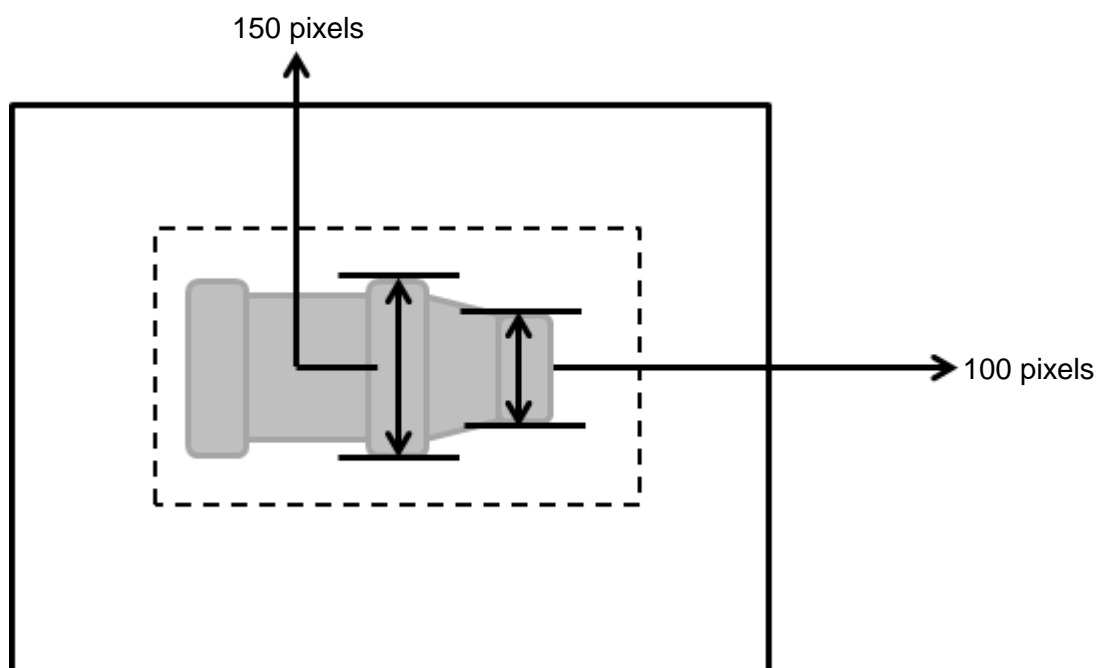

◆ For Ring and Arc ROIs

Scanning direction: Outside→Center

Search method: All edges

Measure method: Outside-in

Inspection result: Maximum Width is 100 pixels, Minimum Width is 40 pixels, and Average Width is 70 pixels

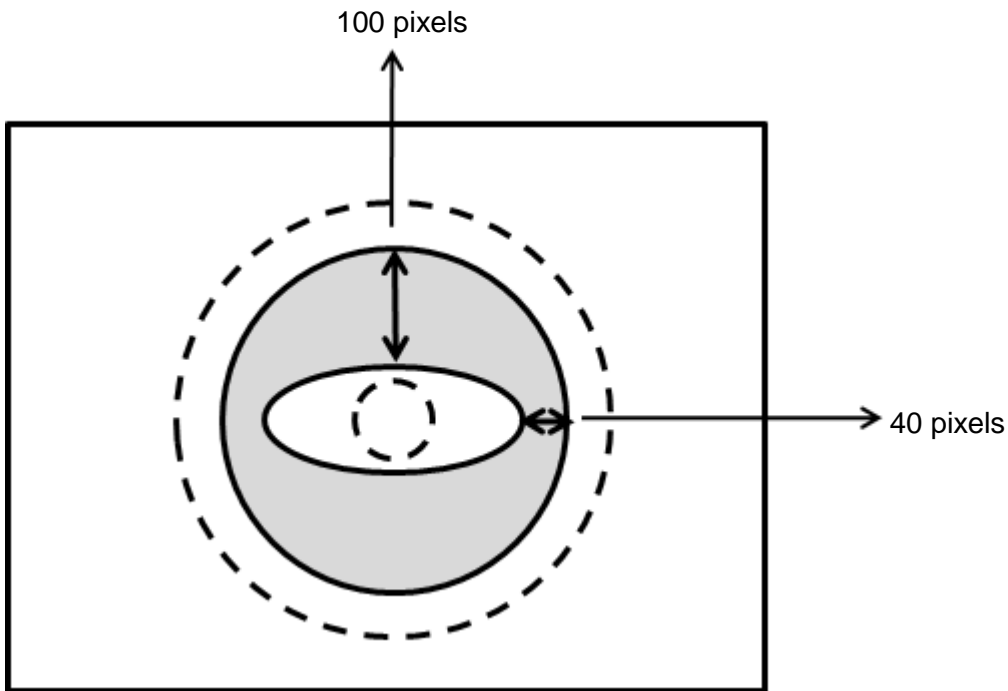

◎ Width Trace dialog box

The following picture shows the Width Trace inspection tool dialog box.

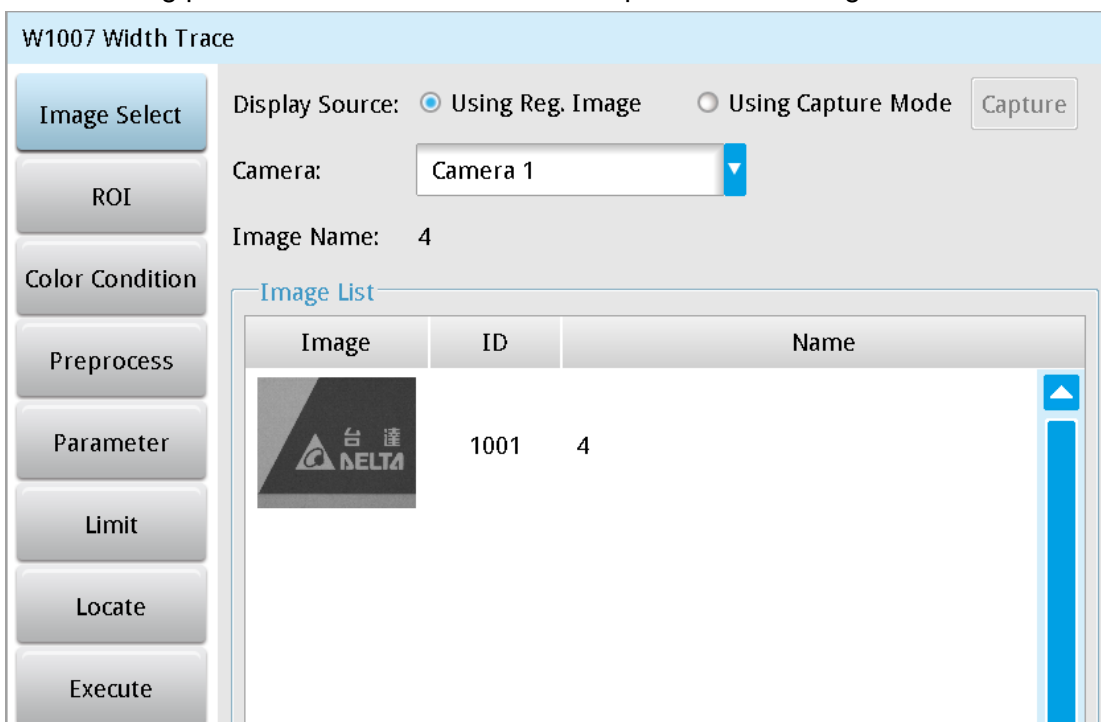

➤ **Image Select** (select Register Image)

Selects the image to be inspected from the register gallery. You can configure source cameras and inspect the image display source. When you select a different camera, the image table also switches to show the registered images acquired from that camera.

➤ **ROI** (configure detection region of interest)

Specifies the desired inspection regions to be used in the inspection. The optional ROI shapes include Rectangle, Circle, Ellipse, Ring, Arc, Polygon, and Rotated Rect. The Polygon ROI supports up to 16 points. In addition, there are up to eight mask functions to ignore particular segments.

➤ **Color Condition**

Specifies the color processing for images from a color camera: Color to Binary, Color to Grayscale, RGB grayscale, R Grayscale, G Grayscale, and B Grayscale.

➤ **Preprocess**

Specifies the image processing to apply before inspections to enhance certain aspects of the image. Preprocessing methods include Binary, Dilation, Erosion, Average, Median, Laplacian, Sobel X, Sobel Y, Sobel XY, Brightness, Contrast, Shade, and Custom (filter). You can superimpose up to six methods or create a custom method by clicking **Custom**.

➤ **Parameters**

Adjusts the Width Trace inspection tool conditions.

Direction

When you specify Ring or Arc for the ROI, you can select Center→Outside and Outside→Center for the scanning direction. For other ROI shapes, you can select Horizontal or Vertical for the scanning direction.

Look For

Specifies the search method: All Edges, Light to Dark, and Dark to Light.

Measure

Specifies the measuring method: Outside-In and Inside-Out.

Edge Strength

Specifies the threshold for the edge search (**Look For**), and you can fine-tune it between 0–100 based on the waveform displayed in the preview. When the peak is larger than the configured edge strength, **Look For** identifies the segment as an edge. As shown in the lower left picture, the system finds two edges when Edge Strength is set to 50. As shown in the lower right diagram, the system finds only one edge that is greater than the configured Edge Strength threshold of 70.

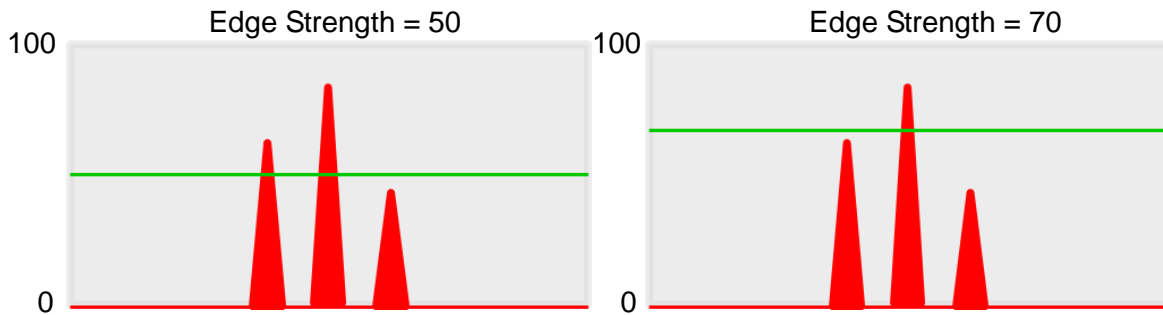

Lower

Use the Lower (limit) to filter small noise signals on the image, and the range is between 0–255. Peaks lower than the Lower value are filtered from the waveform. As shown in the lower left diagram, some noise appears when Lower is set to 0, but the noise is filtered out when Lower is set to 20.

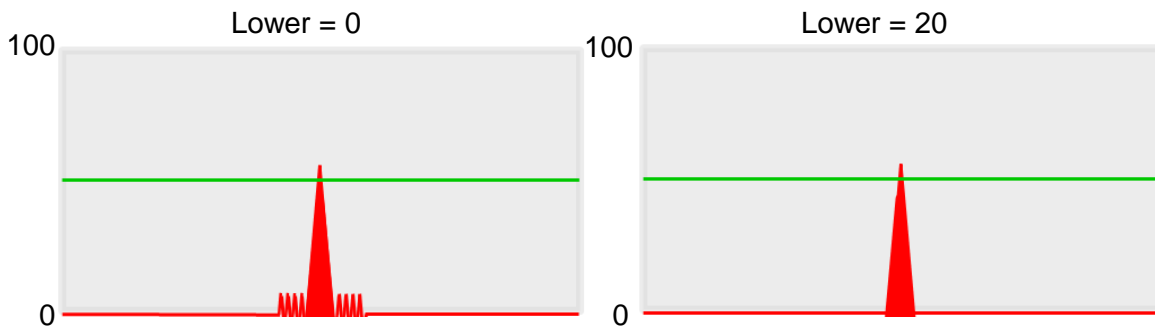

Smoothing

Sets the RGB Grayscale for edge calculations between 1–30. When you increase Smoothing, the slope of waveform changes, attenuating the effect caused by noise signals.

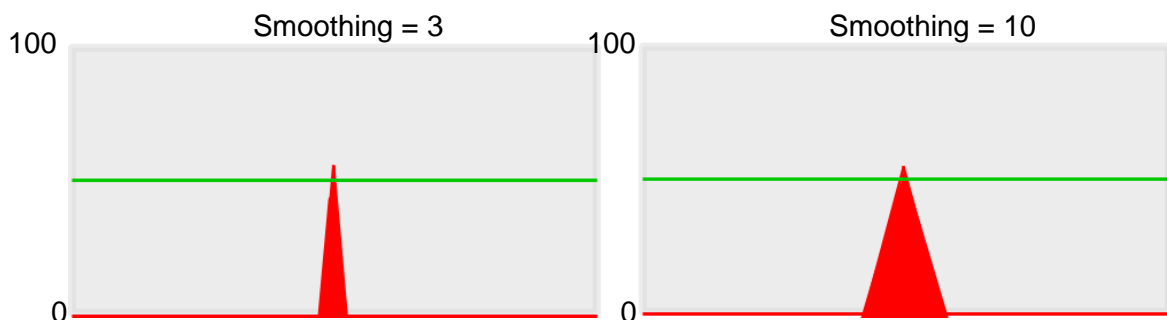

Angle

When the ROI is Ring or Arc, this sets the starting angle for the edge scan. The following pictures show starting angles of 0 and 45 degrees, respectively.

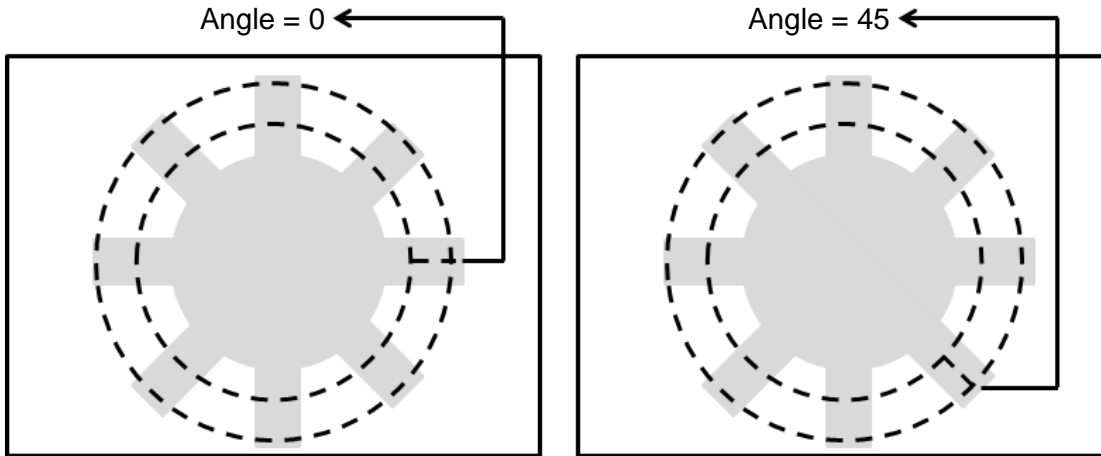

Segment Width

When you select an ROI other than Ring or Arc, the range is between 1–128. When you select Ring or Arc for the ROI, the range is between 0.1–45.0. Segment Width is the width of the horizontal pixel in each system scan.

Segment Offset

When you set Segment Width to 4 and Segment Offset to 1, the system horizontally offsets one pixel after completing each edge scan of a width of four pixels before proceeding to another four-pixel edge scan. The range is between 0.1–45.

Circle Check

➤ Circle Inspect

When you select Ring or Arc ROIs, if the object is a circle, the system constructs a fitting circle and outputs its Roundness, Inner/Outer Circle Position X, Inner/Outer Circle Position Y, and Inner/Outer Circle Radius.

➤ Origin

The position of the origin (0, 0) in System Setting is displayed on the upper left corner of the screen. You can enter new coordinates to move the origin to the new coordinates.

➤ Select

When Width Trace finds multiple widths, the system can output information for the assigned widths.

➤ Limit

After you complete the configurations, you can view the inspection results using register images through **Test Mode**. You can then configure the upper and lower limits in the Limit dialog box. The following items can be configured for the Width Trace tool.

- **Maximum Edge Distance:** specifies the upper and lower width limits identified by the tool.
- **Minimum Edge Distance:** specifies the upper and lower width limits identified by the tool.
- **Average Edge Distance:** specifies the upper and lower width limits identified by the tool.
- **Roundness 1:** when enabled, the system inspects the roundness of circular objects. This specifies the upper and lower limits of Inner Circle Roundness.
- **Roundness 2:** when enabled, the system inspects the roundness of circular objects. This specifies the upper and lower limits of Inner Circle Roundness.

➤ **Locate**

Specifies whether the inspection region follows an inspection result by adjusting its coordinates (X, Y) and Angles (Theta). The inspection tools you can use as a reference includes Shape, Blob, Edge Position and Edge Angle. As shown in the following diagram, specific marks (such as the cross on the object) can be used for the Locate function.

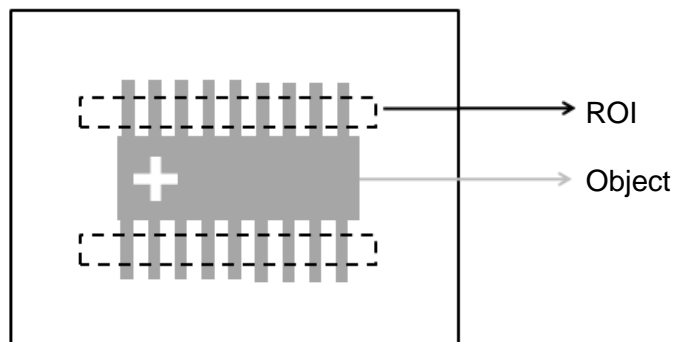

Locate Off

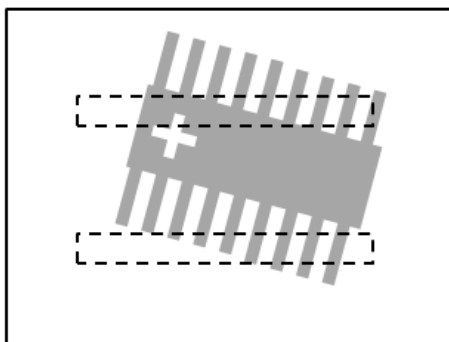

Locate On

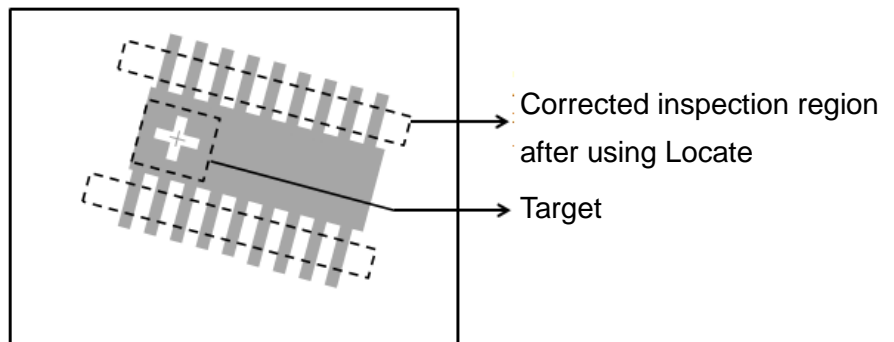

- ▶ Three tools are also provided in this item for quick configuration.

The screenshot shows a dialog box titled "Tool". At the top, there are three buttons: "Ref. Previous Unit", "Ref. Available Unit", and "Ref. Unit". Below these buttons are three rows of input fields. The first row is labeled "Ref. X:" and contains a text box with "None", a "Select" button, and a "CLEAR" button. The second row is labeled "Ref. Y:" and contains a text box with "None", a "Select" button, and a "CLEAR" button. The third row is labeled "Ref. Angle:" and contains a text box with "None", a "Select" button, and a "CLEAR" button.

◆ Reference Previous Unit

Selects the nearest inspection tool that can provide reference for Locate, and automatically fills in the **Ref. X**, **Ref. Y**, and **Ref. Angle** fields.

◆ Reference Available Unit

Selects the nearest unit with Locate configured, and automatically fills in the **Ref. X**, **Ref. Y**, and **Ref. Angle** fields.

◆ Reference Unit

Arbitrarily selects an inspection tool that can provide locating reference, and automatically fills in the **Ref. X**, **Ref. Y**, and **Ref. Angle** fields.

 **Reference** Please refer to Section 9.1 for detailed Locate configurations.

⊙ Execute

Specifies whether to execute the inspection function in the inspection process.

▶ Always Execute

Always execute the inspection function in run mode.

▶ Never Execute

Never execute the inspection function in run mode.

⊙ Save

Saves all modified parameters and values.

⊙ Exit

Leaves the dialog box.

◎ **Output Item**

➤ **Window**

Selects the total Judge result for the Width Trace tool on the designated interface.

➤ **Item**

- 1) **Number of Segments (N)**: outputs the total number of widths found by the Width Trace tool.
- 2) **Maximum Edge Distance (WH)**: outputs the maximum edge distance among all widths found by the Width Trace tool.
- 3) **Minimum Edge Distance (WL)**: outputs the minimum edge distance among all widths found by the Width Trace tool.
- 4) **Average Edge Distance (WA)**: outputs the average edge distance among all widths found by the Width Trace tool.
- 5) **Edge Width (W)**: outputs the designated width data of the plural widths identified by the Width Trace tool
- 6) **Maximum Edge Width Position X1 (HX1)**: outputs the X coordinate of the first edge of the maximum width found by the Width Trace tool.
- 7) **Maximum Edge Width Position Y1 (HY1)**: outputs the Y coordinate of the first edge of the maximum width found by the Width Trace tool.
- 8) **Maximum Edge Width Position X2 (HX2)**: outputs the X coordinate of the second edge of the maximum width found by the Width Trace tool.
- 9) **Maximum Edge Width Position Y2 (HY2)**: outputs the Y coordinate of the second edge of the maximum width found by the Width Trace tool.
- 10) **Minimum Edge Width Position X1 (LX1)**: outputs the X coordinate of the first edge of the minimum width found by the Width Trace tool.
- 11) **Minimum Edge Width Position Y1 (LY1)**: outputs the Y coordinate of the first edge of the minimum width found by the Width Trace tool.
- 12) **Minimum Edge Width Position X2 (LX2)**: outputs the X coordinate of the second edge of the minimum width found by the Width Trace tool.
- 13) **Minimum Edge Width Position Y2 (LY2)**: outputs the Y coordinate of the second edge of the minimum width found by the Width Trace tool.
- 14) **Edge Width Position X1 (XS)**: outputs the X coordinate of the first edge from the designated widths in the identified plural widths using the Width Trace tool.
- 15) **Edge Width Position Y1 (YS)**: outputs the Y coordinate of the first edge from the designated widths in the identified plural widths using the Width Trace tool.
- 16) **Edge Width Position X2 (XE)**: outputs the X coordinate of the second edge from the designated widths in the identified plural widths using the Width Trace tool.
- 17) **Edge Width Position Y2 (YE)**: outputs the Y coordinate of the second edge from the designated widths in the identified plural widths using the Width Trace tool.
- 18) **Roundness 1 (RD1)**: when you select Ring or Arc for the ROI, the system detects all edge positions on the inner edge of the object and regresses the Inner Circle Roundness.

- 19) **Inner Circle Position X (CX1)**: when you select Ring or Arc for the ROI, the system detects all edge positions on the inner edge of the object and regresses the Inner Circle Position X.
- 20) **Inner Circle Position Y (CY1)**: when you select Ring or Arc for the ROI, the system detects all edge positions on the inner edge of the object and regresses the Inner Circle Position Y.
- 21) **Inner Circle Radius (CR1)**: outputs all Inner Circle Radius values for circles fitting all edge positions found by the Width Trace tool on the inner circle.
- 22) **Roundness 2 (RD2)**: when you select Ring or Arc for the ROI, the system detects all edge positions on the outer edge of the object and regresses the Outer Circle Roundness.
- 23) **Outer Circle Position X (CX2)**: when you select Ring or Arc for the ROI, the system detects all edge positions on the outer edge of the object and regresses the Outer Circle Position X.
- 24) **Outer Circle Position Y (CY2)**: when you select Ring or Arc for the ROI, the system detects all edge positions on the outer edge of the object and regresses the Outer Circle Position Y.
- 25) **Outer Circle Radius (CR2)**: outputs all Outer Circle Radius values for circles fitting all edge positions found by the Width Trace tool on the outer circle.
- 26) **Width Trace ID**: outputs the ID of the inspection tool.
- 27) **Maximum Edge Distance (J) (WH)**: outputs the maximum edge distance determined (Judge result) among all widths found by the Width Trace tool.
- 28) **Minimum Edge Distance (J) (WL)**: outputs the minimum edge distance determined (Judge result) among all widths found by the Width Trace tool.
- 29) **Average Edge Distance (J) (WA)**: outputs the average edge distance determined (Judge result) among all widths found by the Width Trace tool.
- 30) **Roundness 1 (J) (RD1)**: outputs the Inner Circle Roundness data regressed using the Width Trace tool and the results judged based on the standard configured values.
- 31) **Roundness 2 (J) (RD2)**: outputs the Outer Circle Roundness data regressed using the Width Trace tool and the results judged based on the standard configured values.

5.13 OCV

The OCV tool uses Optical Character Verification to compare characters and search the ROI using font outlines to detect characters. Each character is then automatically or manually divided and added to the dictionary. All subsequent objects in the ROI that are potentially characters are compared to the characters in the dictionary. The tool then recognizes characters matching the characters in the dictionary when there is a high degree of similarity.

◎ **Algorithmic Processing**

➤ OCV Scanning Methods

The OCV tool supports only one type of ROI: Rectangular.

Custom: Disable

Verification Mode: Smart

Word Direction: Left to Right

Detect Word: Black

Row Number 1

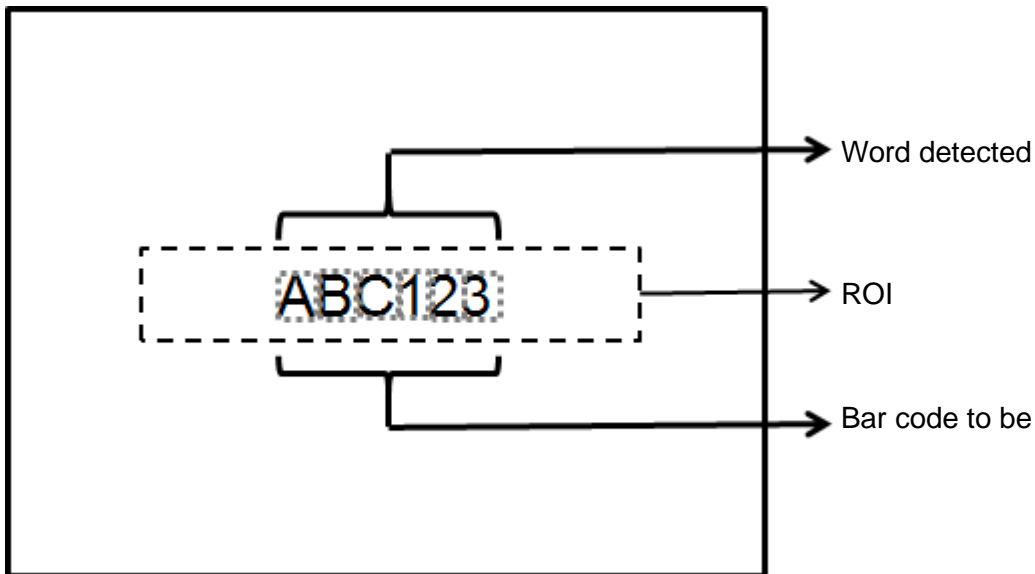

Custom: Disable

Verification Mode: Smart

Word Direction: Left to Right

Detect Word: White

Row Number 2

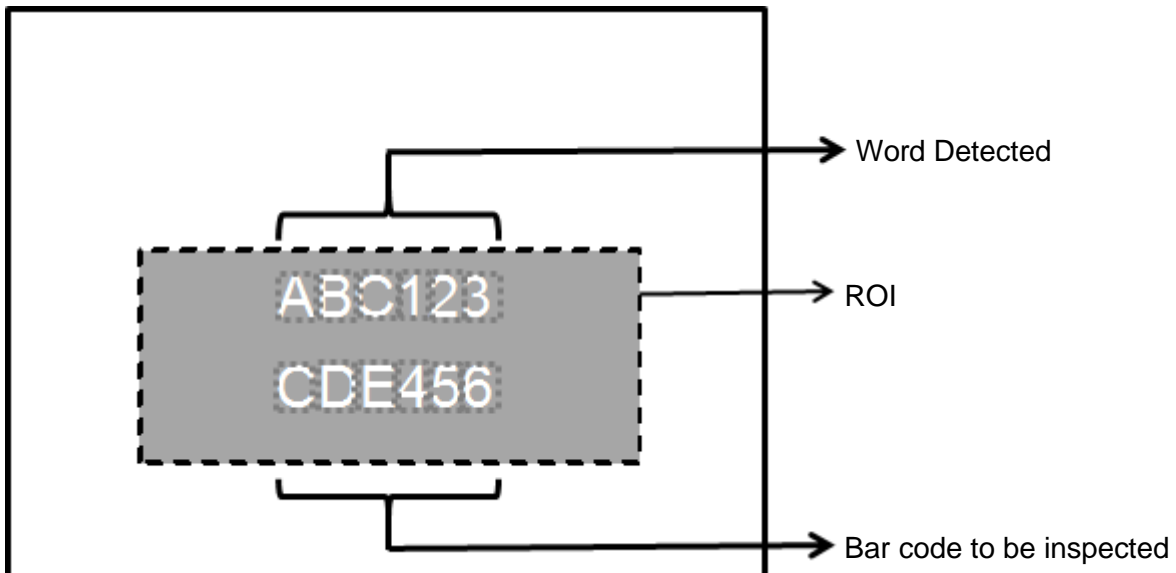

© **Procedural Results**

The OCV tool returns the following inspection results.

- **High:** outputs the total number of words detected by the OCV tool.
- **Row1 Number of Characters:** outputs the number of characters in the first row detected and recognized by the OCV tool in the ROI.
- **Row2 Number of Characters:** outputs the number of characters in the second row detected and recognized by the OCV tool in the ROI.
- **Row1 Maximum X:** outputs the largest X coordinate in all characters found by the OCV tool in the strings in the first row.
- **Row1 Maximum Y:** outputs the largest Y coordinate in all characters found by the OCV tool in the strings in the first row.
- **Row1 Minimum X:** outputs the smallest X coordinate in all characters found by the OCV tool in the strings in the first row.
- **Row1 Minimum Y:** outputs the smallest Y coordinate in all characters found by the OCV tool in the strings in the first row.
- **Row2 Maximum X:** outputs the largest X coordinate in all characters found by the OCV tool in the strings in the second row.
- **Row2 Maximum Y:** outputs the largest Y coordinate in all characters found by the OCV tool in the strings in the second row.
- **Row2 Minimum X:** outputs the smallest X coordinate in all characters found by the OCV tool in the strings in the second row.
- **Row2 Minimum Y:** outputs the smallest Y coordinate in all characters found by the OCV tool in the strings in the second row.
- **Row1 Maximum Similarity:** outputs the value of the highest degree of character similarity among all characters found by the OCV tool in the strings in the first row.
- **Row1 Minimum Similarity:** outputs the value of the lowest degree of character similarity among all characters found by the OCV tool in the strings in the first row.
- **Row2 Maximum Similarity:** outputs the value of the highest degree of character similarity among all characters found by the OCV tool in the strings in the second row.
- **Row2 Minimum Similarity:** outputs the value of the lowest degree of character similarity among all characters found by the OCV tool in the strings in the second row.

◎ Example

The OCV tool selects the text to be inspected in the rectangular ROI, and then show the detected text using yellow outlines.

Custom: Disable

Verification Mode: Smart

Word Direction: Left to Right

Detect Word: Black

Row Number: 1

Inspection result: ABC123

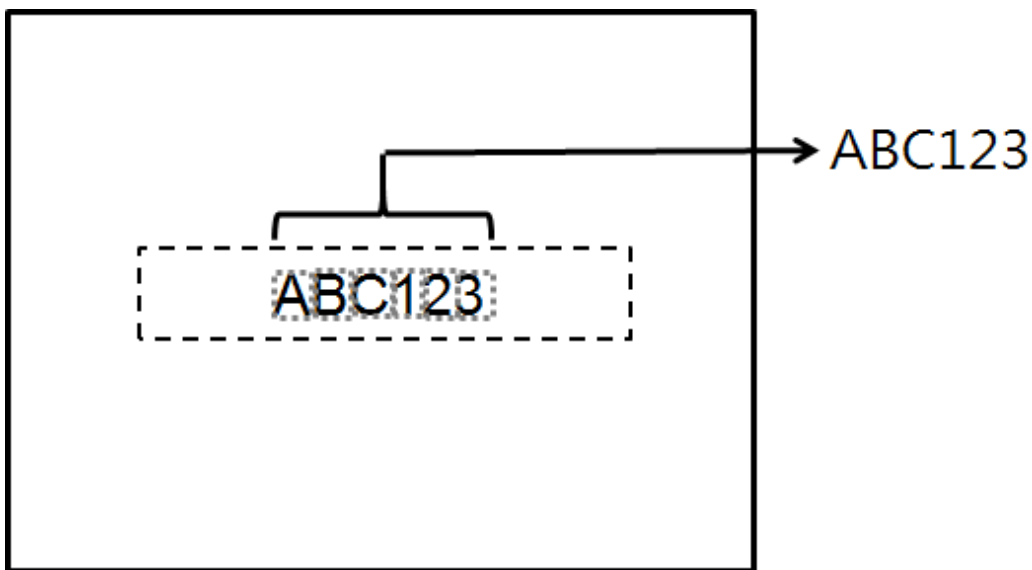

◎ OCV dialog box

The following picture shows the OCV inspection tool dialog box.

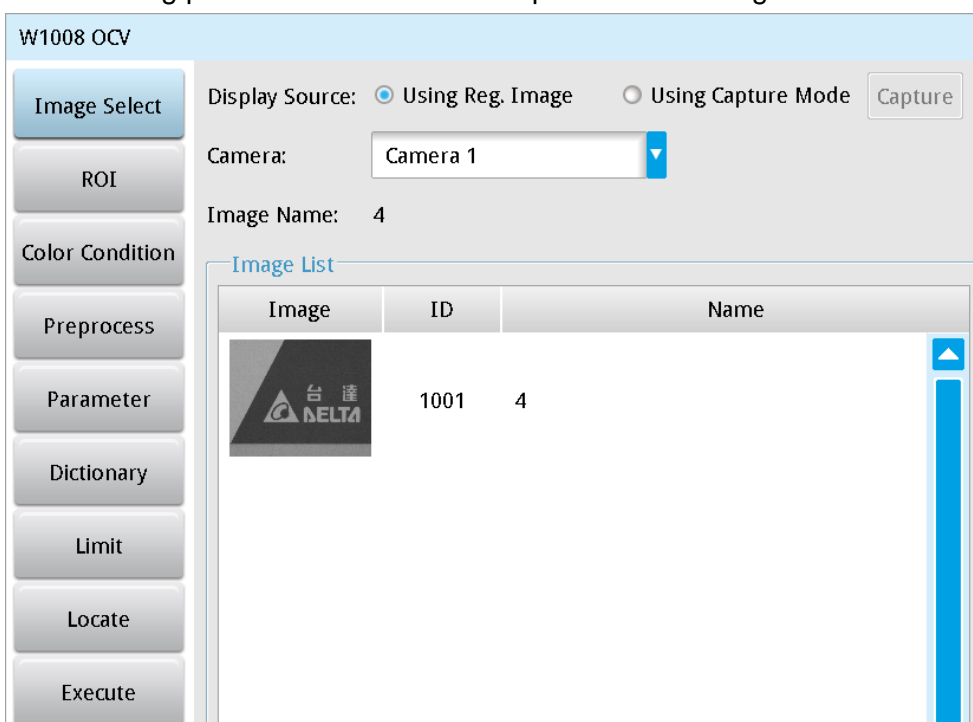

➤ **Image Select** (select Register Image)

Selects the image to be inspected from the register gallery. You can configure source cameras and inspect the image display source. When you select a different camera, the image table also switches to show the registered images acquired from that camera.

➤ **ROI** (configure detection region of interest)

Specifies the ROI. The only ROI available for OCV is Rectangle. Up to 8 mask functions are also provided for ignoring unwanted segments.

➤ **Color Condition**

Specifies the color processing for images from a color camera: Color to Binary, Color to Grayscale, RGB grayscale, R Grayscale, G Grayscale, and B Grayscale.

➤ **Preprocess**

Specifies the image processing to apply before inspections to enhance certain aspects of the image. Preprocessing methods include Binary, Dilation, Erosion, Average, Median, Laplacian, Sobel X, Sobel Y, Sobel XY, Brightness, Contrast, Shade, and Custom (filter). You can superimpose up to six methods or create a custom method by clicking **Custom**.

➤ **Parameters**

Adjusts the OCV inspection tool conditions.

Verification Mode

Custom

Determines whether to enable manual selection of each independent character. If you select **Disable**, the system automatically detects and selects characters.

Character Cutting Setting

When you select **On** for **Custom**, you can configure the selection of independent characters.

Verification Mode

When you select **Off** for **Custom**, you can choose the optional identification mode: Smart and Strengthen.

Word Direction

Specifies the character search direction: Left to Right, Right to Left, Up to Down, and Down to Up.

Detect Word

Two conditions may arise when detecting characters. These conditions are black characters on a white background and white characters on a black background. Specifies whether to read black or white characters in gray scale images.

Row Number

Specifies the number of rows of strings to be detected in the ROI (1–2 rows).

Tilt Correction

Specifies whether to correct character tilt to improve character recognition when characters appear tilted.

Wave Strengthen

Specifies whether to strengthen character separation when characters are close together. The options are None, Low, Medium, High.

1st Row

Specifies the length of the string to be detected in the first row of strings (1–22).

2nd Row

Specifies the length of the string to be detected in the second row of strings (1–22).

Level

Specifies level for recognizing a character when you select **Strengthen** for **Verification Mode**. You can set Level between 0–100 based on the waveform displayed in the preview. When the wave is larger than the configured Level, the OCV tool identifies the segment as a character. As shown in the lower left diagram, the system finds two characters when Level is set to 50. As shown in the lower right diagram, the system finds only one character when Level is set to 70.

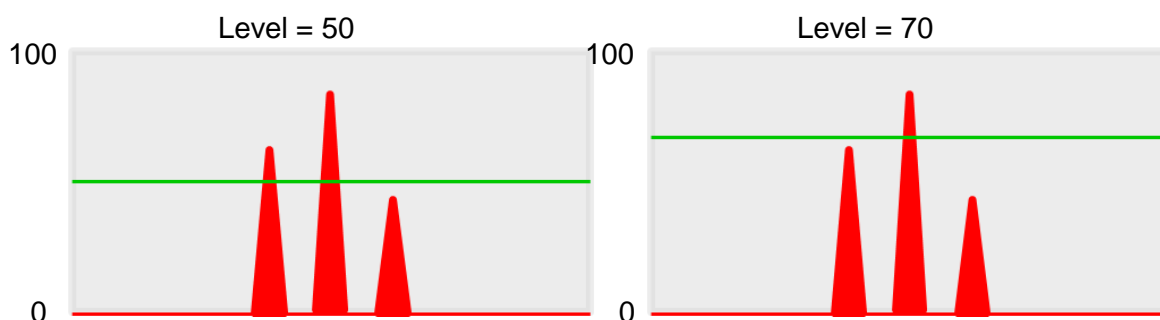
**String Adjust**

- ◆ **Threshold:** specifies the threshold for recognizing an object as a string. When this string is poorly separated, you can lower this parameter to improve the accuracy of string separation.
- ◆ **Lower:** specifies the filter to remove fine noise from images (0–100). Waves smaller than this value disappear from the waveform.
- ◆ **Minimum Width:** specifies the minimum width of a single character.
- ◆ **Maximum Width:** specifies the maximum width of a single character.
- ◆ **Smoothing:** specifies the RGB Grayscale for edges (0–10) for calculations. When you increase Smoothing, it changes the slope of the waveform, thereby attenuating the effect of noise in the signal.

Word Adjust Row1

- ◆ **Threshold:** specifies the minimum threshold for recognizing characters in a string. When a string is poorly separated, you can lower this value to improve the accuracy of string separation.
- ◆ **Lower:** specifies the lower (limit) to filter small noise from the signal (0–100). Waves less than this value disappear from the waveform.
- ◆ **Minimum Width:** specifies the minimum width of a single character.
- ◆ **Maximum Width:** specifies the maximum width of a single character.
- ◆ **Smoothing:** specifies the RGB Grayscale for edges (0–10) for calculations. When you increase Smoothing, it changes the slope of the waveform, thereby attenuating the effect of noise in the signal.

Word Adjust Row2

- ◆ **Threshold:** specifies the minimum threshold for recognizing characters in a string. When a string is poorly separated, you can lower this value to improve the accuracy of string separation.
- ◆ **Lower:** specifies the lower (limit) to filter small noise from the signal (0–100). Waves less than this value disappear from the waveform.
- ◆ **Minimum Width:** specifies the minimum width of a single character.
- ◆ **Maximum Width:** specifies the maximum width of a single character.
- ◆ **Smoothing:** specifies the RGB Grayscale for edges (0–10) for calculations. When you increase Smoothing, it changes the slope of the waveform, thereby attenuating the effect of noise in the signal.

➤ Origin

The position of the origin (0, 0) in System Setting is displayed on the upper left corner of the screen. You can enter new coordinates to move the origin to the new coordinates.

► Dictionary

Registers a single word or an entire string in the Dictionary.

Dictionary

Word Set Source: SD Card 1 Dictionary Index: 0 ▼

Registered Wrods	0	Word(s)		
Number	10	Class	0	Word(s)
Uppercase	26	Class	0	Word(s)
Lowercase	26	Class	0	Word(s)
Sign	1	Class	0	Word(s)
Free Words	200	Word(s)		

Word Register

Dictionary Index

You can create a maximum of 10 dictionaries.

Word Register

Specifies settings related to registering characters.

Word Register

Detail Setup

Word Set Source: SD Card 1 Dictionary Index: 0

		Number of Characters								
		0	1	2	3	4	5	6	7	8
Character	0									
	1									
	2									
	3									
	4									
	5									
	6									
	7									
	8									
	9									

Character String1 String2

Enable Disable Delete Delete All

Exit

◆ Character

Registers characters in the dictionary. If the first detected character is "A", then set **Character Selection** to 1, fill in "A" in the **Character** item and then click **OK**. This registers the first character.

◆ String1

Registers the first string. Enter the contents of the first string, and click **OK**.

◆ String2

Registers the second string. Enter the contents of the second string, and click **OK**.

◆ Enable

When the dictionary stores characters not in use, this selects and activates the characters in the dictionary on the left side. Select the characters from the dictionary on the left side and click **Enable** to include them in the search reference.

◆ Disable

Excludes characters from the search reference when some of the enabled characters in the dictionary are not wanted as search reference. Select the characters from the dictionary on the left side and click **Disable** to exclude them from the search reference.

◆ Delete

Deletes characters from the dictionary. Select the characters from the dictionary on the left side and click **Delete** to delete them from the dictionary.

◆ Delete All

Deletes all the characters in the dictionary. Click **Delete All** to clear the dictionary.

➤ Restrictions

After you complete the configurations, you can view the inspection results using register images through **Test Mode**. You can then configure the upper and lower limits in the Limit dialog box. You can configure the following items for the OCV tool.

1st Row String**◆ String Content**

Specifies the format for the string: Normal or Date.

◆ String Content1

Specifies the content for the standard string for comparison. The format is limited to English letters, numbers, and some punctuation characters.

◆ Similarity Limit

This configures the similarity inspection between the current string and the standard string.

2nd Row String**◆ String Content**

Specifies the format for the string: **Normal** or **Date**.

◆ String Content1

Specifies the content for the standard string for comparison. The format is limited to English letters, numbers, and some punctuation characters.

◆ Similarity Limit

Specifies the similarity inspection between the current string and the standard string.

► Locate

Specifies whether the inspection region follows an inspection result by adjusting its coordinates (X, Y) and Angles (Theta). The inspection tools you can use as a reference includes Shape, Blob, Edge Position and Edge Angle. As shown in the following diagram, specific marks (such as the cross on the object) can be used for the Locate function.

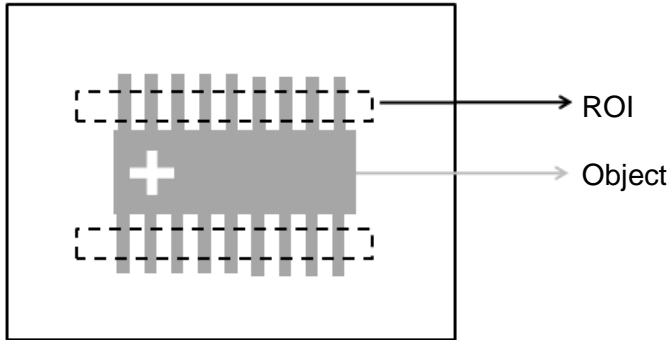

Locate Off

Locate On

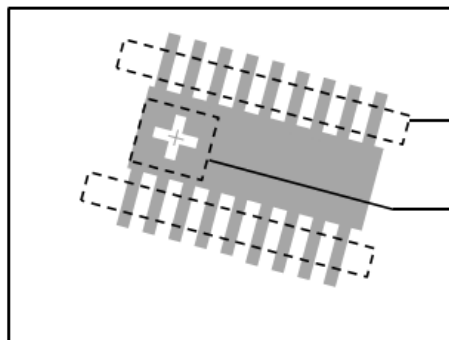
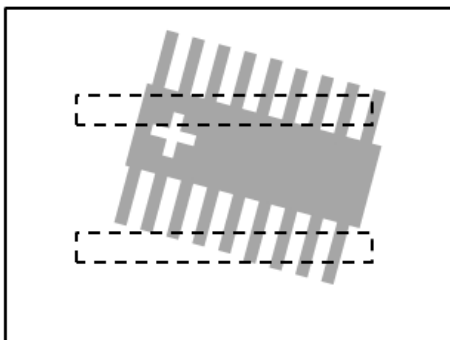

► Three tools are also provided in this item for quick configuration.

Tool

Ref. Previous Unit	Ref. Available Unit	Ref. Unit
--------------------	---------------------	-----------

Ref. X :

Ref. Y :

Ref. Angle :

◆ Reference Previous Unit

Selects the nearest inspection tool that can provide reference for Locate, and automatically fills in the **Ref.**

X, **Ref. Y**, and **Ref. Angle** fields.

◆ **Reference Available Unit**

Selects the nearest unit with Locate configured, and automatically fills in the **Ref. X**, **Ref. Y**, and **Ref. Angle** fields.

◆ **Reference Unit**

Arbitrarily selects an inspection tool that can provide locating reference, and automatically fills in the **Ref. X**, **Ref. Y**, and **Ref. Angle** fields.

 **Reference** Please refer to Section 9.1 for detailed Locate configurations.

⊙ **Execute**

Specifies whether to execute the inspection function in the inspection process.

➤ **Always Execute**

Always execute the inspection function in Run mode.

➤ **Never Execute**

Never execute the inspection function in Run mode.

⊙ **Save**

Saves all modified parameters and values.

⊙ **Exit**

Leave the dialog box.

⊙ **Output Item**

➤ **Window**

Selects the output window for the total Judge result for the OCV inspection tool on the designated interface.

➤ **Item**

- 1) **High (N)**: outputs the total number of words detected by the OCV tool.
- 2) **Row1 Number of Characters (R1N)**: outputs the total number of characters identified by the OCV tool in the first row.
- 3) **Row2 Number of Characters (R2N)**: outputs the total number of characters identified by the OCV tool in the second row.
- 4) **Row1 Start X of Character (X1S)**: outputs the starting X coordinate of the designated character found by the OCV tool in the strings in the first row.
- 5) **Row1 End X of Character (X1E)**: outputs the ending X coordinate of the designated character found by the OCV tool in the strings in the first row.
- 6) **Row1 Start Y of Character (Y1S)**: outputs the starting Y coordinate of the designated character found by the OCV tool in the strings in the first row.

- 7) **Row1 End Y of Character (Y1E)**: outputs the ending Y coordinate of the designated character found by the OCV tool in the strings in the first row.
- 8) **Row1 Identified Result (C1)**: outputs the result of the designated character found by the OCV tool in the strings in the first row.
- 9) **Row1 Similarity of Character (S1)**: outputs the degree of similarity of the designated character found by the OCV tool in the strings in the first row.
- 10) **Row2 Start X of Character (X2S)**: outputs the starting X coordinate of the designated character found by the OCV tool in the strings in the second row.
- 11) **Row2 End X of Character (X2E)**: outputs the ending X coordinate of the designated character found by the OCV tool in the strings in the second row.
- 12) **Row2 Start Y of Character (Y2S)**: outputs the starting Y coordinate of the designated character found by the OCV tool in the strings in the second row.
- 13) **Row2 End Y of Character (Y2E)**: outputs the ending Y coordinate of the designated character found by the OCV tool in the strings in the second row.
- 14) **Row2 Identified Result (C2)**: outputs the result of the designated character found by the OCV tool in the strings in the second row.
- 15) **Row2 Similarity of Character (S2)**: outputs the degree of similarity of the designated character found by the OCV tool in the strings in the second row.
- 16) **Row1 Maximum X (X1H)**: outputs the largest X coordinate in all characters found by the OCV tool in the strings in the first row.
- 17) **Row1 Maximum Y (Y1H)**: outputs the largest Y coordinate in all characters found by the OCV tool in the strings in the first row.
- 18) **Row1 Minimum X (X1L)**: outputs the smallest X coordinate in all characters found by the OCV tool in the strings in the first row.
- 19) **Row1 Minimum Y (Y1L)**: outputs the smallest Y coordinate in all characters found by the OCV tool in the strings in the first row.
- 20) **Row2 Maximum X (X2H)**: outputs the largest X coordinate in all characters found by the OCV tool in the strings in the second row.
- 21) **Row2 Maximum Y (Y2H)**: outputs the largest Y coordinate in all characters found by the OCV tool in the strings in the second row.
- 22) **Row2 Minimum X (X2L)**: outputs the smallest X coordinate in all characters found by the OCV tool in the strings in the second row.
- 23) **Row2 Minimum Y (Y2L)**: outputs the smallest Y coordinate in all characters found by the OCV tool in the strings in the second row.
- 24) **Row1 Maximum Similarity (S1H)**: outputs the value of the highest degree of character similarity among all characters found by the OCV tool in the strings in the first row.
- 25) **Row1 Minimum Similarity (S1L)**: outputs the value of the lowest degree of character similarity among all characters found by the OCV tool in the strings in the first row.
- 26) **Row2 Maximum Similarity (S2H)**: outputs the value of the highest degree of character similarity among all characters found by the OCV tool in the strings in the second row.

- 27) **Row2 Minimum Similarity (S2L)**: outputs the value of the lowest degree of character similarity among all characters found by the OCV tool in the strings in the second row.
- 28) **OCV String1 (R1)**: outputs the result obtained by the OCV tool in the strings in the first row.
- 29) **OCV String2 (R2)**: outputs the result obtained by the OCV tool in the strings in the second row.
- 30) **OCV ID**: outputs the ID of the inspection tool.
- 31) **OCV String1 (J) (R1)**: outputs the character contents obtained by the OCV tool in the strings in the first row and logical results (Judge) based on the standard configured values.
- 32) **OCV String2 (J) (R2)**: outputs the character contents obtained by the OCV tool in the strings in the second row and logical results (Judge) based on the standard configured values.
- 33) **Row1 Similarity of Character (J) (R1S)**: outputs the degree of similarity of the designated character found by the OCV tool in the strings in the first row and logical results (Judge) based on the standard configured values.
- 34) **Row2 Similarity of Character (J) (R2S)**: outputs the degree of similarity of the designated character found by the OCV tool in the strings in the second row and logical results (Judge) based on the standard configured values.

5.14 Bar Code

The Bar Code inspection tool reads 1D bar codes by searching for valid 1D bar codes in the ROI. It then decodes and outputs the result. This tool supports Code 39, Code 93, Code 128, I25, EAN8, UPCE, ISBN 10, UPCA, EAN13, ISBN 13, and Delta's custom DAH Code.

© **Algorithmic Processing**

➤ **Bar Code Scanning Methods**

The Bar Code tool supports only one type of ROI: Rectangular.

Type: Auto Detect

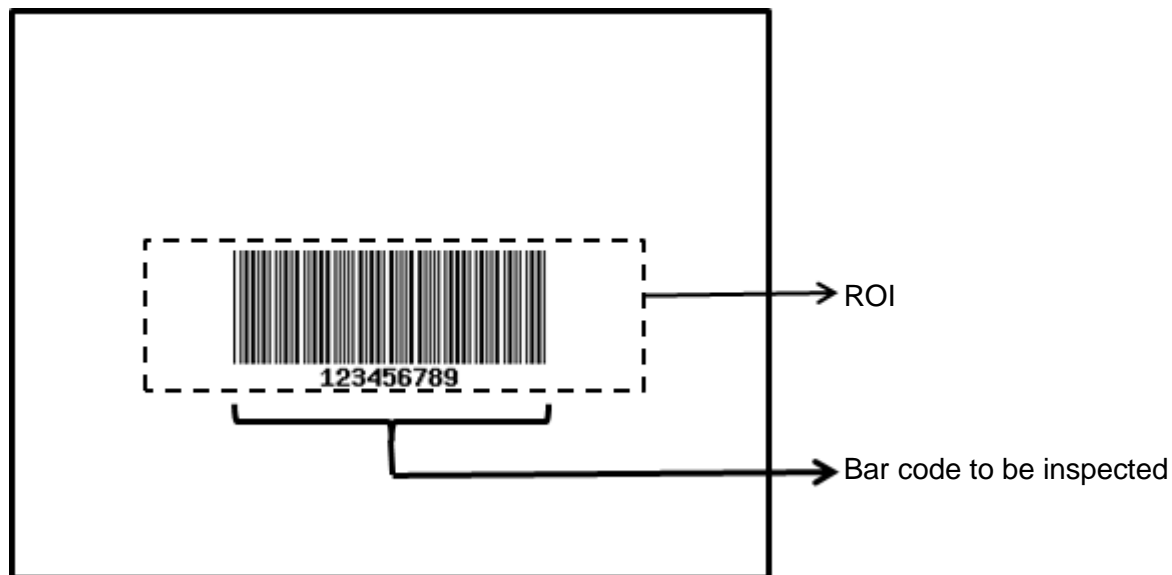

© **Procedural Results**

The Bar Code tool returns the following inspection results.

- Type: after completing inspections, outputs the type ID to this field. The following table lists the type IDs.

Serial No.	Barcode Type
0	No barcode
1	CODE39
2	CODE93
3	CODE128
4	I25
5	EAN8
6	UPCE
7	ISBN10
8	UPCA
9	EAN13
10	ISBN13
11	DAH CODE

© **Example**

Select the bar code to be inspected using the Rectangular ROI and the tool displays the inspection result above the bar code.

Type: Auto Detect

Inspection result: 123456789

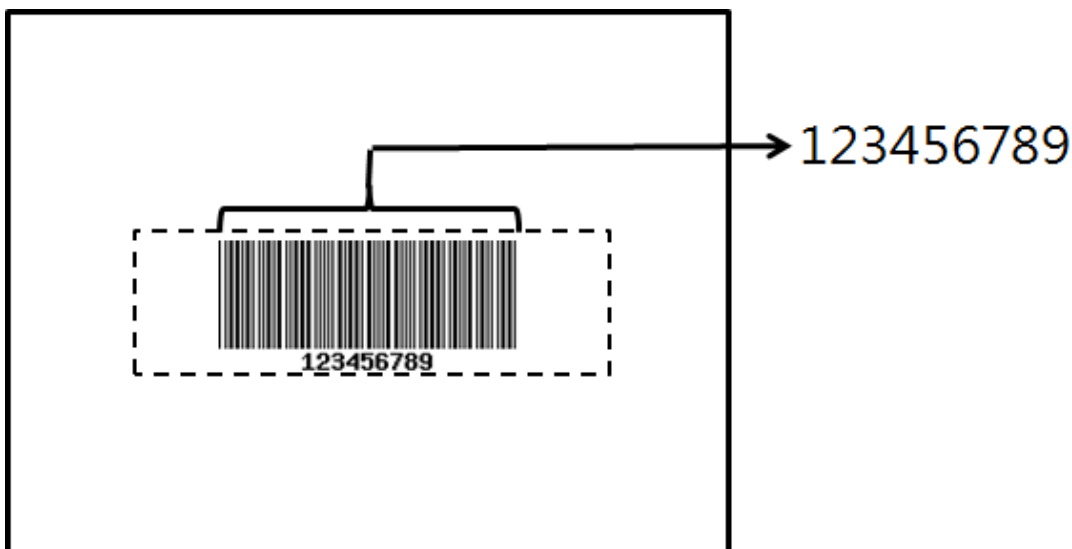

◎ Bar Code dialog box

The following picture shows the Bar Code inspection tool dialog box.

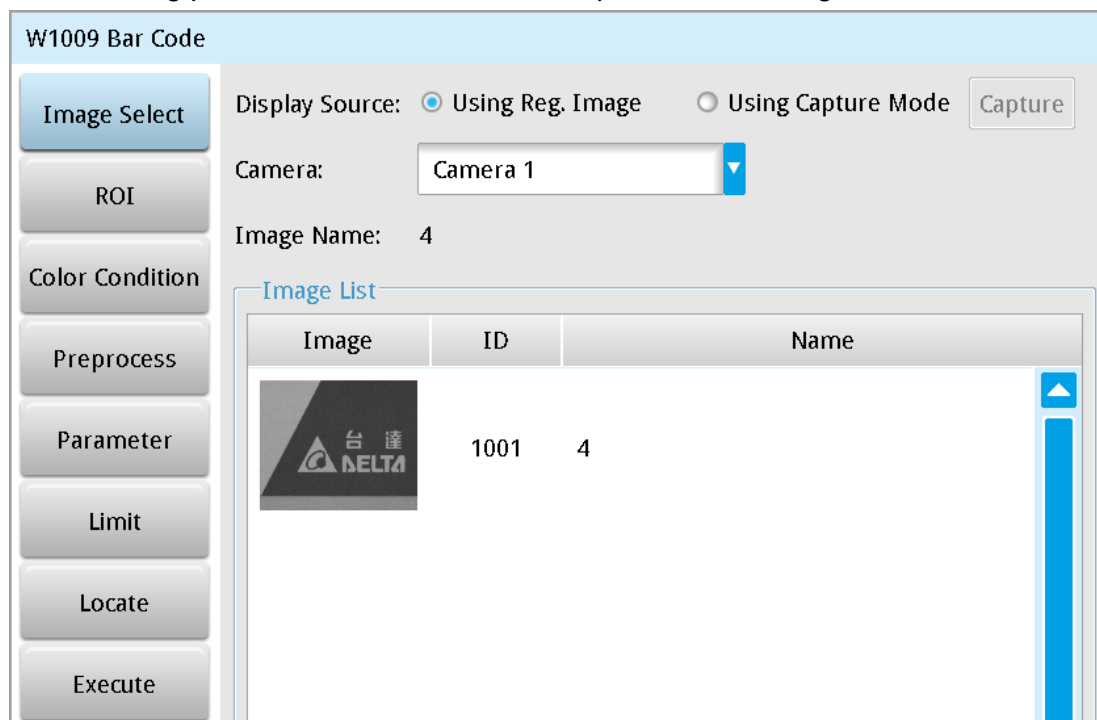

➤ Image Select (select Register Image)

Selects the image to be inspected from the register gallery. You can configure source cameras and inspect the image display source. When you select a different camera, the image table also switches to show the registered images acquired from that camera.

➤ ROI (configure detection region of interest)

Specifies the desired inspection regions to be used in the inspection. The only ROI available for the Bar Code tool is Rectangle. Up to 8 mask functions are also provided for ignoring unwanted segments.

➤ Color Condition

Specifies the color processing for images from a color camera: Color to Binary, Color to Grayscale, RGB grayscale, R Grayscale, G Grayscale, and B Grayscale.

➤ Preprocess

Specifies the image processing to apply before inspections to enhance certain aspects of the image. Preprocessing methods include Binary, Dilation, Erosion, Average, Median, Laplacian, Sobel X, Sobel Y, Sobel XY, Brightness, Contrast, Shade, and Custom (filter). You can superimpose up to six methods or create a custom method by clicking **Custom**.

► Parameters

Adjusts the Bar Code inspection tool conditions.

Type

Specifies the type of Bar Code to read. Options include Code 39, Code 93, Code 128, I25, EAN8, UPCE, ISBN 10, UPCA, EAN13, ISBN 13, and Delta's custom DAH Code. You can also select Auto Detect for automatic bar code type determination.

Origin

The position of the origin (0, 0) in System Setting is displayed on the upper left corner of the screen. You can enter new coordinates to move the origin to the new coordinates.

► Restrictions

After acquiring inspection results, you can view the inspection results and configure the correct bar code contents to determine whether the result qualifies.

► Locate

Specifies whether the inspection region follows an inspection result by adjusting its coordinates (X, Y) and Angles (Theta). The inspection tools you can use as a reference includes Shape, Blob, Edge Position and Edge Angle. As shown in the following diagram, specific marks (such as the cross on the object) can be used for the Locate function.

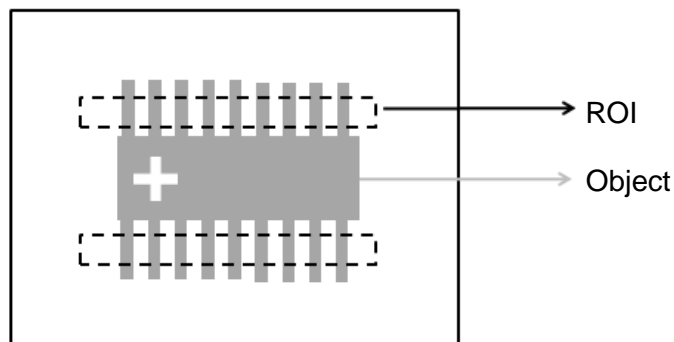

Locate Off

Locate On

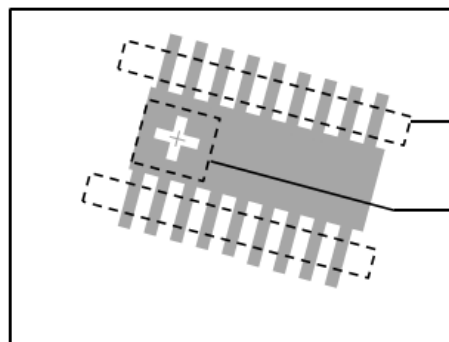
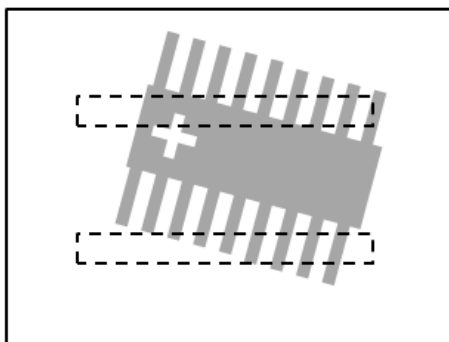

- ▶ Three tools are also provided in this item for quick configuration.

The screenshot shows a dialog box titled "Tool". At the top, there are three buttons: "Ref. Previous Unit", "Ref. Available Unit", and "Ref. Unit". Below these buttons are three rows of input fields. The first row is labeled "Ref. X:" and contains a text box with "None", a "Select" button, and a "CLEAR" button. The second row is labeled "Ref. Y:" and contains a text box with "None", a "Select" button, and a "CLEAR" button. The third row is labeled "Ref. Angle:" and contains a text box with "None", a "Select" button, and a "CLEAR" button.

◆ Reference Previous Unit

Selects the nearest inspection tool that can provide reference for Locate, and automatically fills in the **Ref. X**, **Ref. Y**, and **Ref. Angle** fields.

◆ Reference Available Unit

Selects the nearest unit with Locate configured, and automatically fills in the **Ref. X**, **Ref. Y**, and **Ref. Angle** fields.

◆ Reference Unit

Arbitrarily selects an inspection tool that can provide locating reference, and automatically fills in the **Ref. X**, **Ref. Y**, and **Ref. Angle** fields.

 **Reference** Please refer to Section 9.1 for detailed Locate configurations.

⊙ Execute

Specifies whether to execute the inspection function in the inspection process.

▶ Always Execute

Always execute the inspection function in Run mode.

▶ Never Execute

Never execute the inspection function in Run mode.

⊙ Save

Saves all modified parameters and values.

⊙ Exit

Leaves the dialog box.

◎ **Output Item**

➤ **Window**

Selects the output window for the total Judge result for the Bar Code inspection tool on the designated interface.

➤ **Item**

- 1) **Barcode Type:** outputs the type ID (Serial No.) of the 1D bar code found. The following table lists the type IDs.

Serial No.	Barcode Type
0	No barcode
1	CODE39
2	CODE93
3	CODE128
4	I25
5	EAN8
6	UPCE
7	ISBN10
8	UPCA
9	EAN13
10	ISBN13
11	DAH CODE

- 2) **Barcode Character:** outputs the designated character contents from a string.
- 3) **Barcode Character Count:** outputs the number of characters from the bar code.
- 4) **Bar Code.ID:** outputs the ID of the inspection tool.
- 5) **String Content:** outputs the content of strings from the bar code.
- 6) **String Content (J):** determines whether the bar code content found is consistent with the configuration and outputs OK when the contents are identical.

5.15 2D Bar Code

The 2D Bar Code tool reads two-dimensional bar codes by searching for valid 2D bar codes in the ROI, decoding the bar code upon detection, and outputting the result. This tool supports QR Code and Data Matrix.

⊙ **Algorithmic Processing**

➤ 2D Bar Code Scanning Methods

The 2D Bar Code tool supports only one type of ROI: Rectangular.

Type: Auto Detect

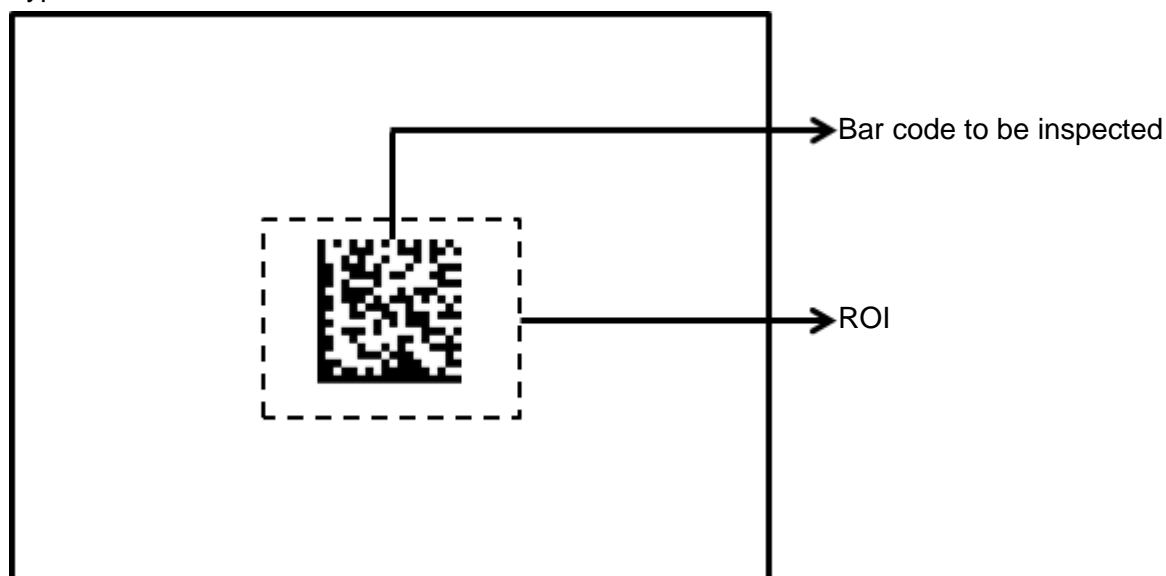

⊙ **Procedural Results**

The 2D Bar Code tool returns the following inspection results.

➤ Type: outputs the type ID (Serial No.) of the 2D bar code found. The following table lists the type IDs.

Serial No.	Barcode Type
0	No barcode
1	QR CODE
2	DATA MATRIX

◎ Example

Select the bar code to be inspected using the Rectangular ROI and the 2D Bar Code tool displays the inspection result above the bar code.

Type: Auto Detect

Inspection result: Delta Electronics

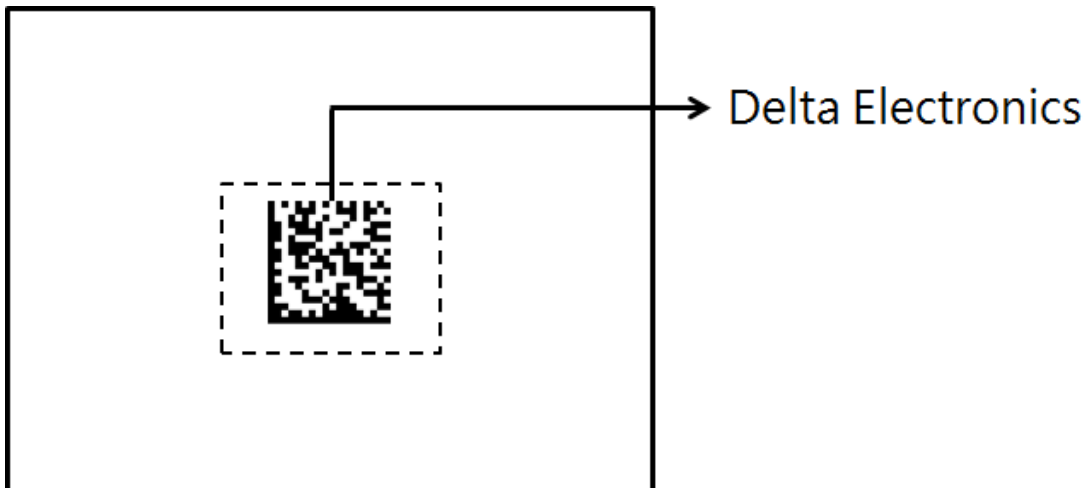

◎ 2D Bar Code dialog box

The following picture shows the 2D Bar Code inspection tool dialog box.

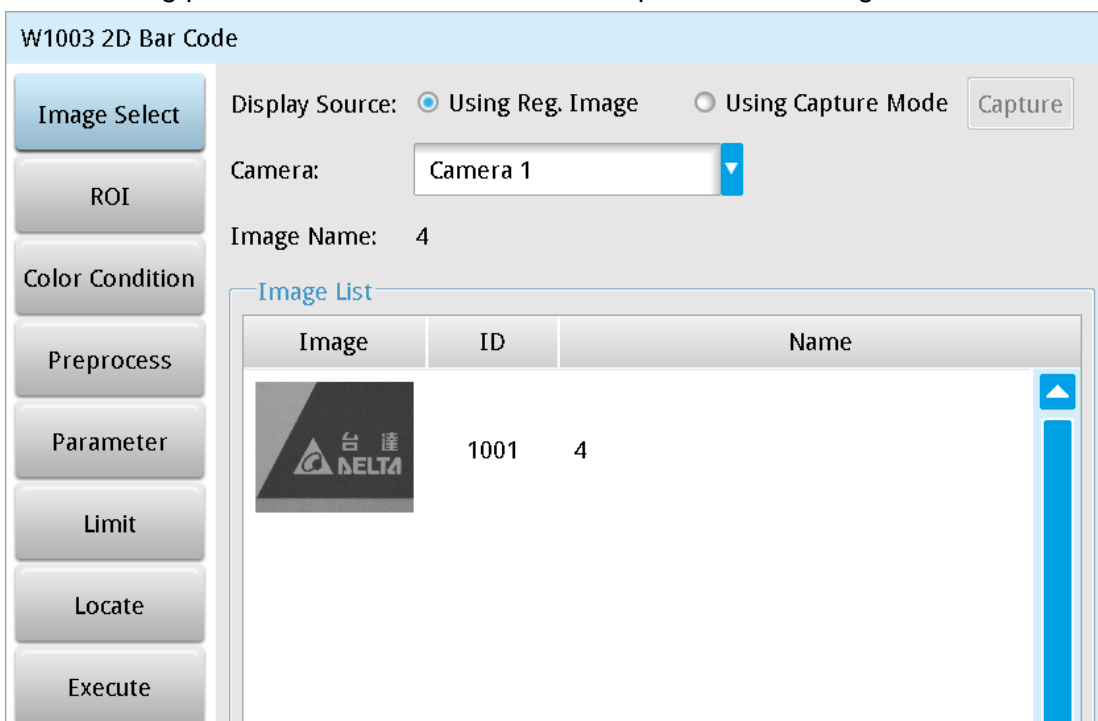

➤ Image Select (select Register Image)

Selects the image to be inspected from the register gallery. You can configure source cameras and inspect the image display source. When you select a different camera, the image table also switches to show the registered images acquired from that camera.

➤ **ROI** (configure detection region of interest)

Specifies the desired inspection regions. The only ROI available for the 2D Bar Code tool is Rectangle. Up to 8 mask functions are also provided for ignoring unwanted segments.

➤ **Color Condition**

Specifies the color processing for images from a color camera: Color to Binary, Color to Grayscale, RGB grayscale, R Grayscale, G Grayscale, and B Grayscale.

➤ **Preprocess**

Specifies the image processing to apply before inspections to enhance certain aspects of the image. Preprocessing methods include Binary, Dilation, Erosion, Average, Median, Laplacian, Sobel X, Sobel Y, Sobel XY, Brightness, Contrast, Shade, and Custom (filter). You can superimpose up to six methods or create a custom method by clicking **Custom**.

➤ **Parameters**

Adjusts the 2D Bar Code inspection tool conditions.

Type

Specifies the type of 2D Bar Code to read. Options include QR Code and Data Matrix. You can also select Auto Detect for automatic bar code type determination.

Origin

The position of the origin (0, 0) in System Setting is displayed on the upper left corner of the screen. You can enter new coordinates to move the origin to the new coordinates.

➤ **Restrictions**

After acquiring inspection results, you can view the inspection results and configure the correct bar code contents to determine whether the result qualifies.

➤ **Locate**

Specifies whether the inspection region follows an inspection result by adjusting its coordinates (X, Y) and Angles (Theta). The inspection tools you can use as a reference includes Shape, Blob, Edge Position and Edge Angle. As shown in the following diagram, specific marks (such as the cross on the object) can be used for the Locate function.

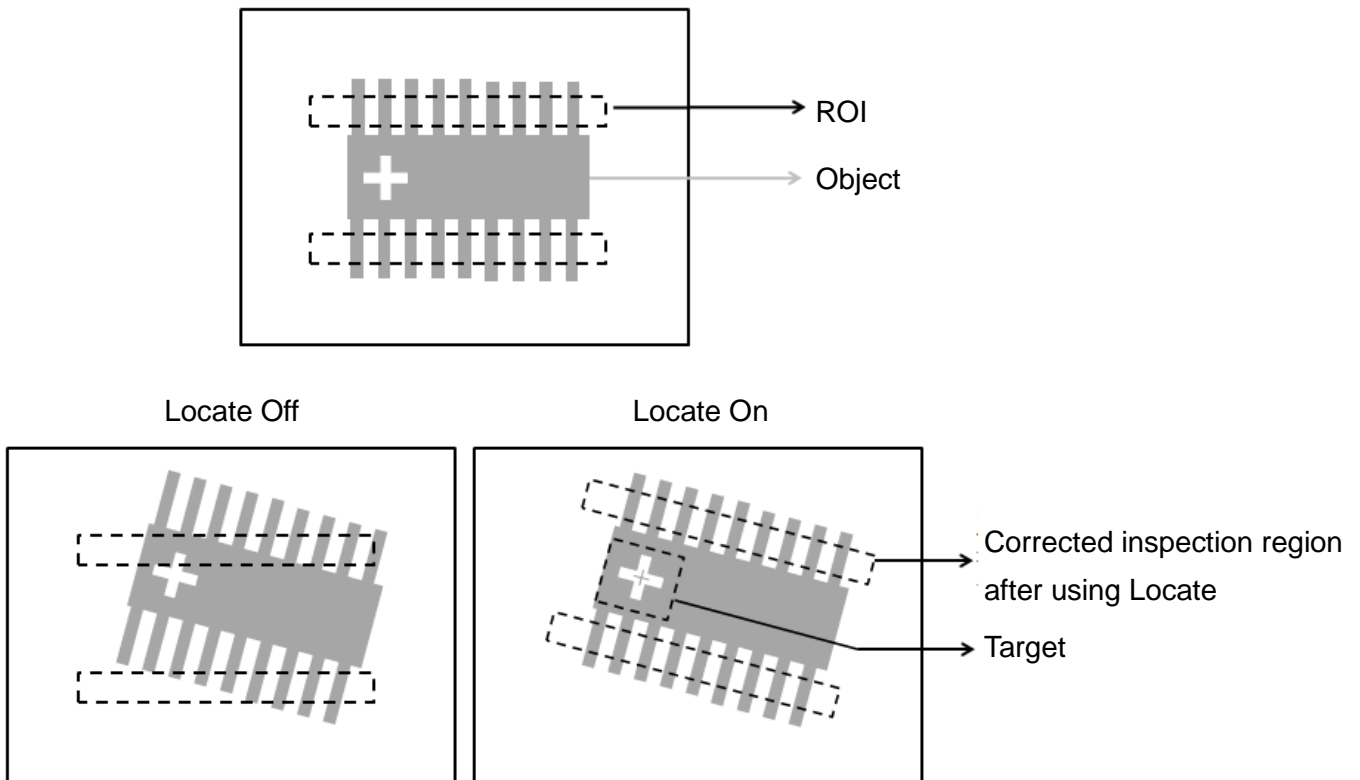

- Three tools are also provided in this item for quick configuration.

Tool

Ref. Previous Unit	Ref. Available Unit	Ref. Unit
--------------------	---------------------	-----------

Ref. X :	None	Select	CLEAR
Ref. Y :	None	Select	CLEAR
Ref. Angle :	None	Select	CLEAR

◆ Reference Previous Unit

Selects the nearest inspection tool that can provide reference for Locate, and automatically fills in the **Ref. X**, **Ref. Y**, and **Ref. Angle** fields.

◆ Reference Available Unit

Selects the nearest unit with Locate configured, and automatically fills in the **Ref. X**, **Ref. Y**, and **Ref. Angle** fields.

◆ Reference Unit

Arbitrarily selects an inspection tool that can provide locating reference, and automatically fills in the **Ref. X**, **Ref. Y**, and **Ref. Angle** fields.

 **Reference** Please refer to Section 9.1 for detailed Locate configurations.

⊙ Execute

Specifies whether to execute the inspection function in the inspection process.

➤ Always Execute

Always execute the inspection function in Run mode.

➤ Never Execute

Never execute the inspection function in Run mode.

⊙ Save

Saves all modified parameters and values.

⊙ Exit

Leaves the dialog box.

⊙ Output Item

➤ Window

Selects the output window for the total Judge result for the 2D Bar Code inspection tool on the designated interface.

➤ Item

1) **Barcode Type**: outputs the type ID (Serial No.) of the 2D bar code found. The following table lists the type IDs.

Serial No.	Barcode Type
0	No barcode
1	QR CODE
2	DATA MATRIX

2) **Barcode Character**: outputs the designated character contents from a string.

3) **Barcode Character Count**: outputs the number of characters from the barcode.

4) **2D Bar Code. ID**: outputs the ID of the inspection tool.

5) **String Content**: outputs the content of strings from the barcode.

6) **String Content (J)**: determines whether the bar code content found is consistent with the configuration and outputs OK when the contents are identical.

5.16 1P Position

The coordinate units for machine visual inspection are in pixels, and the coordinate units for devices (for example, mechanical arms) are in actual physical units (for example, mm). When machine visual inspection is coordinated with devices, the DVM2000 system creates and uses the coordinate conversion matrix (CCM) to convert between the visual and physical coordinate systems.

5.16.1 Coordinate Conversion Matrix Models

The DMV 2000 provides three CCM models.

- 1) **4 Points Learning:** First you determine and enter the pixel and mechanical coordinates of four target points in the viewing region. Then the DMV2000 converts the machine visual inspection coordinate system (pixels) to the device coordinate system (for example, mm).

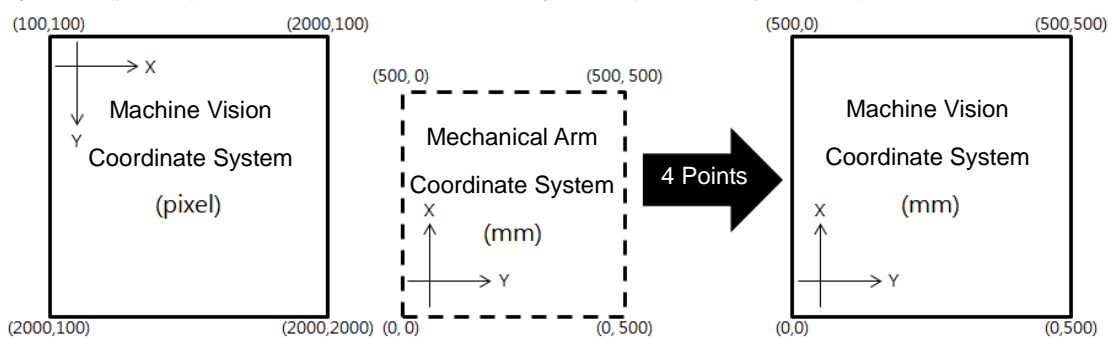

- 2) **9 Points Learning:** similar to 4 Points Learning, you move the target object using a mechanical arm or device through a total of nine points in the viewing region. The following picture shows the nine points; note that the angles are not included (the object does not rotate). The machine visual inspection system completes the conversion between pixel and mechanical coordinates. The learning path in 9 Points Learning does not include the angles; therefore, you cannot use 9 Points Learning when the object shows angular deviations; instead, use 11 points learning when there are angular deviations.

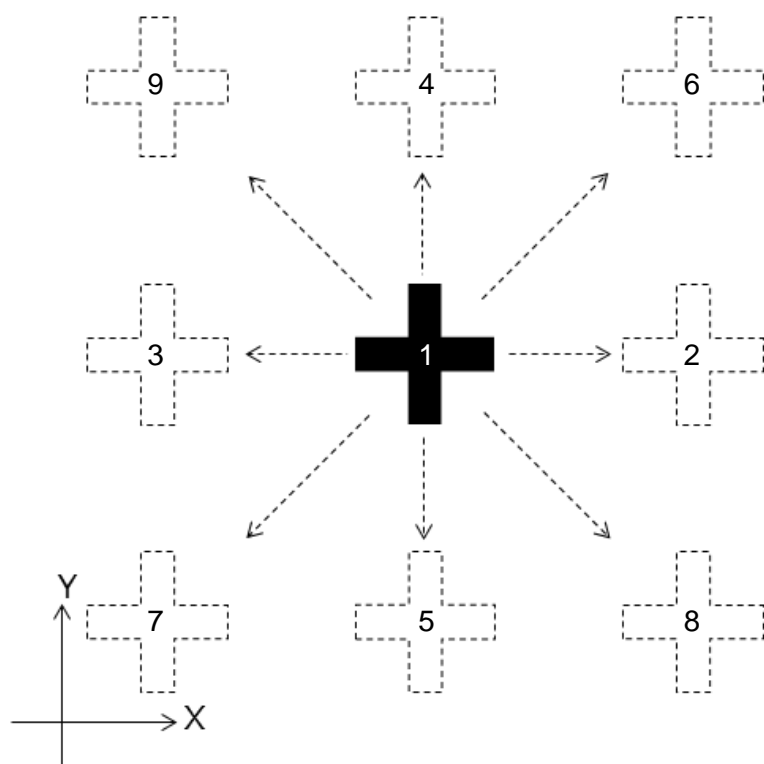

- 3) **11 Points Learning:** Similar to Nine Points Learning, you move the target object using a mechanical arm or device through a total of 11 points in the viewing region. The following picture shows the 11 points; note that the angles are included. The machine visual inspection system completes the conversion between pixel and mechanical coordinates.

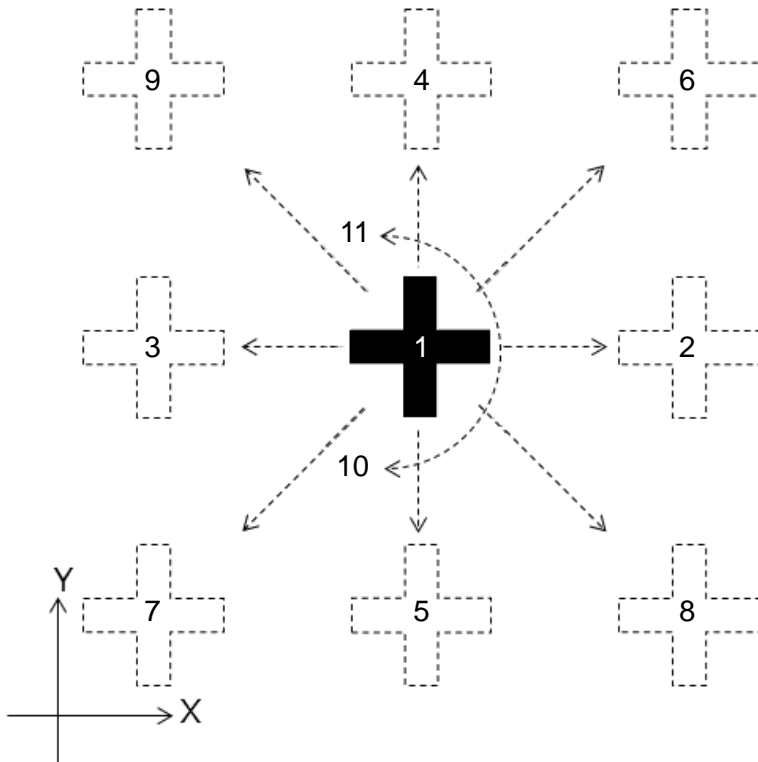

5.16.2 The Coordinate Conversion Matrix

◎ 4 Points Learning

Application: 4 Points Learning is suitable for inspecting object positions for fixed-position cameras. All four calibration points must be visible within the viewing region (as shown in the following diagram).

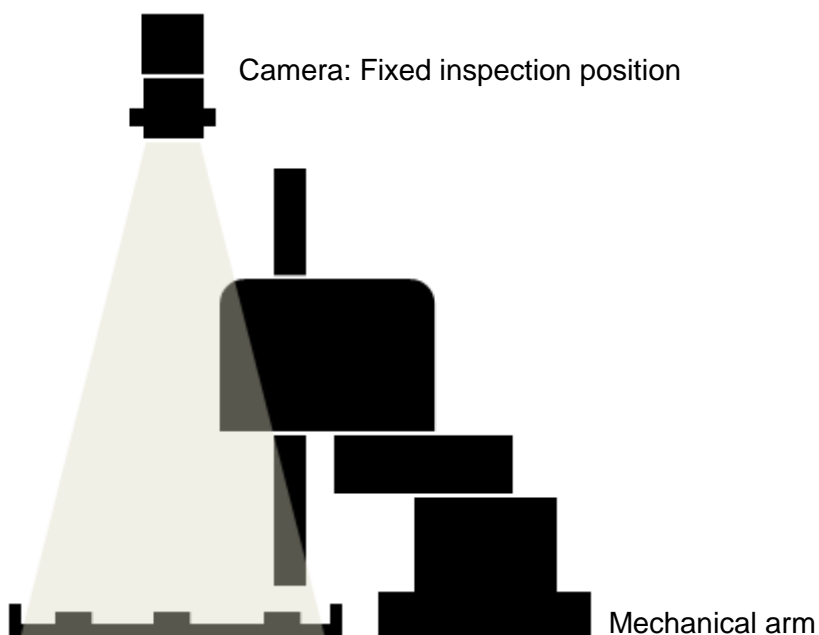

► Flow Configuration

- 1) The system confirms whether four specific points are present in the inspection region for 4 Points Learning. If the points are absent, you must first identify and mark the four specific points in the inspection region, as shown in the following diagram.

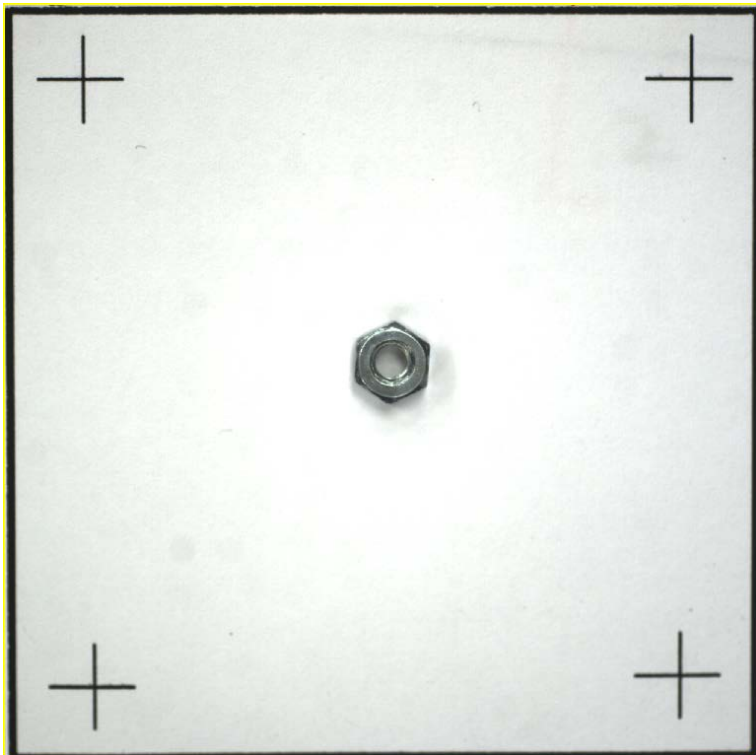

- 2) In the DMV2000 software, add a new 1P Position inspection in the flow process. See Chapter 4 for the steps to create a flow process.

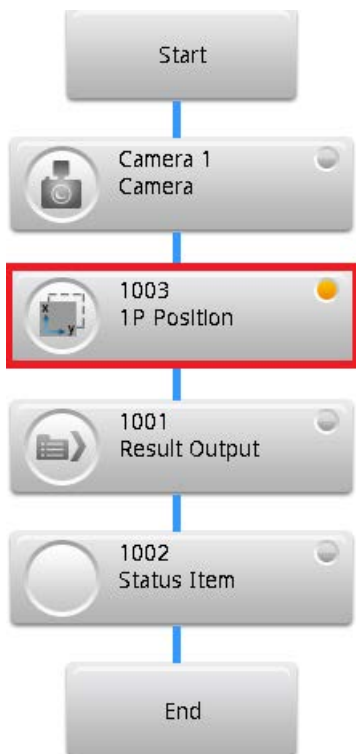

- 3) Click the icon on the left side of the 1P Position box to display the setup dialog box (shown below). Configure the camera and for the **Learning Method** select **4 Points Learning**. If the coordinate conversion matrix (CCM) is not completely configured, the button next to the Learning Method is labeled **CCM is not ready**. Click this button to configure the coordinate conversion matrix.

W1003 1P Position

Camera Setup

Camera Camera 1

Learning Method 4 Points Learning CCM is not ready

Target Search Setting

1st Point Shape Setup

- 4) In the CCM configuration **Image Points** dialog box, you must first identify the pixel coordinates. First, click **P1** and then click the first point in the screen image to get the pixel coordinates for P1. Repeat this three more times to get the pixel coordinates for the four points, as shown in the following diagram.

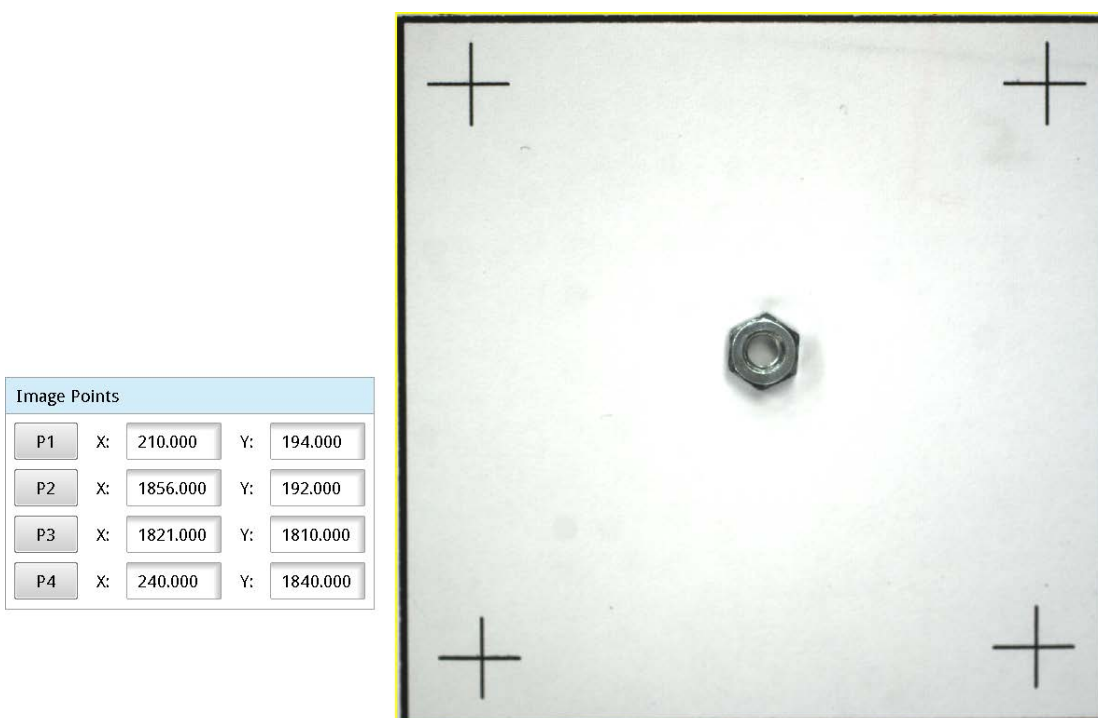

- 5) Next, in the CCM configuration, display the **Robot Arm Points** dialog box, then move the mechanical arm to points 1, 2, 3, and 4 and enter the respective mechanical arm coordinates for P1–P4, as shown in the following diagram.

Robot Arm Points			
P1	X:	<input type="text" value="0.000"/>	Y: <input type="text" value="0.000"/>
P2	X:	<input type="text" value="5.000"/>	Y: <input type="text" value="0.000"/>
P3	X:	<input type="text" value="5.000"/>	Y: <input type="text" value="5.000"/>
P4	X:	<input type="text" value="0.000"/>	Y: <input type="text" value="5.000"/>

- 6) Click **Learning** to complete the 4 Points Learning function.
- 7) Return to the **1P Position** dialog box to configure the search tool (for example, Shape) under **Target Search Setting**, and then click **Setup** to configure the tool settings.

W1003 1P Position	
Camera Setup	
Camera	<input type="text" value="Camera 1"/>
Learning Method	<input type="text" value="4 Points Learning"/> <input type="button" value="CCM is Ready."/>
Target Search Setting	
1st Point	<input type="text" value="Shape"/> <input type="button" value="Setup"/>

➤ Procedural Results

1P Position with 4 Points Learning returns the following inspection results

- 1) **1P Position X**: outputs the absolute X coordinate of the target object after applying 4 Points Learning.
- 2) **1P Position Y**: outputs the absolute Y coordinate of the target object after applying 4 Points Learning
- 3) **1P Position T**: outputs the absolute angle of the target object after applying 4 Points Learning

► Execution Result

The X, Y, and T values acquired for 1P Position with 4 Points Learning are the absolute coordinates of the target object (shown in the following diagram).

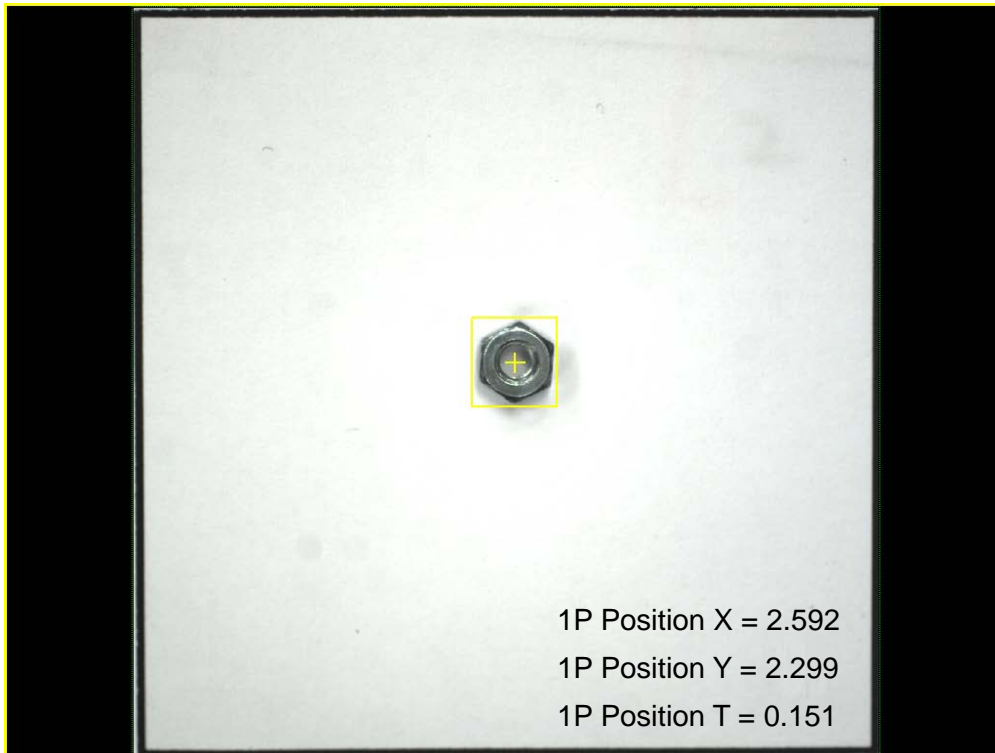

◎ 9 Points Learning

Application: 9 Points Learning is suitable for target objects that are carried using a mechanical arm, and for objects without angular deviations (as shown in the following diagram).

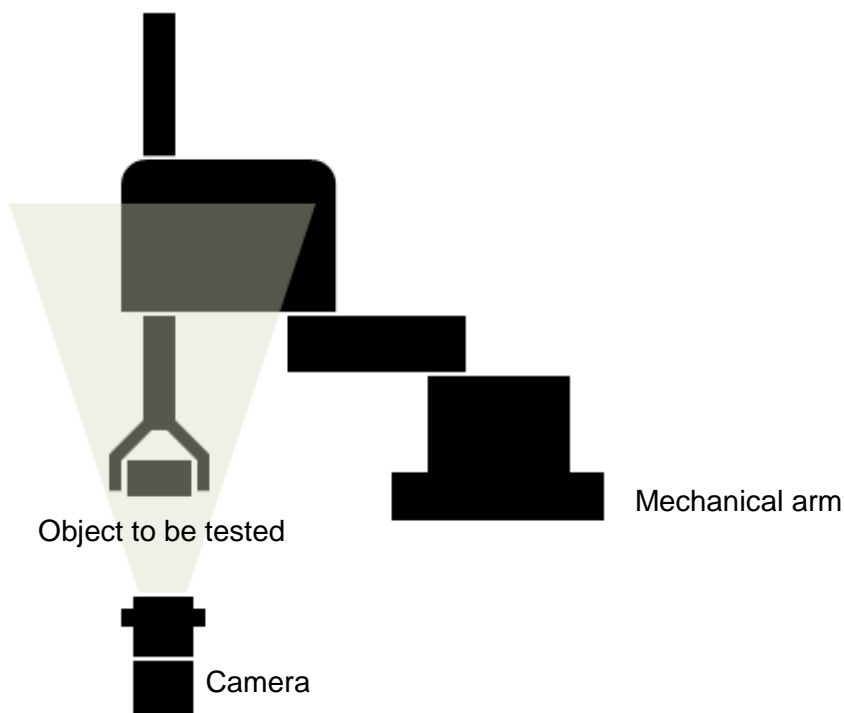

► Flow Configuration

- 1) Use the mechanical arm to move the target object into the inspection region and position the feature of the object as close to the center of the screen as possible (as shown in the following diagram). You can use this point as the first learning point, or P1.

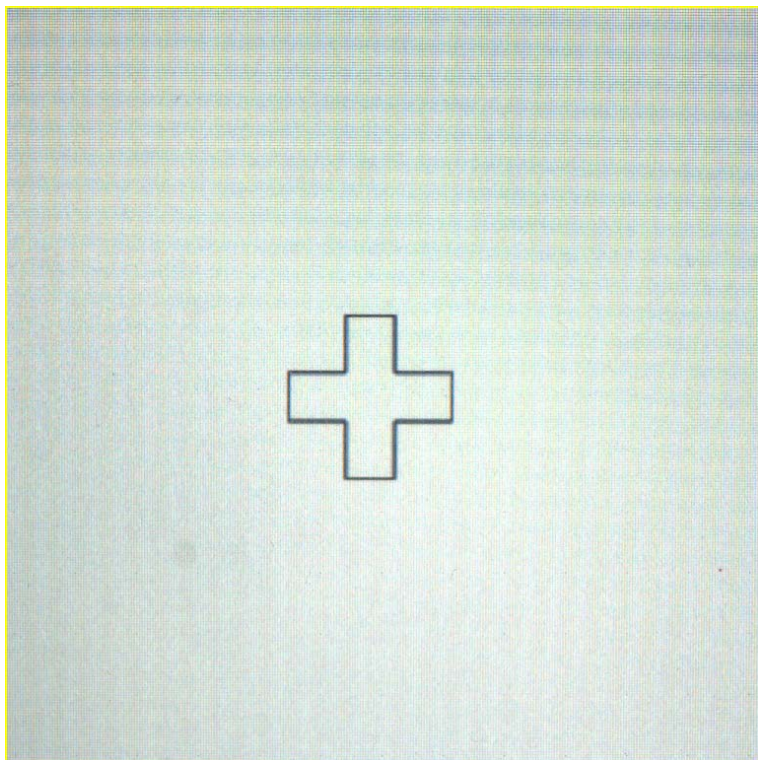

- 2) Use the mechanical arm to move the target object in the X and Y directions and confirm the maximum X and Y displacement within the DMV2000 system's inspection region. As shown in the following diagram, the maximum X and Y displacements are both 10 mm; therefore, you must limit the X and Y displacements during the learning process to within 10 mm to ensure successful learning.

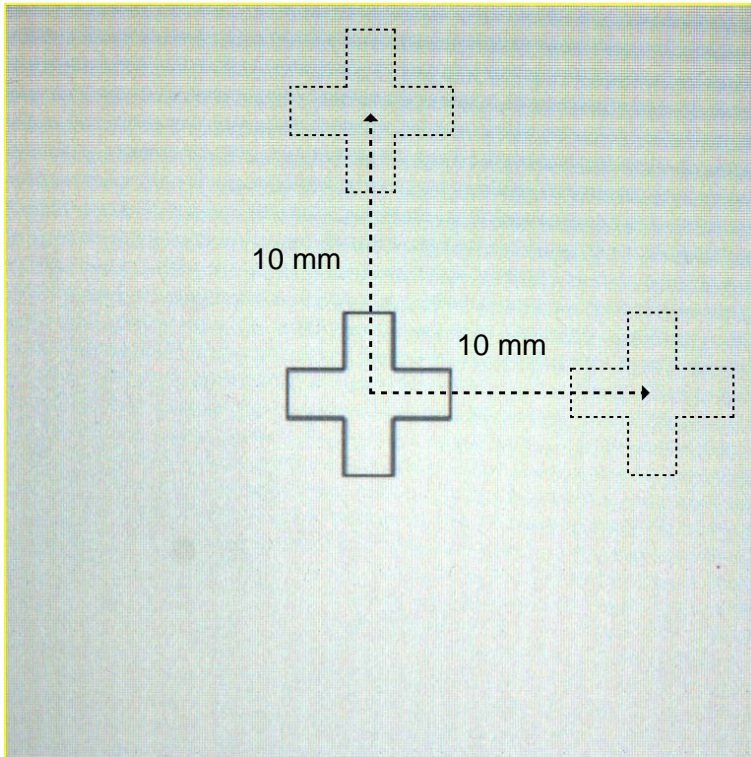

- 3) Add a new 1P Position inspection in the flow process. See Chapter 4 for the steps to create a flow process.

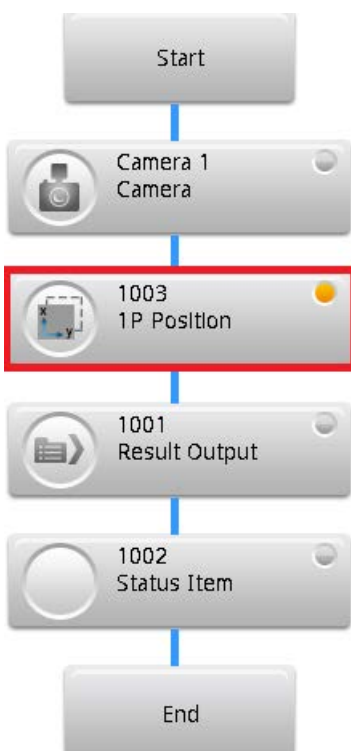

- 4) Click the icon on the left side of the **1P Position** box to display the setup dialog box. Select the **Camera** and for the **Learning Method** select **9 Points Learning**. If the CCM is not completely configured, the button next to the Learning Method is labeled **CCM is not ready**.; Click this button to configure the coordinate conversion matrix.

W1003 1P Position

Camera Setup

Camera

Learning Method

Target Search Setting

1st Point

- 5) If both the input dx and dy values are 10 mm, you can directly enter 10.000 (as shown in the following diagram); however, the learning process fails if the feature exceeds the viewing region during the learning process. After entering the displacements, select the **Target Search Setting** tool (for example, Shape), and then click **Setup** to configure the tool settings for learning.

Learning Parameter Setting

dx dy

Following Arm

Target Search Setting

1st Point

After entering the dx and dy values, follow this learning path:

P1: X, Y

P2: X + (dx), Y

P3: X - (dx), Y

P4: X, (Y + dy)

P5: X, (Y - dy)

P6: X + (dx), Y + (dy)

P7: X - (dx), Y - (dy)

P8: X + (dx), Y - (dy)

P9: X - (dx), Y + (dy)

Remember that the learning path in 9 Points Learning does not include the angles; therefore, you cannot use 9 Point Learning cannot when the object shows angular deviations. Use 11 Points Learning instead.

- 6) Click **Learning** when you complete the settings for the 1P position. The system enters the learning mode and shows a progress bar on the screen that displays the learning progress. During the learning process, move the mechanical arm to P1 with the DMV2000 triggered, then move the mechanical arm to P2 through P9 and trigger the DMV2000 at each point to completing the learning process.
- 7) Return to the 1P Position setup dialog box. Select the search tool (for example, Shape) under **Target Search Setting**, and then click **Setup** to configure the tool settings for the actual application.

➤ Procedural Results

1P Position with 9 Points Learning returns the following inspection results:

- 1) **1P Position X**: outputs the relative X coordinate (relative to P1) of the target object using mechanical arm units.
- 2) **1P Position Y**: outputs the relative Y coordinate (relative to P1) of the target object using mechanical arm units.
- 3) **1P Position T**: outputs the relative angle (relative to P1) of the target object using mechanical arm units.

➤ Execution Result

The X, Y, and T value acquired for the 1P Position with 9 Points Learning are the relative coordinates respective to the learning point P1 and are output in mechanical arm units (as shown in the following diagram).

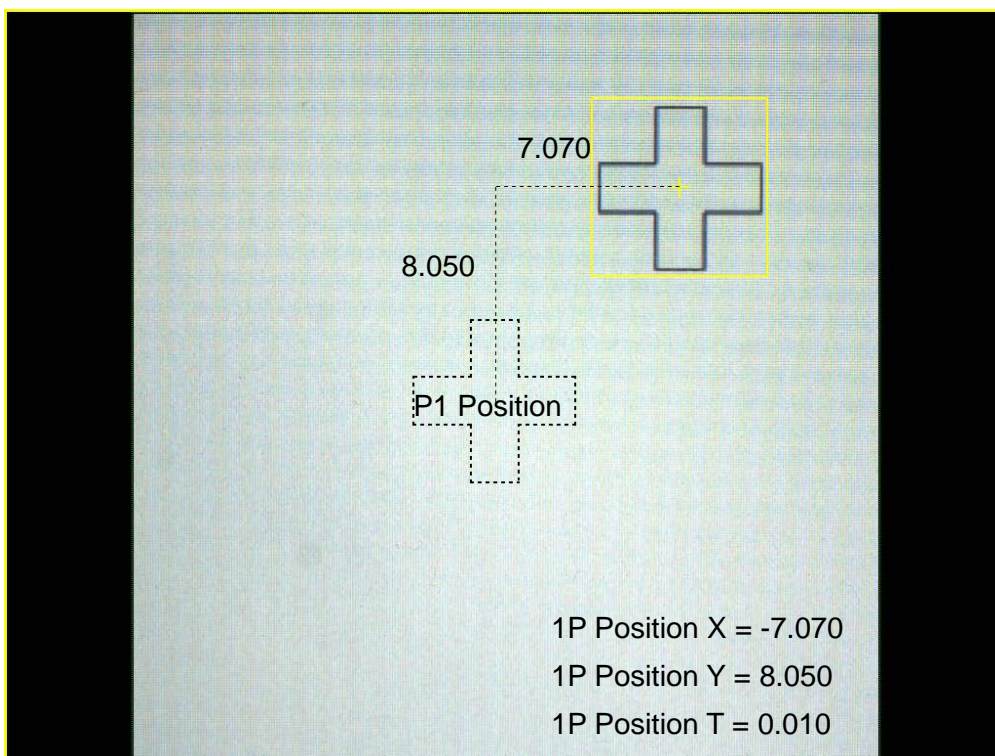

© 11 Points Learning

Application: Suitable for target objects with architectures that are carried using a mechanical arm (as shown in the following diagram).

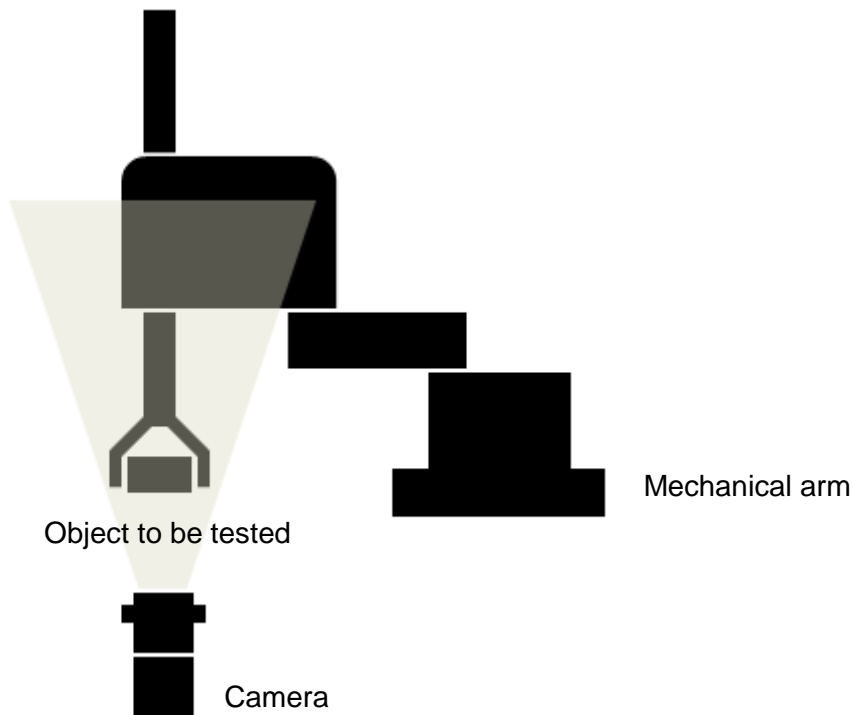

➤ Flow Configuration

- 1) Use the mechanical arm to move the target object into the inspection region and position the feature of the object as close to the center of the screen as possible (as shown in the following diagram). You can use this point as the first learning point, or P1.

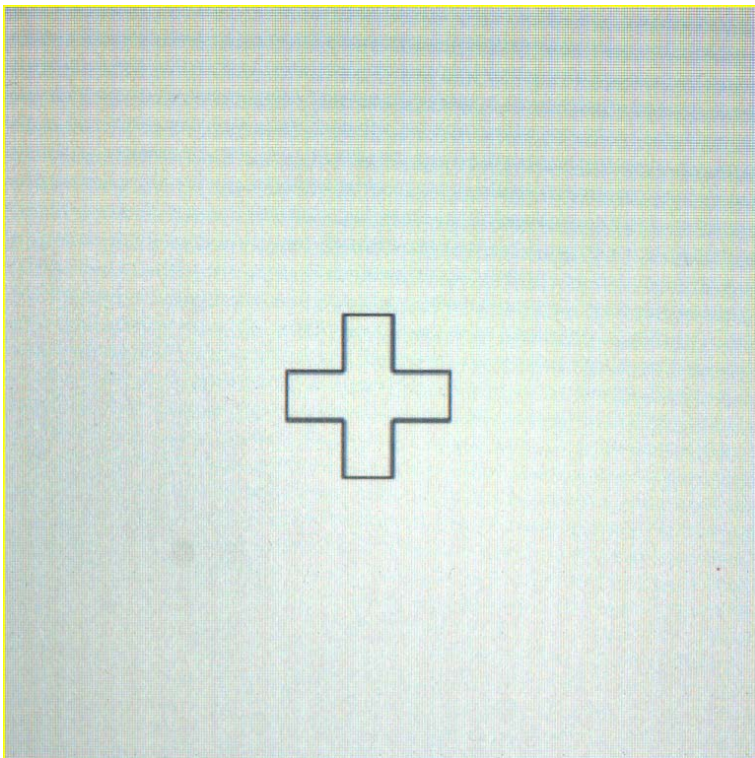

- 2) Use the mechanical arm to move the target object in the X and Y directions and confirm the maximum X and Y displacement within the DMV2000 system's inspection region. As shown in the following diagram, the maximum X and Y displacements are both 10 mm; therefore, you must limit the X and Y displacements during the learning process to within 10 mm to ensure successful learning.

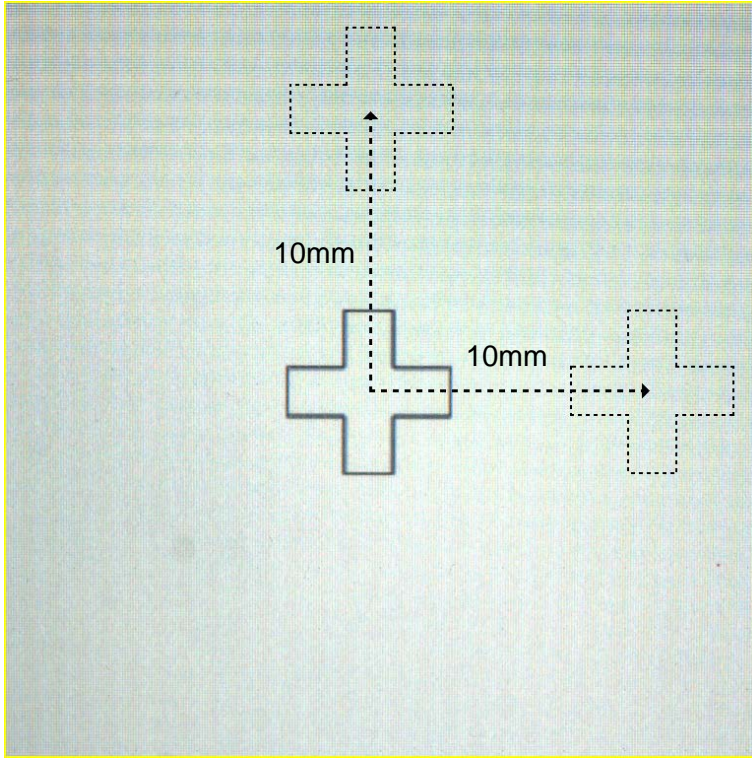

- 3) Return the mechanical arm to position P1. Rotate and move the target object using the mechanical arm, and confirm the reasonable rotation angle within the DMV2000 system's inspection region (as shown in the following diagram, the rotation angle is 10 degrees).

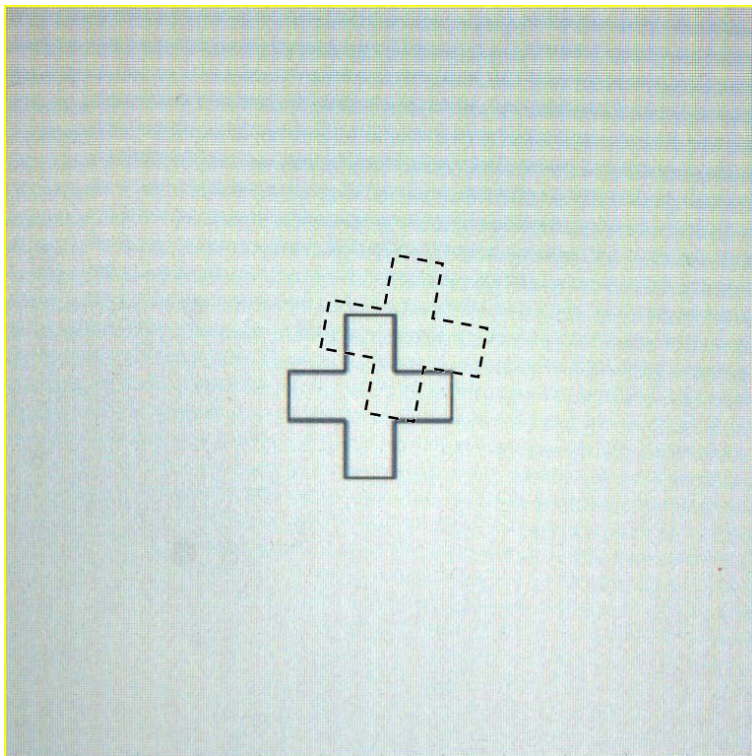

- 4) Add a new 1P Position inspection in the flow process. See Chapter 4 for the steps to create a flow process.

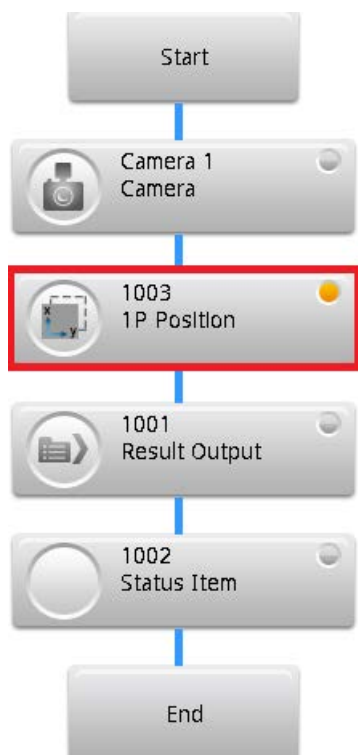

- 5) Click the icon on the left side of the 1P Position box to display the setup dialog box. Select the **Camera** and for the **Learning Method** select **11 Points Learning**. If the CCM is not completely configured, the button next to Learning Method is labeled **CCM is not ready**. Click this button to configure the coordinate conversion matrix.

W1003 1P Position	
Camera Setup	
Camera	Camera 1
Learning Method	11 Points Learning
	CCM is not ready
Target Search Setting	
1st Point	Shape
	Setup

- 6) The input parameters are dt, dx, and dy and dt represents the angle of rotation. If the angle of rotation is 10 degrees, you can directly enter 10.000. If both input dx and dy are 10 mm, you can directly enter 10.000 (as shown in the following diagram); however, the learning process fails if the feature exceeds the viewing region during the learning process. After entering the displacements, select the **Target Search Setting** tool (for example, Shape). Click **Setup** to configure the tool settings for learning.

Learning Parameter Setting			
dt	<input type="text" value="10.000"/>	dx	<input type="text" value="10.000"/>
dy	<input type="text" value="10.000"/>	Following Arm	<input type="text" value="No"/>

Target Search Setting	
1st Point	<input type="text" value="Shape"/> <input type="button" value="Setup"/>

After configuring dx and dy, follow this learning path:

P1: X, Y

P2: X + (dx), Y

P3: X - (dx), Y

P4: X, (Y + dy)

P5: X, (Y - dy)

P6: X + (dx), Y + (dy)

P7: X - (dx), Y - (dy)

P8: X + (dx), Y - (dy)

P9: X - (dx), Y + (dy)

P10: X, Y, T + (dt)

P11: X, Y, T - (dt)

The learning path in 9 Points Learning does not cover the angles. Therefore, 9 Point Learning cannot be used when the object shows angular deviations, and you should use 11 points learning for angular deviations.

- 7) Click **Learning** when you complete the settings for the 1P Position. The system enters the learning mode and shows a progress bar on the screen that displays the learning progress. During the learning process, move the mechanical arm to P1 with the DMV2000 triggered, and then move the mechanical arm to P2 through P9 and trigger the DMV2000 at each point to completing the learning process.
- 8) Return to the 1P Position setup dialog box. Select the search tool (for example, Shape) under **Target Search Setting**, and then click **Setup** to configure the tool settings for the actual application.

► Procedural Results

1P Position with 11 Points Learning returns the following inspection results:

- 1) **1P Position X**: outputs the relative X coordinate (relative to P1) of the target object using mechanical arm units.
- 2) **1P Position Y**: outputs the relative Y coordinate (relative to P1) of the target object using mechanical arm units.
- 3) **1P Position T**: outputs the relative angle (relative to P1) of the target object using mechanical arm units.

► Execution Result

The X, Y, and T values acquired for the 1P Position with 11 Points Learning are the relative coordinates respective to the learning point P1 and are output in mechanical arm units (as shown in the following diagram).

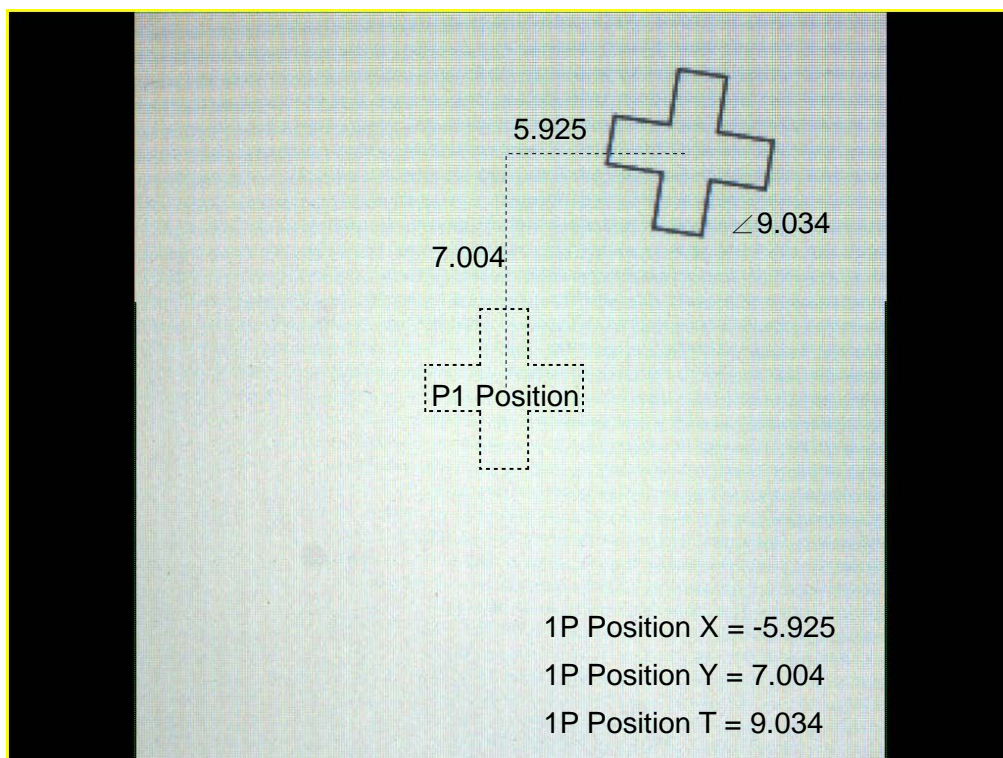

5.17 1P Location

The coordinate units for machine visual inspection are in pixels, and the coordinate units for devices (for example, mechanical arms) are in actual physical units (for example, mm). When machine visual inspection is coordinated with devices, the DMV2000 system creates and uses the coordinate conversion matrix (CCM) to convert between the visual and physical coordinate systems.

5.17.1 Coordinate Conversion Matrix Models

The DMV2000 provides three CCM models.

- 1) **4 Points Learning:** First you determine and enter the pixel and mechanical coordinates of four target points in the viewing region. Then the DMV2000 converts the machine visual inspection coordinate system (pixels) to the device coordinate system (for example, mm).

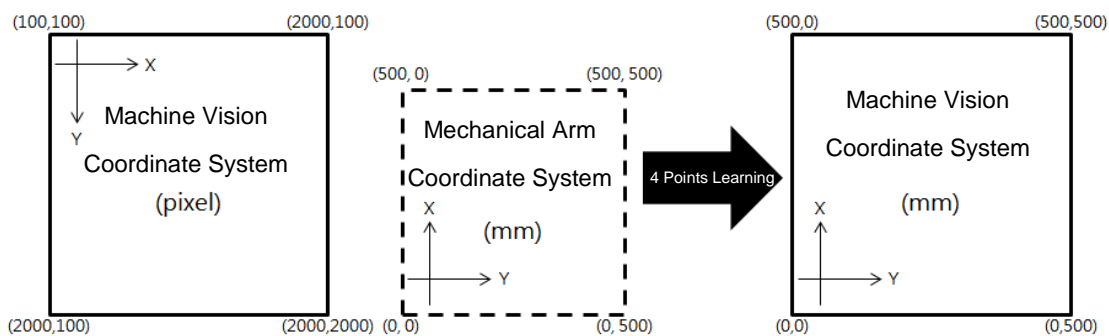

- 2) **9 Points Learning:** similar to 4 Points Learning, you move the target object using a mechanical arm or device through a total of nine points in the viewing region. The following picture shows the nine points; note that the angles are not included (the target does not rotate). The machine visual inspection system completes the conversion between pixel and mechanical coordinates. The learning path in 9 Points Learning does not include the angles; therefore, you cannot use 9 Points Learning when the object shows angular deviations. Instead, use 11 Points Learning when there are angular deviations..

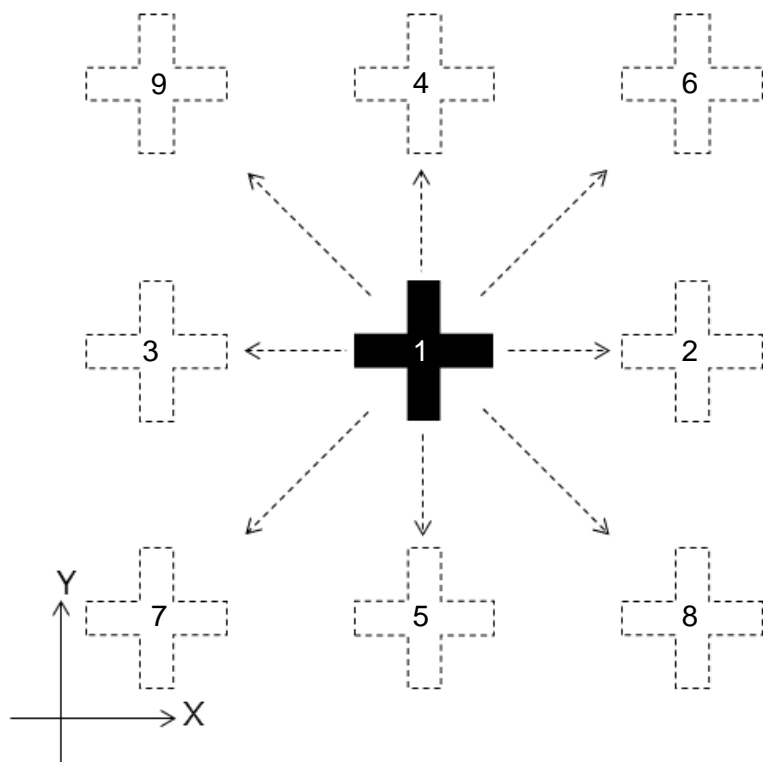

- 3) **11 Points Learning:** Similar to Nine Points Learning, you move the target object using a mechanical arm or device through a total of 11 points in the viewing region. The following picture shows the 11 points; note that the angles are included. The machine visual inspection system completes the conversion between pixel and mechanical coordinates.

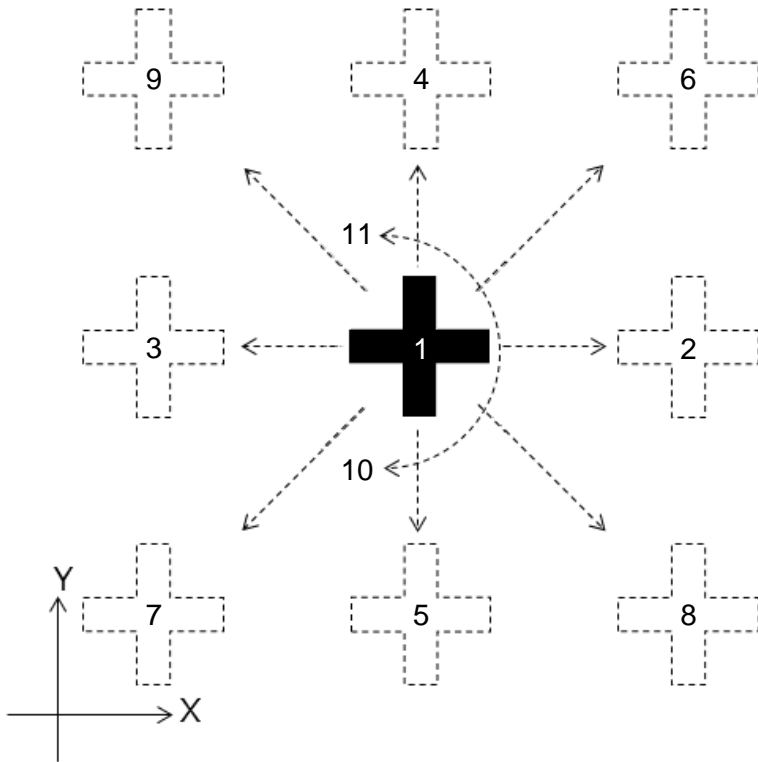

5.17.2 The Coordinate Conversion Matrix

© 4 Points Learning

Application: 4 Points Learning is suitable for inspecting object positions for fixed-position cameras. All four calibration points must be visible within the viewing region (as shown in the following diagram).

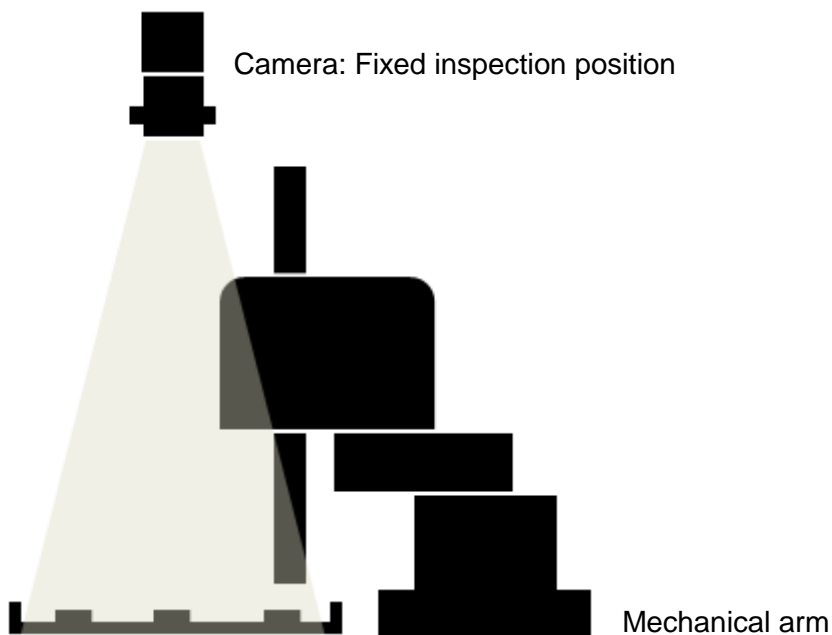

► Flow Configuration

- 1) The system confirms whether four specific points are present in the inspection region for 4 Points Learning. If the points are absent, you must first identify and mark the four specific points in the inspection region, as shown in the following diagram.

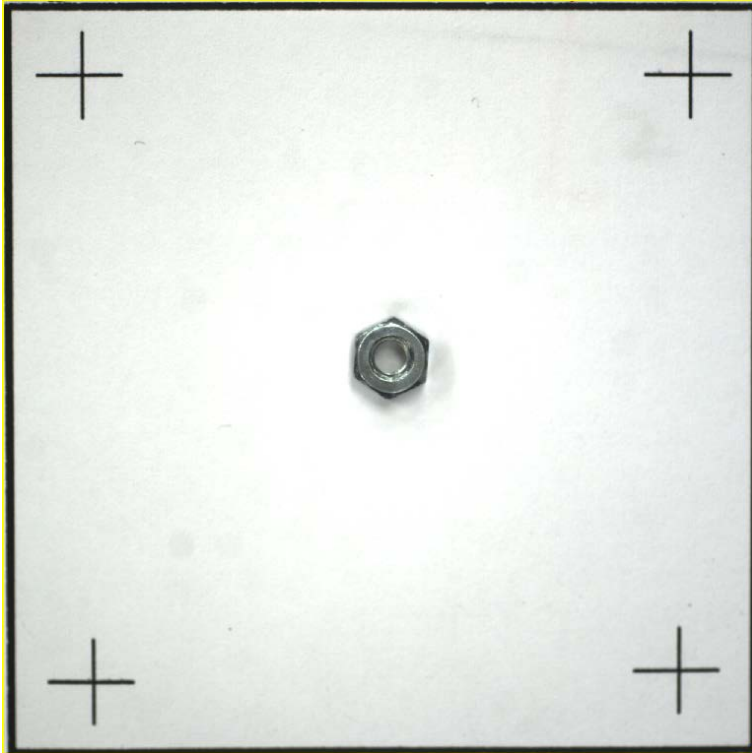

- 2) In the DMV2000 software, add a new 1P Location inspection in the flow process. See Chapter 4 for the steps to create a flow process.

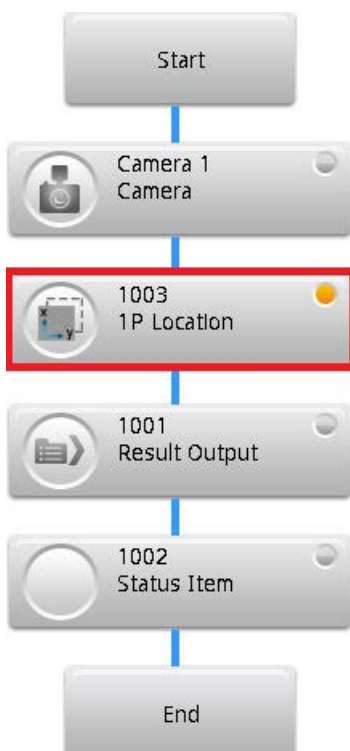

- 3) Click the icon on the left side of the 1P Location box to display the setup dialog box (shown below). Configure the camera and for the **Learning Method** select **4 Points Learning**. If the coordinate conversion matrix (CCM) is not completely configured, the button next to the Learning Method is labeled **CCM is not ready**. Click this button to configure the coordinate conversion matrix.

W1003 1P Location

Camera Setup

Camera Camera 1

Learning Method 4 Points Learning CCM is not ready

Target Search Setting

1st Point Shape Setup

- 4) In the CCM configuration **Image Points** dialog box, you must first identify the pixel coordinates. First, click **P1** and then click the first point in the screen image to get the pixel coordinates for P1. Repeat this three more times to get the pixel coordinates for the four points, as shown in the following diagram.

Image Points			
P1	X:	<input type="text" value="210.000"/>	Y: <input type="text" value="194.000"/>
P2	X:	<input type="text" value="1856.000"/>	Y: <input type="text" value="192.000"/>
P3	X:	<input type="text" value="1821.000"/>	Y: <input type="text" value="1810.000"/>
P4	X:	<input type="text" value="240.000"/>	Y: <input type="text" value="1840.000"/>

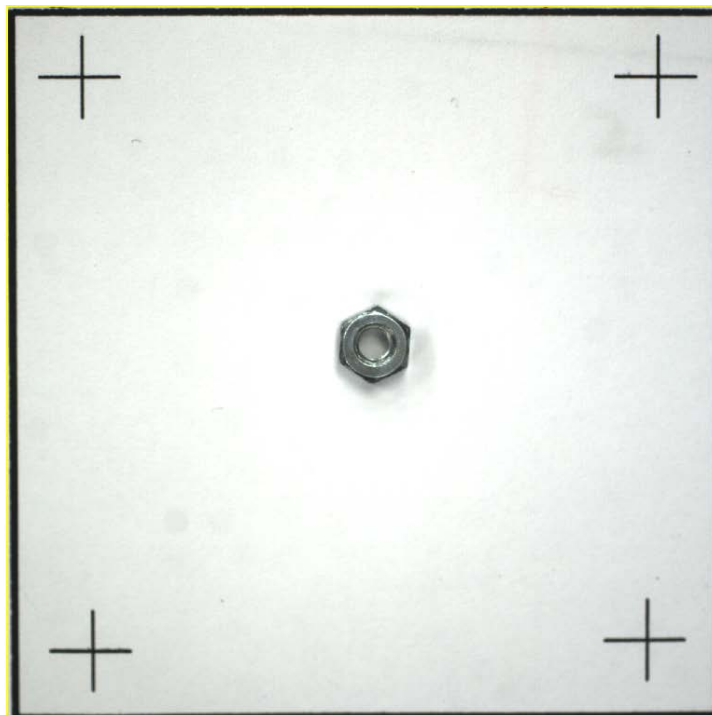

- 5) Next, in the CCM configuration, display the **Robot Arm Points** dialog box, then move the mechanical arm to points 1, 2, 3, and 4 and fill in the respective mechanical arm coordinates for P1–P4, as shown in the following diagram.

Robot Arm Points			
P1	X:	<input type="text" value="0.000"/>	Y: <input type="text" value="0.000"/>
P2	X:	<input type="text" value="5.000"/>	Y: <input type="text" value="0.000"/>
P3	X:	<input type="text" value="5.000"/>	Y: <input type="text" value="5.000"/>
P4	X:	<input type="text" value="0.000"/>	Y: <input type="text" value="5.000"/>

- 6) Click **Learning** to complete the 4 Points Learning function.
- 7) Return to the **1P Location** dialog box to configure the search tool (for example, Shape) under **Target Search Setting**, and then click **Setup** to configure the tool settings.

W1003 1P Location	
Camera Setup	
Camera	<input type="text" value="Camera 1"/>
Learning Method	<input type="text" value="4 Points Learning"/> <input type="button" value="CCM is Ready."/>
Target Search Setting	
1st Point	<input type="text" value="Shape"/> <input type="button" value="Setup"/>

► Procedural Results

1P Location with 4 Points Learning returns the following inspection results

- 1) **1P Location X**: outputs the relative X coordinate (relative to register image) of the target object after applying 4 Points Learning.
- 2) **1P Location Y**: outputs the relative Y coordinate (relative to register image) of the target object after applying 4 Points Learning
- 3) **1P Location T**: outputs the relative angle of the target object after applying 4 Points Learning

► Execution Result

The X, Y, and T values acquired for 1P Location with 4 Points Learning are the absolute coordinates of the target object (shown in the following diagram).

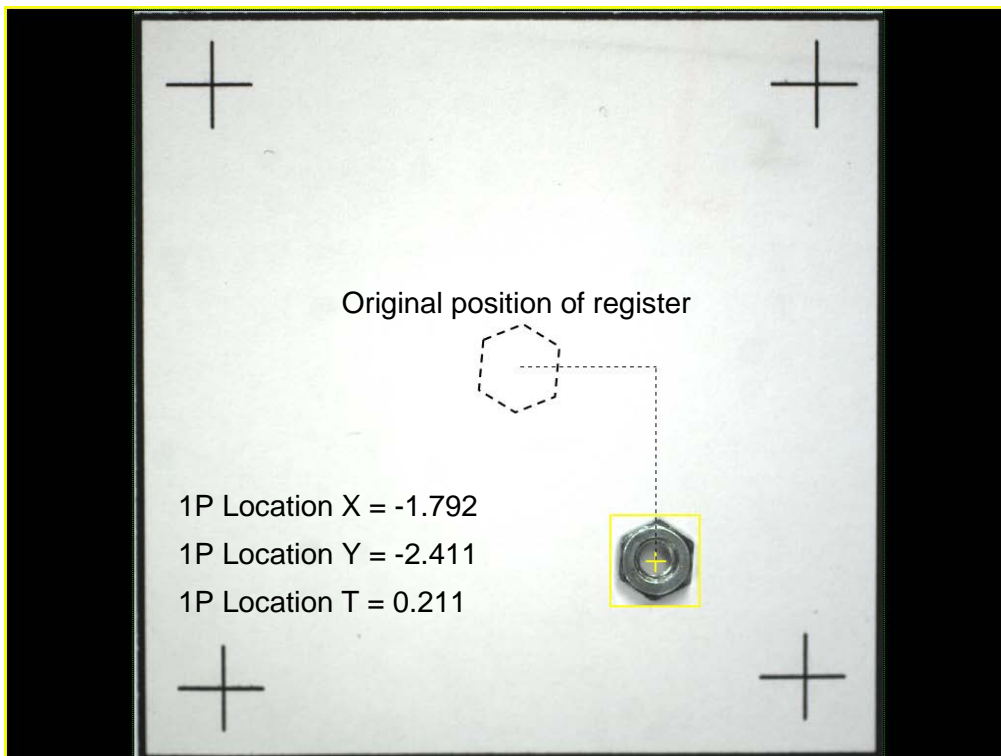

◎ 9 Points Learning

Application: 9 Points Learning is suitable for target objects that are carried using a mechanical arm, and for objects without angular deviations (as shown in the following diagram).

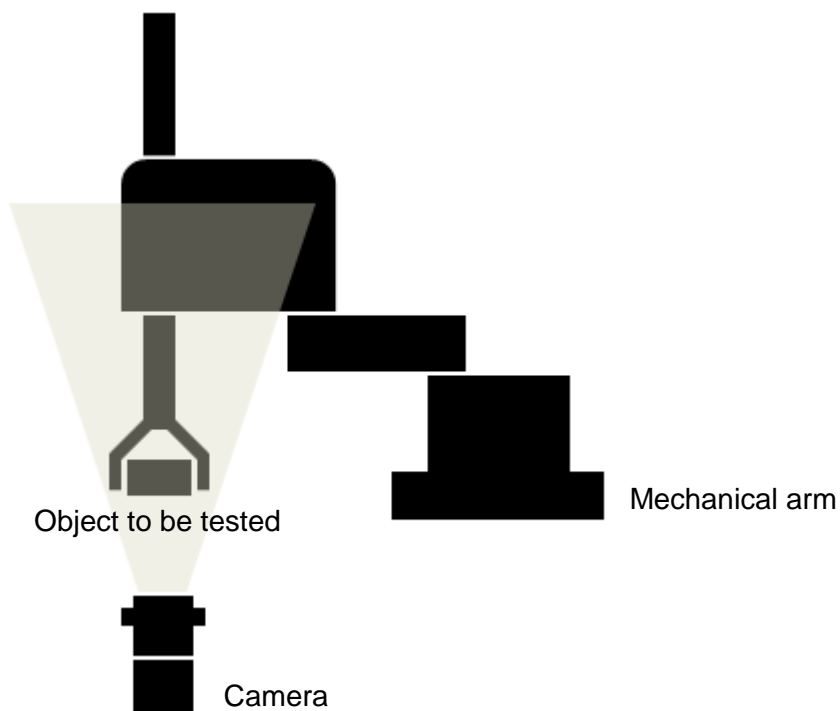

► Flow Configuration

- 1) Use the mechanical arm to move the target object into the inspection region and position the feature of the object as close to the center of the screen as possible (as shown in the following diagram). You can use this point as the first learning point, or P1.

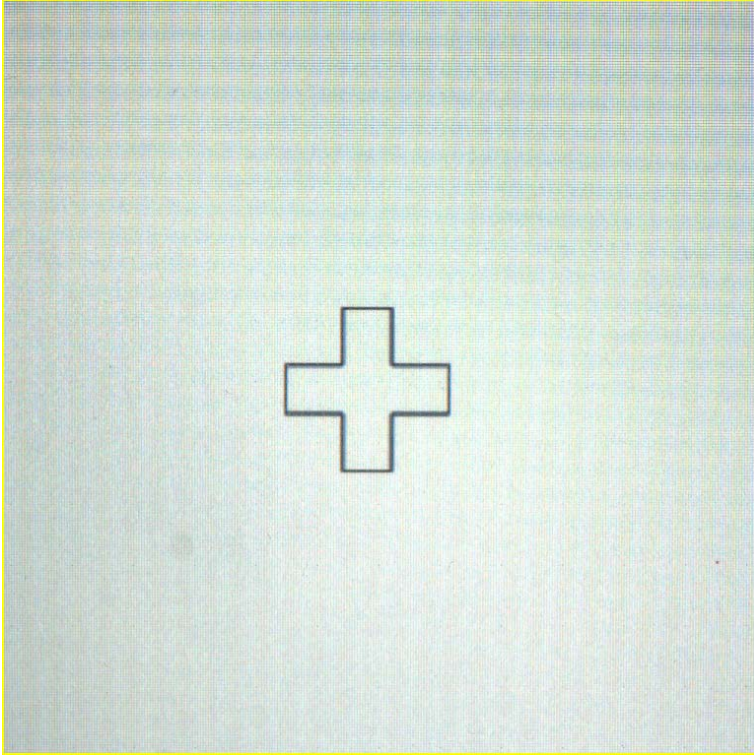

- 2) Use the mechanical arm to move the target object in the X and Y directions and confirm the maximum X and Y displacement within the DMV2000 system's inspection region. As shown in the following diagram, the maximum X and Y displacements are both 10 mm; therefore, you must limit the X and Y displacements during the learning process to within 10 mm to ensure successful learning.

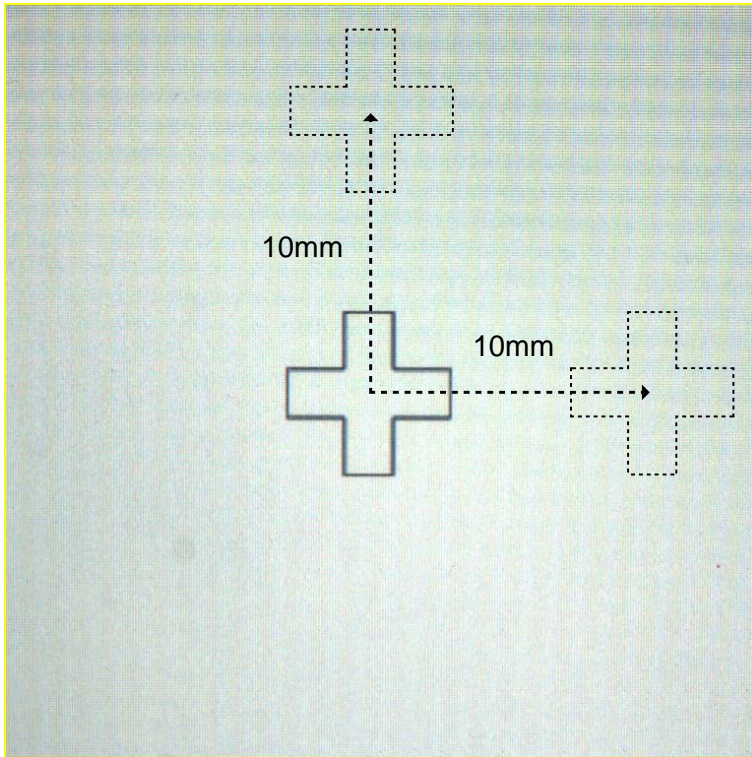

- 3) Add a new 1P Location inspection in the flow process. See Chapter 4 for the steps to create a flow process.

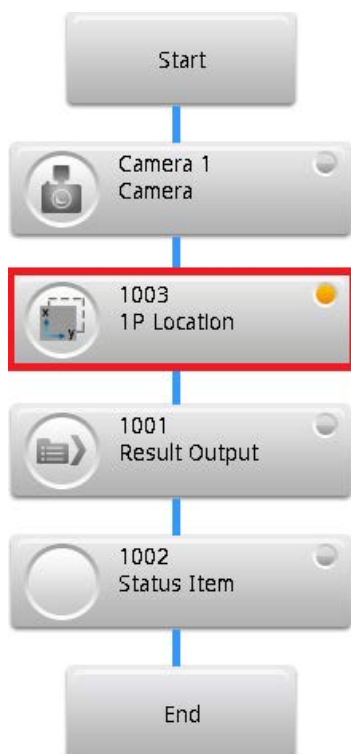

- 4) Click the icon on the left side of the **1P Location** box to display the setup dialog box. Select the **Camera** and for the **Learning Method** select **9 Points Learning**. If the CCM is not completely configured, the button next to the Learning Method is labeled **CCM is not ready**. Click this button to configure the coordinate conversion matrix.

W1003 1P Location

Camera Setup

Camera

Learning Method

Target Search Setting

1st Point

- 5) If both the input dx and dy values are 10 mm, you can directly enter 10.000 (as shown in the following diagram); however, the learning process fails if the feature exceeds the viewing region during the learning process. After entering the displacements, select the **Target Search Setting** tool (for example, Shape), and then click **Setup** to configure the tool settings.

Learning Parameter Setting

dx dy

Following Arm

Target Search Setting

1st Point

After entering the dx and dy values, follow this learning path:

- P1: X, Y
- P2: X + (dx), Y
- P3: X - (dx), Y
- P4: X, (Y + dy)
- P5: X, (Y - dy)
- P6: X + (dx), Y + (dy)
- P7: X - (dx), Y - (dy)
- P8: X + (dx), Y - (dy)
- P9: X - (dx), Y + (dy)

Remember that the learning path in 9 Points Learning does not include the angles; therefore, you cannot use 9 Point Learning cannot when the object shows angular deviations. Instead, use 11 Points Learning.

- 6) Click **Learning** when you complete the settings for the 1P Location. The system enters the learning mode and shows a progress bar on the screen that displays the learning progress. During the learning process, move the mechanical arm to P1 with DMV2000 triggered, then move the mechanical arm to P2 through P9 and trigger DMV2000 at each point to completing the learning process.
- 7) Return to the 1P Location setup dialog box. Select the search tool (for example, Shape) under **Target Search Setting**, and then click **Setup** to configure the tool settings.

➤ Procedural Results

1P Location with 9 Points Learning returns the following inspection results:

- 1) **1P Location X**: outputs the relative X coordinate (relative to register image) of the target object using mechanical arm units.
- 2) **1P Location Y**: outputs the relative Y coordinate (relative to register image) of the target object using mechanical arm units.
- 3) **1P Location T**: outputs the relative angle (relative to register image) of the target object using mechanical arm units.

➤ Execution Result

The X, Y, and T value acquired for the 1P Location with 9 Points Learning are the relative coordinates of the target object respective to the register image and are output in mechanical arm units (as shown in the following diagram).

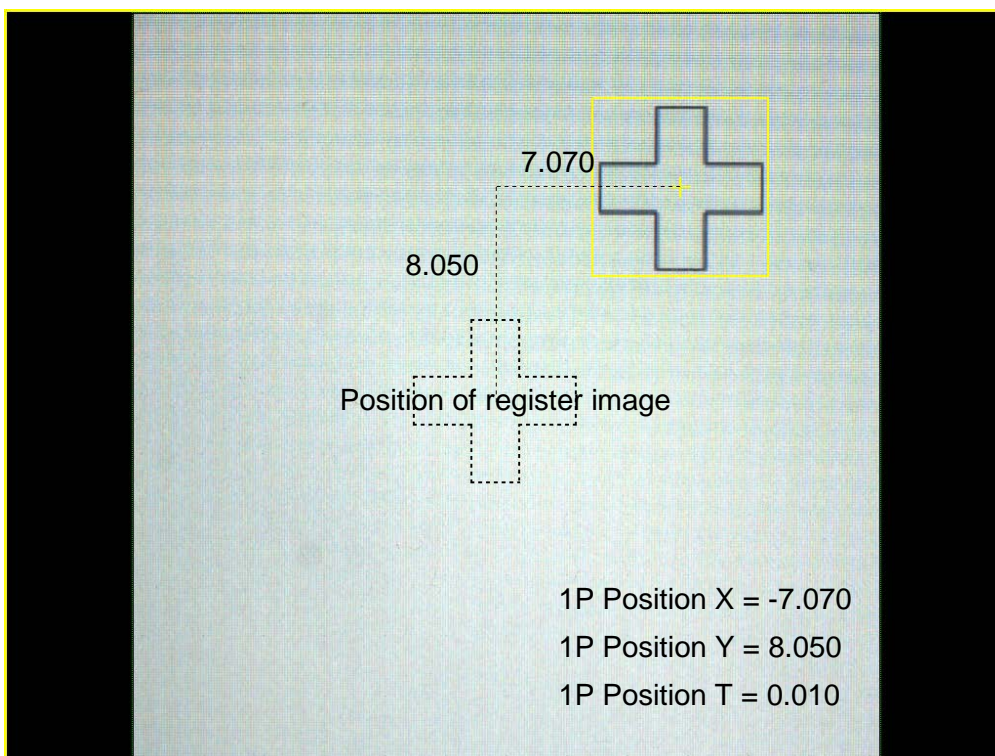

© 11 Points Learning

Application: Suitable for target objects with architectures that are carried using a mechanical arm (as shown in the following diagram).

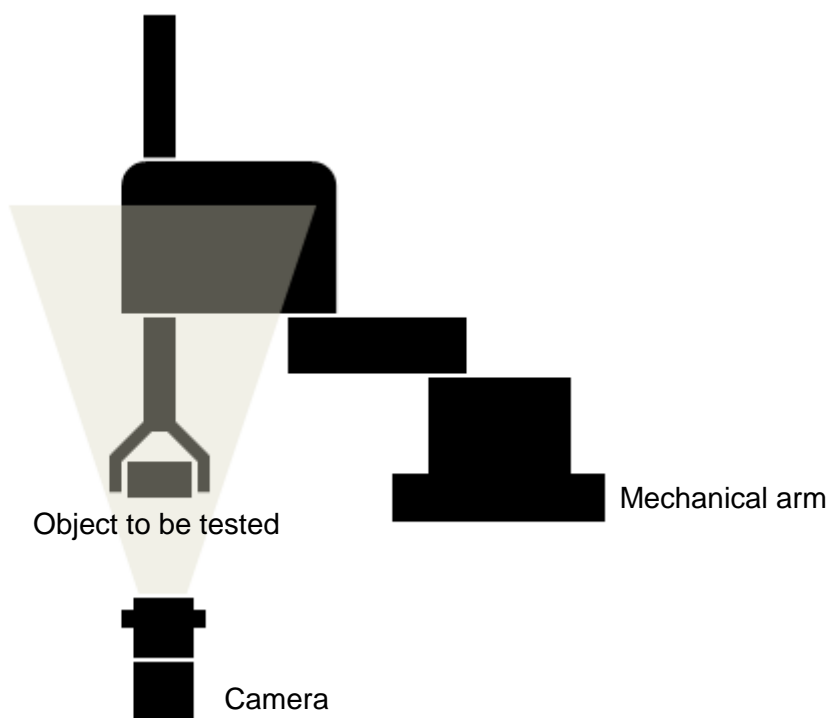

➤ Flow Configuration

- 1) Use the mechanical arm to move the target object into the inspection region and position the feature of the object as close to the center of the screen as possible (as shown in the following diagram). You can use this point as the first learning point, or P1.

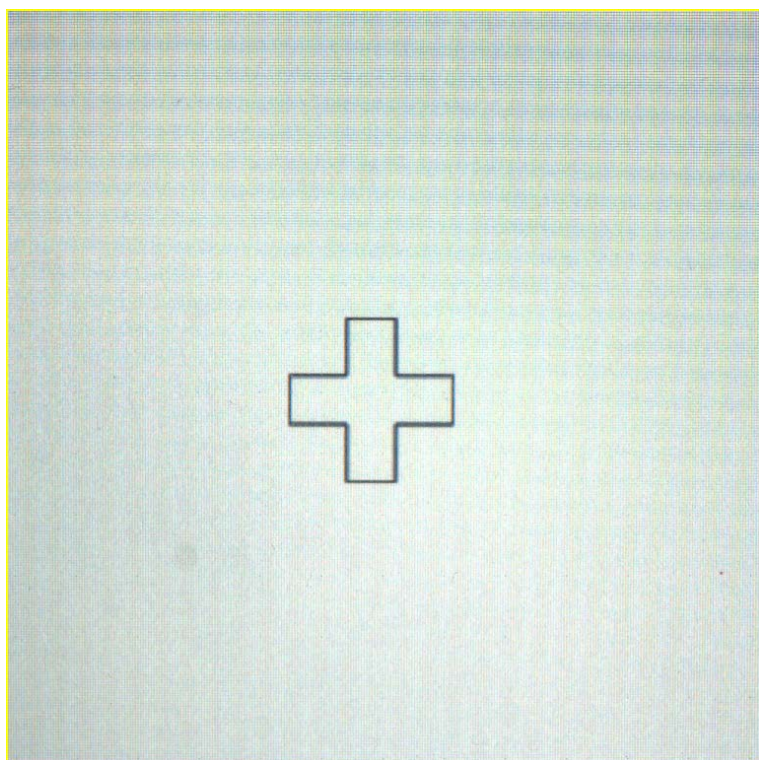

- 2) Use the mechanical arm to move the target object in the X and Y directions and confirm the maximum X and Y displacement within the DMV2000 system's inspection region. As shown in the following diagram, the maximum X and Y displacements are both 10 mm; therefore, you must limit the X and Y displacements during the learning process to within 10 mm to ensure successful learning.

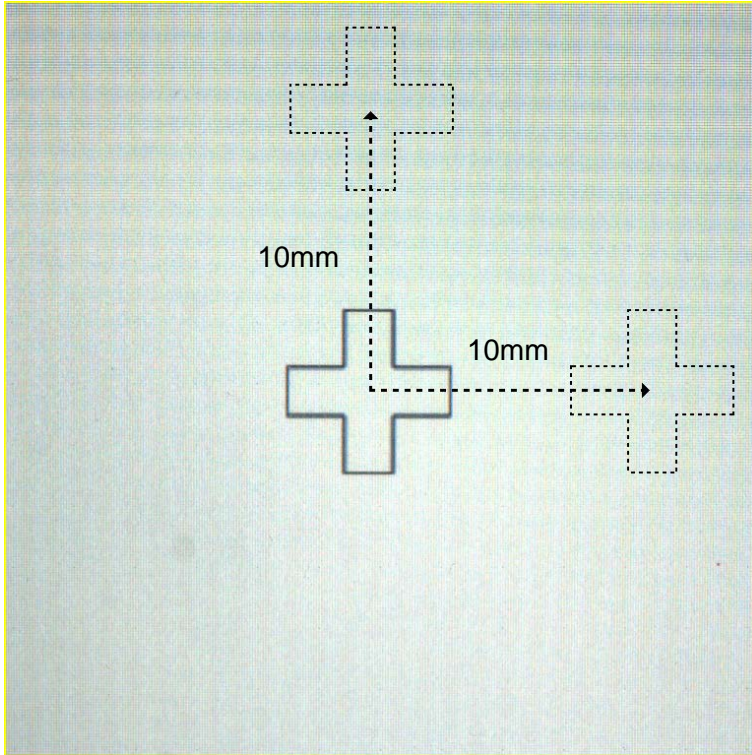

- 3) Return the mechanical arm to position P1. Rotate and move the target object using the mechanical arm, and confirm the reasonable rotation angle within the DMV2000 system's inspection region (as shown in the following diagram, the rotation angle is 10 degrees).

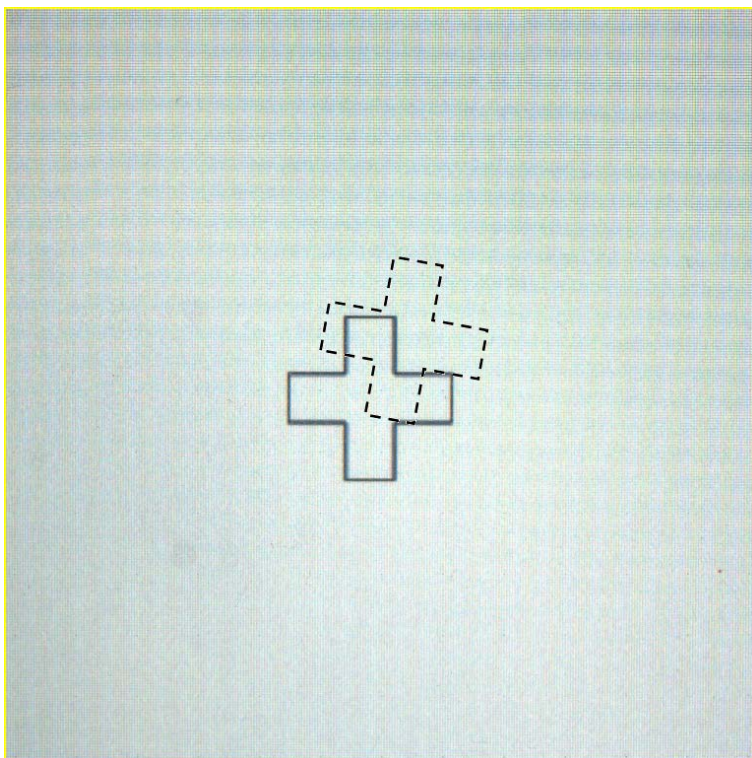

- 4) Add a new 1P Location inspection in the flow process. See Chapter 4 for the steps to create a flow process.

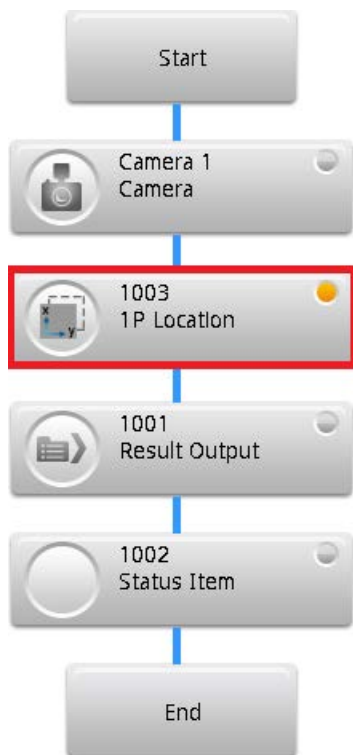

- 5) Click the icon on the left side of the 1P Location box to display the setup dialog box. Select the **Camera** and for the **Learning Method** select **11 Points Learning**. If the CCM is not completely configured, the button next to Learning Method is labeled **CCM is not ready**. Click this button to configure the coordinate conversion matrix.

W1003 1P Location	
Camera Setup	
Camera	Camera 1
Learning Method	11 Points Learning
	CCM is not ready
Target Search Setting	
1st Point	Shape
	Setup

- 6) The input parameters are dt, dx, and dy and dt represents the angle of rotation. If the angle of rotation is 10 degrees, you can directly enter 10.000. If both input dx and dy are 10 mm, you can directly enter 10.000 (as shown in the following diagram); however, the learning process fails if the feature exceeds the viewing region during the learning process. After entering the displacements, select the **Target Search Setting** tool (for example, Shape). Click **Setup** to configure the tool settings.

Learning Parameter Setting			
dt	<input type="text" value="10.000"/>	dx	<input type="text" value="10.000"/>
dy	<input type="text" value="10.000"/>	Following Arm	<input type="text" value="No"/>

Target Search Setting	
1st Point	<input type="text" value="Shape"/> <input type="button" value="Setup"/>

After configuring dx and dy, follow this learning path:

P1: X, Y

P2: X + (dx), Y

P3: X - (dx), Y

P4: X, (Y + dy)

P5: X, (Y - dy)

P6: X + (dx), Y + (dy)

P7: X - (dx), Y - (dy)

P8: X + (dx), Y - (dy)

P9: X - (dx), Y + (dy)

P10: X, Y, T + (dt)

P11: X, Y, T - (dt)

- 7) Click **Learning** when you complete the settings for the 1P Location. The system enters the learning mode and shows a progress bar on the screen that displays the learning progress. During the learning process, move the mechanical arm P1 with the DMV2000 triggered, then move the mechanical arm to P2 through P9 and trigger the DMV2000 at each point to completing the learning process.
- 8) Return to the 1P Location setup dialog box. Select the search tool (for example, Shape) under **Target Search Setting**, and then click **Setup** to configure the tool settings.

► Procedural Results

1P Location with 11 Points Learning returns the following inspection results:

- 1) **1P Location X:** outputs the relative X coordinate (relative to register image) of the target object using mechanical arm units.
- 2) **1P Location Y:** outputs the relative Y coordinate (relative to register image) of the target object using mechanical arm units.
- 3) **1P Location T:** outputs the relative angle (relative to register image) of the target object using mechanical arm units.

► Execution Result

The X, Y, and T values acquired for the 1P Location with 11 Points Learning are the relative coordinates of the target object respective to the register image and are output in mechanical arm units (as shown in the following diagram).

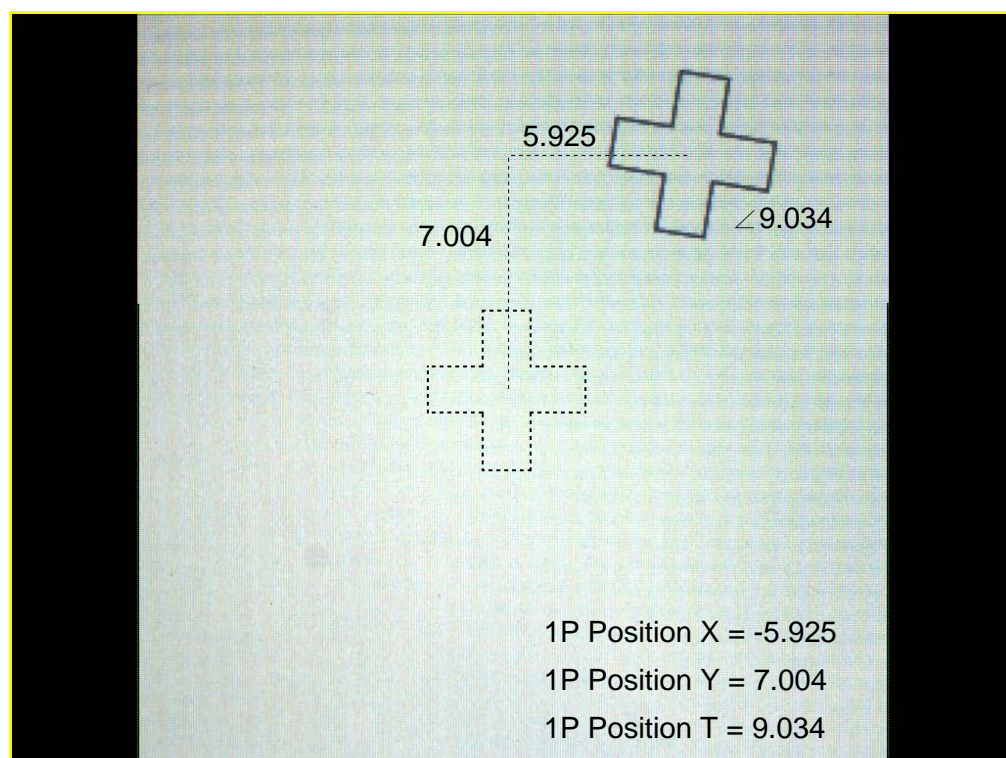

Chapter 6

Calculator, Result Output, Status Item

You can edit **Calculator**, **Result Output**, and **Status Item** only after you have completed configuring the **Inspections** in your flow process. See Chapter 4 for information on creating a flow process as part of an inspection project.

◎ **Calculator**

You can select numeric data from **Inspections** for arithmetic or function computations to get new values. The new values are available for subsequent **Output** functions. In addition, you can use this new data to configure the upper/lower limits in Calculator functions to obtain the Calculator ID-specific logic flag, and pass this result to subsequent **Output** functions.

◎ **Result Output**

You can select the resulting numeric data from **Inspection** and **Calculate** and the logic flags to output through any communication interface (for example, RS232, RS485, I/O, and Ethernet).

◎ **Status Item**

You can select the numeric data from **Inspection** and **Calculate** or logic flags to display in the LED menu on the Run Mode window to provide the operator an overview of the resulting inspection data.

6.1 What is a Calculator?

The Calculator function provides for a way to use mathematic operations to compute numeric data from Inspection results (such as numbers, coordinates, angles) and generate the required new results. For example, a calculator can add two counters with results 2 and 3 to get the final result, 5, which can then be used in a subsequent Output program (such as sending the numeric result 5 to the superior PC through RS232).

In addition to simple arithmetic, the Calculator also provides trigonometry functions, and functions for calculating the distance between coordinates.

Each inspection project independently supports up to 999 calculators, and you can configure upper and lower limits for each Calculator ID according to compare to the results to get the logic flag for the specific calculator. The system passes these results to subsequent logical Output options. For example, if an arithmetic computation produces a standard value of 100 (with +/-1 tolerance) pixels for a size measurement, the upper/lower limits of the calculator can be set to 101 and 99, respectively. Results between 99–101 are OK, and results not between 99–100 are NG.

6.2 Edit Calculator Functions

6.2.1 Calculator Interface

When you are editing the inspection process, click the icon in the **Calculator** box to enter the calculator function edit dialog box.

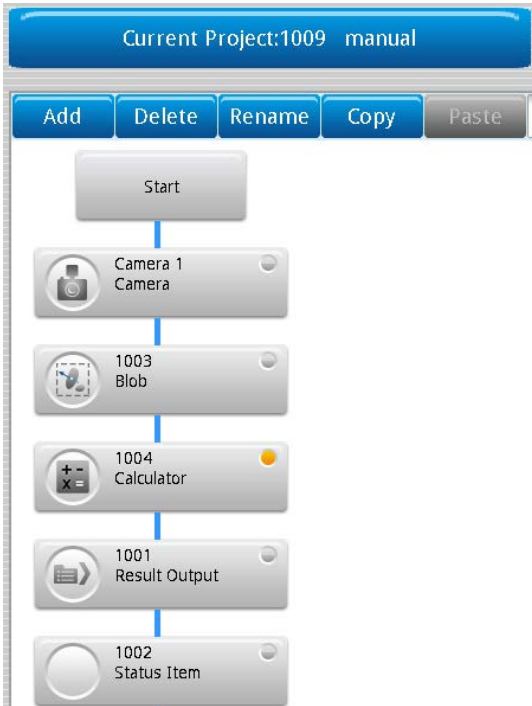

The following diagram shows a calculator edit dialog box in the Main window. The function of each region is explained below.

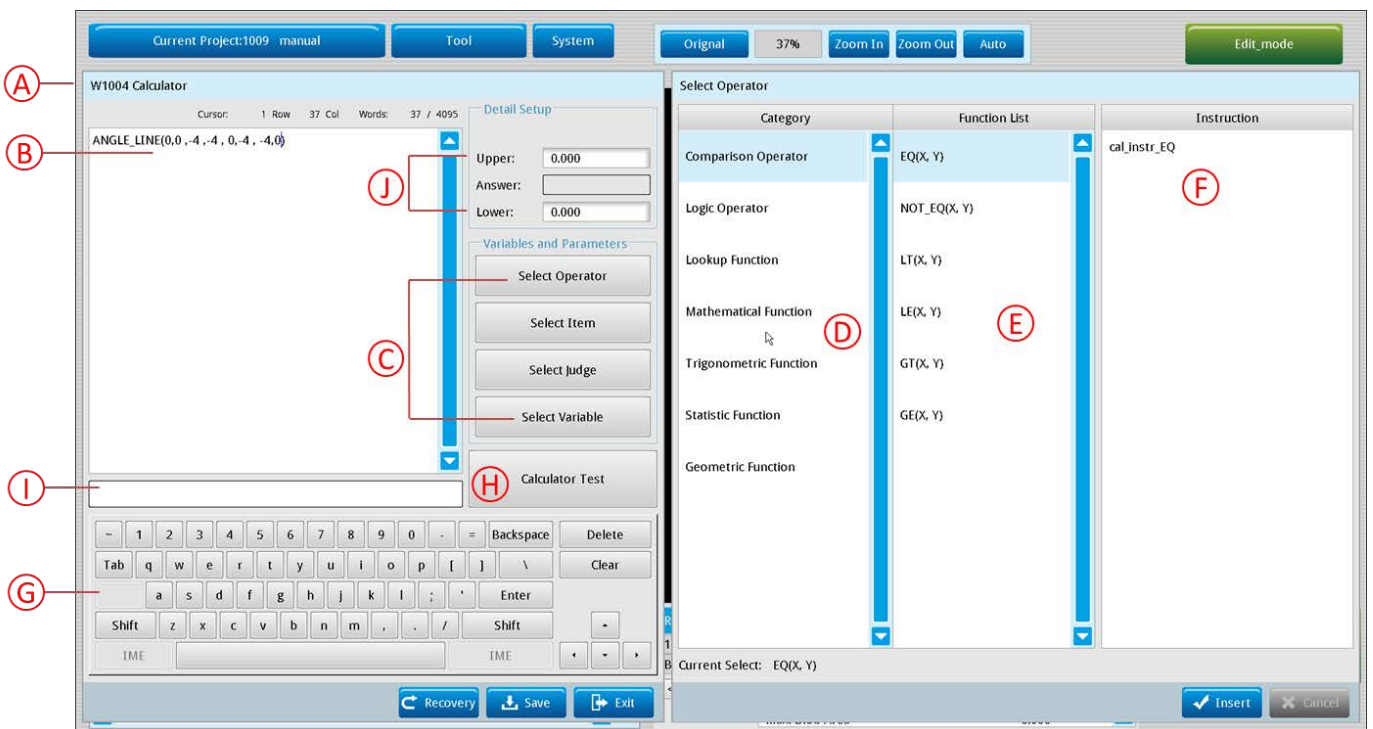

A. Calculator ID

You can configure multiple calculator functions (up to 999) for each project. The system automatically generates a number to identify each calculator.

B. Function display area

Displays the functions and equations you create.

C. Variables and Parameters buttons

Selects the mathematic function or inspection result to create the equation.

D. Category

Displays the options after you click one of the Variables and Parameters buttons.

For example, after you click **Select Operator**, multiple sublevel options, such as **Comparison Operator**, **Logic Operator**, and **Mathematical Function** appear in the **Category** area.

E. Function List

Displays the functions for the Category that you select. After selecting the previously mentioned Variables and Parameters and Type, each final function is displayed in Function List for your selection.

F. Instruction

Displays a description for the Function that you selected.

G. Keyboard

You must enter the text and numbers using this keyboard when editing functions.

H. & I. Calculator Test and Display Area

When you finish creating the function, click **Calculator Test** to confirm that the function is configured correctly. The calculator tests the syntax and configuration of the function and displays **The expression is correct** if the test result is correct. If the expression is not correct, the calculator displays **syntax error**.

J. Detail Setup

Configures the range of logical (Judge) conditions for this calculator. As shown in the following picture, you can configure the **Upper** and **Lower** range values for this calculator. For example, suppose the calculated result is 3. If you set Upper and Lower to 5 and 1, the logical (Judge) result for this calculator is OK (=1). If the calculated result is outside of the Upper–Lower range, the logical (Judge) result for this calculator is NG (=0). You can use the OK or NG results of this calculator for logical (Judge) decisions in subsequent processes.

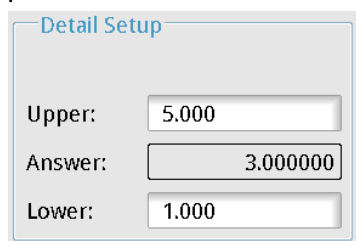

6.2.2 Variable and Parameter Functions

You can display all the required pieces for creating calculator equations by clicking the **Variables and Parameters** buttons.

⦿ **Select Operator** window

- As shown in the following diagram, the **Select Operator** window appears when you click **Select Operator**. It provides various categories of operators and functions. When you click a category of operators or functions, the corresponding operators or functions appear in the **Function List** column.
- The following diagram shows the Comparison Operator. The selected function is EQ (X, Y). After you insert the addition, the expression appears in the **Function Display Area**, and the values and inspection results are subsequently substituted into the function for calculations.

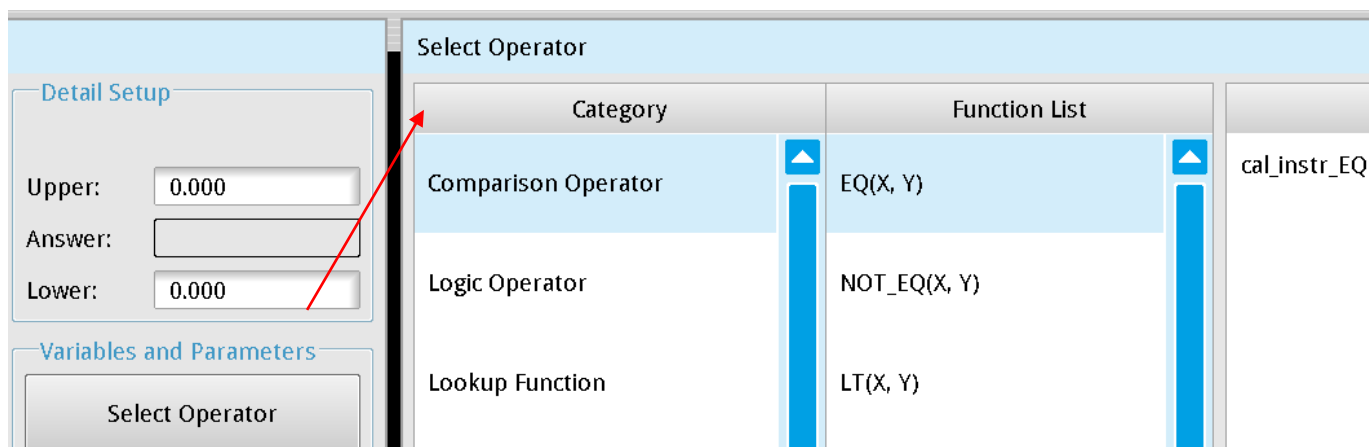

The 7 types of functions include Comparison Operator, Logic Operator, Lookup Function, Mathematical Function, Trigonometric Function, Statistic Function, and Geometric Function.

Chapter 6 Calculator, Result Output, and Status Item

The Comparison Operator functions: EQ, NOT_EQ, LT, LE, GT, GE

The Logic Operator functions: AND, BIT_AND, OR, BIT_OR, XOR, BIT_XOR, NOT, BIT_NOT

The Lookup Function functions: INRANGE, CHOOSE, MAXN, MINN, MAXthN, MINthN

The Mathematical Function functions: ABS, POW, MOD, LOG10, LN, EXP, SQR, SQRT, SUM, TRUNC, ROUND, CEIL, FLOOR

The Trigonometric Function functions: SIN, SINH, COS, COSH, TAN, TANH, ASIN, ACOS, ATAN, ATAN2, RAD, EDG, PI

The Statistic Function functions: MAX, AVG, AVG_RANGE, MIN, SDEV, MEDIAN

The Geometric Function functions: LINE_DIST, LINE_ISECT_X, LINE_ISECT_Y, CIRCLE_CX, CIRCLE_CY, CIRCLE_CR, ANGLE_H_POS, ANGLE_H_LINE, ANGLE_LINE, LINE_FITM, LINE_FITC, CIRCLE_FITD, CIRCLE_FITE, CIRCLE_FITF, POS_LINE_DIST, POS_LINE_DIST_X, POS_LINE_DIST_Y, POS_CIRCLE_DIST, ISEC_LINE_CIRCLE_CNT, ISEC_LINE_CIRCLE_X0, ISEC_LINE_CIRCLE_Y0, ISEC_LINE_CIRCLE_X1, ISEC_LINE_CIRCLE_Y1, ISEC_CIRCLE_CIRCLE_CNT, ISEC_CIRCLE_CIRCLE_X0, ISEC_CIRCLE_CIRCLE_Y0, ISEC_CIRCLE_CIRCLE_X1, ISEC_CIRCLE_CIRCLE_Y1

Comparison Operator			
Function	Description	Example	Note
EQ	Compares whether X and Y are equal	EQ(5,5) = 1	Outputs 1 if X and Y are equal; outputs 0 if X and Y differ
NOT_EQ	Compares whether X and Y differ	NOT_EQ(5,5) = 0	Outputs 1 if X and Y differ; outputs 0 if X and Y are equal
LT	Compares whether X<Y	LT(1,5) = 1	X<Y = 1; else 0
LE	Compares whether X<=Y	LE(1,1) = 1	X<=Y = 1; else 0
GT	Compares whether X>Y	GT(5,1) = 1	X>Y = 1; else 0
GE	Compares whether X>=Y	GE(1,1) = 1	X>=Y = 1; else 0

Logic Operator			
Function	Description	Example	Note
AND	AND gate	AND(1,1) = 1	The result will only be 1 when both are 1
BIT_AND	Numerical AND gate	BIT_AND(2,6) = 2	Performs AND after converting numerical value to bits 2 = 0010; 6 = 0110 BIT_AND = 0010
OR	OR gate	OR(1,0) = 1	Outputs 1 if any input is 1

BIT_OR	Numerical OR gate	BIT_OR(2,6) = 6	Performs OR after converting numerical value to bits 2 = 0010; 6 = 0110 BIT_OR = 0110
XOR	XOR gate	XOR(0,0) = 0 XOR(1,1) = 0 XOR(0,1) = 1 XOR(1,0) = 1	Output 0 if inputs match; output 1 if inputs differ.
BIT_XOR	Numerical XOR gate	BIT_XOR(2,6) = 4	Performs OR after converting numerical value to bits 2 = 0010; 6 = 0110 BIT_OR = 0100
NOT	NOT gate	NOT(0) = 1	0 gives an output of 1; 1 gives an output of 0.
BIT_NOT	Numerical NOT gate	BIT_NOT(6) = -7	The output is negative because bit 15 is 1.

Lookup Function			
Function	Description	Example	Note
INRANGE	(X,LL,UL) determines whether X is between LL and UL.	INRANGE(20,5,88) = 1	20 is between 5–88 and outputs a result of 1; else the function outputs 0.
CHOOSE	(M,X0...Xn) finds the value of M in the array	CHOOSE(4,88,56,100,2,25) = 25	4 means to acquire the 5th data
MAXN	(X0...Xn) finds the maximum value sorting index	MAXN(88,56,100,2,25) = 2	The 3rd data index is 2.
MINN	(X0...Xn) finds the minimum value sorting index	MINN(88,56,100,2,25) = 3	The 4th data index is 3.
MAXthN	(M,X0...Xn) finds the maximum value sorting index for the Mth value	MAXthN(2,88,56,100,2,25) = 0	The maximum value sorting index for 100 is 0.
MINthN	(M,X0...Xn) finds the minimum value sorting index for the Mth value	MINthN(2,88,56,100,2,25) = 4	The minimum value sorting index for 100 is 4.

Mathematical Function-			
Function	Description	Example	Note

Chapter 6 Calculator, Result Output, and Status Item

ABS	Absolute value	ABS(-10) = 10	
POW	Raised to the power N	POW(2,3) = 8 POW(3,4) = 81	$3 * 3 * 3 * 3 = 81$
MOD	Finds the remainder	MOD(5,2) = 1 MOD(8,3) = 2	$8 / 3 = 2$ remainder 2
LOG10	Calculates the logarithmic value	LOG10(10) = 1	
LN	Calculates the natural logarithmic value	LN(1) = 0	
EXP	Returns the exponential value	EXP(1) = 2.718281828...	
SQR	Square	SQR(2) = 4 SQR(-2) = 4	
SQRT	Square root	SQRT(9) = 3	
SUM	Calculates the sum of (X0... Xn)	SUM(1,2,3,4,5,) = 15	
TRUNC	Truncates	TRUNC(3.14) = 3	
ROUND	Rounds to integer	Round(1.55) = 2	
CEIL	Finds the nearest integer greater than X	CEIL(3.5) = 4 CEIL(-3.5) = -3	
FLOOR	Finds the nearest integer lesser than X	FLOOR(3.5) = 3 FLOOR(-3.5) = -4	

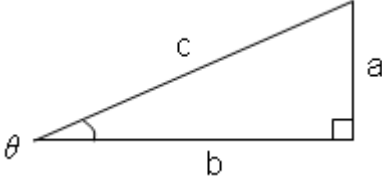
Trigonometric Function			
Function	Description	Example	Note
SIN	Sine	SIN(30) = 0.5	 <p> $\text{SIN}(\theta) = a / c$ $\text{COS}(\theta) = b / c$ $\text{TAN}(\theta) = a / b$ $\text{ASIN}(a/c) = \theta$ $\text{ACOS}(b/c) = \theta$ $\text{ATAN}(a/b) = \theta$ </p>
COS	Cosine	COS(30) = 0.866	
TAN	Tangent	TAN(30) = 0.577	
ASIN	Arcsine function	ASIN(1) = 90	
ACOS	Arccosine function	ACOS(1) = 0	
ATAN	Arctangent function	ATAN(1) = 45	
SINH	Hyperbolic sine function	SINH(1) = 1.1752011....	
COSH	Hyperbolic cosine function	COSH(1) = 1.5430806....	
TANH	Hyperbolic tangent function	TANH(1) = 0.7615941....	
ATAN2	(X,Y) arctangent	ATAN2(1,1) = 45	

	trigonometric function (X/Y)	
RAD	Converts to radians	RAD(180) = 3.14
DEG	Converts to degrees	DEG(3.14) = 179.90
PI	π constant	3.14159

Statistic Function			
Function	Description	Example	Note
MAX	Finds the maximum in (X0...Xn)	MAX(88,56,100,2,25) = 100	
AVG	Finds the average in (X0...Xn)	AVG(88,56,100,2,25) = 54.199...	
AVG_RANGE	(LL,UL,X0...Xn) Calculates the average between LL and UL	AVG_RGANGE(50,90,88,56,100,2,25) = 72	
MIN	Finds the minimum in (X0...Xn)	MIN(88,56,100,2,25) = 2	
SDEV	Calculates the standard deviation of (X0...Xn)	SDEV(5,6,8,9) = 1.5811388...	
MEDIAN	Calculates the median of (X0...Xn)	MEDIAN(88,56,100,2,25) = 56	Take the smaller value when there are 2 medians

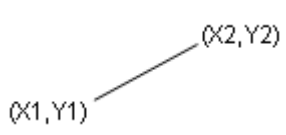
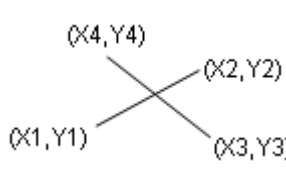
Geometric Function			
Function	Description	Example	Note
LINE_DIST	(X1,Y1,X2,Y2) Distance between two points	DIST(20,20,30,20) = 10 DIST(20,20,30,30) = 14.14	
LINE_ISECT_X	(X1,Y1,X2,Y2,X3,Y3,X4,Y4) X coordinates of intersection between two lines	ISECT_X(0,0,4,4,0,4,4,0) = 2	
LINE_ISECT_Y	(X1,Y1,X2,Y2,X3,Y3,X4,Y4) Y coordinates of intersection between two lines	ISECT_Y(0,0,4,4,0,4,4,0) = 2	
CIRCLE_CX	(X1,Y1,X2,Y2,X3,Y3)	CIRCLE_X(-14.6,8.94,-11.64,4.15,-	

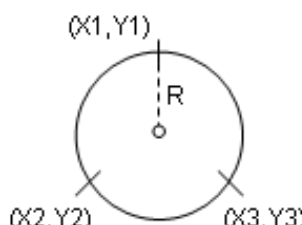
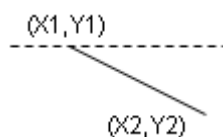
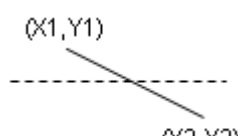
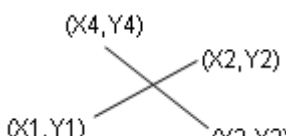
	Y3) X coordinates of circle formed by three points	$15.61, 3.47) = -14$	
CIRCLE_CY	(X1,Y1,X2,Y2,X3,Y3) Y coordinates of circle formed by three points	$CIRCLE_Y(-14.6, 8.94, -11.64, 4.15, -15.61, 3.47) = 6$	
CIRCLE_CR	(X1,Y1,X2,Y2,X3,Y3) Radius (R) of circle formed by three points	$CIRCLE_R(-14.6, 8.94, -11.64, 4.15, -15.61, 3.47) = 3$	
ANGLE_H_POS	(X1,Y1,X2,Y2) Angle between a line formed by two coordinates and the horizontal surface (connected at X1,Y1) In clockwise direction (range +/-180°)	$ANGLE(0,0,5,5) = 45$ $ANGLE(5,5,0,0) = -135$	
ANGLE_H_LINE	(X1,Y1,X2,Y2) Incident angle of line to horizontal axis In clockwise direction (range +/-90°)	$LINE_ANGLE(5,5,0,0) = 45$	
ANGLE_LINE	(X1,Y1,X2,Y2,X3,Y3,X4,Y4) Acute angle of two intersecting lines	$D_LINE_ANGLE(0,0,4,4,0,4,4,0) = 90$	
LINE_FITM	(X1,Y1,X2,Y2) Linear equation $Y=mX+c$	$LINE_FITM(1,1,3,2) = 0.5$	Return result m

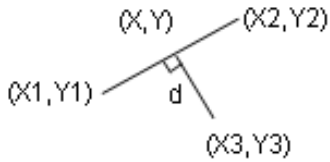
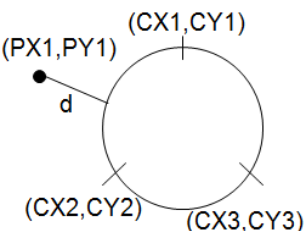
LINE_FITC	(X1,Y1,X2,Y2) Linear equation $Y=mX+c$	LINE_FITC(1,1,3,2) = 0.5	Return result c
CIRCLE_FITD	(X1,Y1,X2,Y2,X3, Y3) Equation of the circle $X*X+Y*Y+dX+eY$ $+f=0$	CIRCLE_FITD(0,2,2,0,4,2) = -4	Return result c
CIRCLE_FITE	(X1,Y1,X2,Y2,X3, Y3) Equation of the circle $X*X+Y*Y+dX+eY$ $+f=0$	CIRCLE_FITE(0,2,2,0,4,2) = -4	Return result e
CIRCLE_FITF	(X1,Y1,X2,Y2,X3, Y3) Equation of the circle $X*X+Y*Y+dX+eY$ $+f=0$	CIRCLE_FITF(0,2,2,0,4,2) = 4	Return result f
POS_LINE_DIST	(X1,Y1,X2,Y2,X3, Y3) Minimum distance (d) between a line and a point	LINE_DIST(0,0,4,4,0,4) = 2	
POS_LINE_DIST_X	(X1,Y1,X2,Y2,X3, Y3) X coordinates on the line with min distance to a point	LINE_DIST_X(0,0,4,4,0,4) = 2	
POS_LINE_DIST_Y	(X1,Y1,X2,Y2,X3, Y3) Y coordinates on the line with min distance to a point	LINE_DIST_Y(0,0,4,4,0,4) = 2	
POS_CIRCLE_DIST	(PX1,PY1,CX1,C Y1,CX2,CY2,CX3 ,CY3) The minimum distance from a coordinate point to the	POS_CIRCLE_DIST(7,2,2,0,0,2,2, 4) = 3	



	circumference		
ISEC_LINE_CIRCLE_CNT	(PX1,PY1,PX2,PY2,CX1,CY1,CX2,CY2,CX3,CY3) Number of intersections between a line generated by two points and the circle	ISEC_LINE_CIRCLE_CNT(1,1,6,6,0,3,3,0,6,3) = 2	
ISEC_LINE_CIRCLE_X0	(PX1,PY1,PX2,PY2,CX1,CY1,CX2,CY2,CX3,CY3) The coordinate of the first intersection (X0) between a line generated by two points and the circle	ISEC_LINE_CIRCLE_X0(1,1,6,6,0,3,3,0,6,3) = 0.8786796...	
ISEC_LINE_CIRCLE_Y0	(PX1,PY1,PX2,PY2,CX1,CY1,CX2,CY2,CX3,CY3) The coordinate of the first intersection (Y0) between a line generated by two points and the circle	ISEC_LINE_CIRCLE_Y0(1,1,6,6,0,3,3,0,6,3) = 0.8786796...	
ISEC_LINE_CIRCLE_X1	(PX1,PY1,PX2,PY2,CX1,CY1,CX2,CY2,CX3,CY3) The coordinate of the second intersection (X1) between a line generated by two points and the circle	ISEC_LINE_CIRCLE_X1(1,1,6,6,0,3,3,0,6,3) = 5.1213203...	

<p>ISEC_LINE_CIRCLE_Y1</p>	<p>(PX1,PY1,PX2,PY2,CX1,CY1,CX2,CY2,CX3,CY3) The coordinate of the second intersection (Y1) between a line generated by two points and the circle</p>	<p>ISEC_LINE_CIRCLE_Y1(1,1,6,6,0,3,3,0,6,3) = 5.1213203...</p>	
<p>ISEC_CIRCLE_CIRCLE_CNT</p>	<p>(C1X1,C1Y1,C1X2,C1Y2,C1X3,C1Y3,C2X1,C2Y1,C2X2,C2Y2,C2X3,C2Y3) Number of intersections between two circles</p>	<p>ISEC_CIRCLE_CIRCLE_CNT(0,2,2,0,4,2,0,2,2,0,-2,0) = 2</p>	
<p>ISEC_CIRCLE_CIRCLE_X0</p>	<p>(C1X1,C1Y1,C1X2,C1Y2,C1X3,C1Y3,C2X1,C2Y1,C2X2,C2Y2,C2X3,C2Y3) The coordinate of the first intersection (X0) between two circles</p>	<p>ISEC_CIRCLE_CIRCLE_X0(0,2,2,0,4,2,0,2,2,0,-2,0) = 0</p>	
<p>ISEC_CIRCLE_CIRCLE_Y0</p>	<p>(C1X1,C1Y1,C1X2,C1Y2,C1X3,C1Y3,C2X1,C2Y1,C2X2,C2Y2,C2X3,C2Y3) The coordinate of the first intersection (Y0) between two circles</p>	<p>ISEC_CIRCLE_CIRCLE_Y0(0,2,2,0,4,2,0,2,2,0,-2,0) = 2</p>	
<p>ISEC_CIRCLE_C</p>	<p>(C1X1,C1Y1,C1X</p>	<p>ISEC_CIRCLE_CIRCLE_X1(0,2,2,</p>	

IRCLE_X1	2,C1Y2,C1X3,C1Y3,C2X1,C2Y1,C2X2,C2Y2,C2X3,C2Y3) The coordinate of the second intersection (X1) between two circles	0,4,2,0,2,2,0,-2,0)= 2	
ISEC_CIRCCLE_CIRCLE_Y1	(C1X1,C1Y1,C1X2,C1Y2,C1X3,C1Y3,C2X1,C2Y1,C2X2,C2Y2,C2X3,C2Y3) The coordinate of the second intersection (Y1) between two circles	ISEC_CIRCLE_CIRCLE_Y1(0,2,2,0,4,2,0,2,2,0,-2,0) = 0	

Remark A comma separates the elements. For example: AVG(2,3,4)

◎ **The Select Item window**

- As shown in the following diagram, the **Select Item Unit** column displays the **Inspections** in the project, including not only the configured inspections (windows) but also **Calculator** units.
- Using the Blob unit as an example, the Blob tool generates multiple result items after Blob inspection. This means that numerous options are available in the **Parameter** column (such as Number of Blobs, Blob Centroid Position X).
- In **Parameter** column, the  symbol means that an additional **Parameter** option is required (for example, Blob Centroid Position X has the  symbol because the sorting function configured for the Blob tool can identify multiple blobs with reference sequence numbers (meaning multiple centroid X coordinates). Therefore, you must select the resulting value based on the configurations.

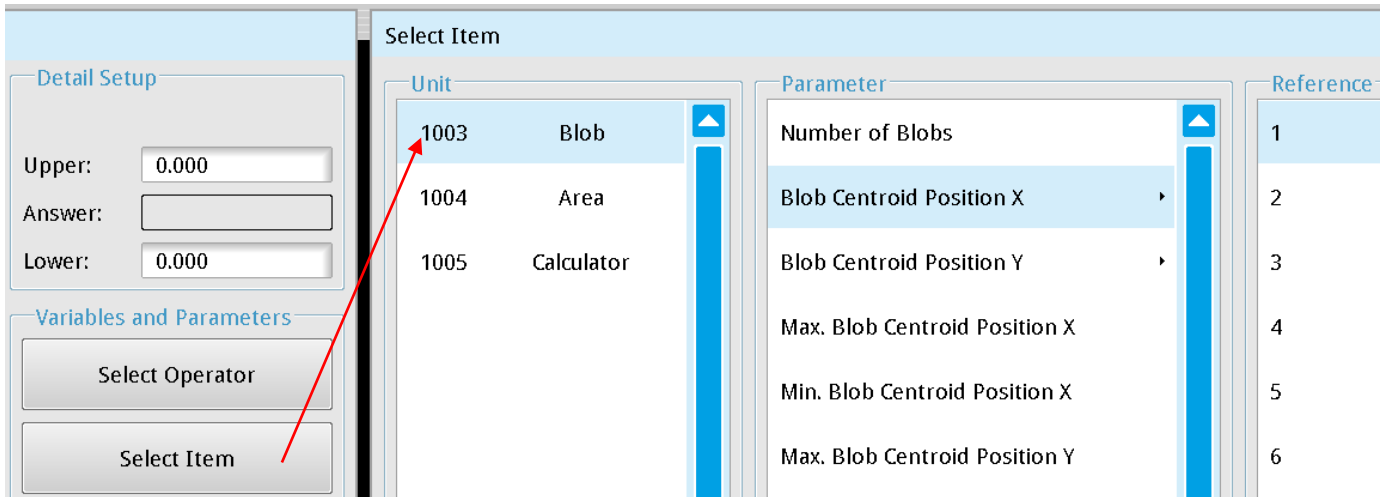

Data format

Data format and representation is explained using (Edge Position - X coordinate) WIN(□□□□,X,ΔΔ) as an example.

□□□□: Represents the nth function unit. For example: 1005 represents the 5th function unit in Flow Process 1.

[ΔΔ]: Represents using the nth result as the output. For example, WIN1005 detected 3 edge positions. If [ΔΔ] is configured to 2, the result from the second edge is used as the calculation (output) content.

X: Represents the results that are the contents of the X coordinate; please refer to the following table for the result codes for each inspection function.

Inspection Function	Syntax	Description	Reference	Calculator data format
Area	TAR	Total area	--	WIN(□□□□,TAR,0)
Position	N	Quantity	--	WIN(□□□□,N,0)
	X	X coordinate	[ΔΔ]	WIN(□□□□,X,ΔΔ)
	Y	Y coordinate	[ΔΔ]	WIN(□□□□,Y,ΔΔ)
	AG	Absolute Angle (0° in the horizontal direction) of ring and arc	[ΔΔ]	WIN(□□□□,AG,ΔΔ)
	RA	Relative edge angle (to initial inspection angle) of ring and arc	[ΔΔ]	WIN(□□□□,RA,ΔΔ)
Count	N	Number of edges	--	WIN(□□□□,N,0)
Width	L	Width (unit: pixels or degrees)	--	WIN(□□□□,L,0)
	X1	X coordinates of first edge	--	WIN(□□□□,X1,0)
	Y1	Y coordinates of first edge	--	WIN(□□□□,Y1,0)
	AG1	Absolute angle 1 of circle and arc	--	WIN(□□□□,AG1,0)
	RA1	Relative angle 1 of circle and arc	--	WIN(□□□□,RA1,0)
	X2	X coordinates of second edge	--	WIN(□□□□,X2,0)
	Y2	Y coordinates of second edge	--	WIN(□□□□,Y2,0)
AG2	Absolute angle 2 of circle and arc	--	WIN(□□□□,AG2,0)	

Chapter 6 Calculator, Result Output, and Status Item

	RA2	Relative angle 2 of circle and arc	--	WIN(□□□□,RA2,0)
Pitch	N	Quantity	--	WIN(□□□□,N,0)
	W	Pitch (unit: pixels or degrees)	[ΔΔ]	WIN(□□□□,W,ΔΔ)
	WH	Maximum pitch (unit: pixels or degrees)	--	WIN(□□□□,WH,0)
	WL	Minimum pitch (unit: pixels or degrees)	--	WIN(□□□□,WL,0)
	WA	Average pitch (unit: pixels or degrees)	--	WIN(□□□□,WA,0)
	XS	X coordinates of first edge	[ΔΔ]	WIN(□□□□,XS,ΔΔ)
	YS	Y coordinates of first edge	[ΔΔ]	WIN(□□□□,YS,ΔΔ)
	AGS	Absolute angle 1 of circle and arc	[ΔΔ]	WIN(□□□□,AGS,ΔΔ)
	RAS	Relative angle 1 of circle and arc	[ΔΔ]	WIN(□□□□,RGS,ΔΔ)
	XE	X coordinates of second edge	[ΔΔ]	WIN(□□□□,XE,ΔΔ)
	YE	Y coordinates of second edge	[ΔΔ]	WIN(□□□□,YE,ΔΔ)
	AGE	Absolute angle 2 of circle and arc	[ΔΔ]	WIN(□□□□,AGE,ΔΔ)
	RAE	Relative angle 2 of circle and arc	[ΔΔ]	WIN(□□□□,RAE,ΔΔ)
	X	X coordinates of pitch center	[ΔΔ]	WIN(□□□□,X,ΔΔ)
	Y	Y coordinates of pitch center	[ΔΔ]	WIN(□□□□,Y,ΔΔ)
AG	Absolute angle of edge center of circle and arc	[ΔΔ]	WIN(□□□□,AG,ΔΔ)	
Angle	EAG	Angle (0° in the horizontal direction)	--	WIN(□□□□,EAG,0)
	X1	X coordinates of top angle	--	WIN(□□□□,X1,0)
	Y1	Y coordinates of top angle	--	WIN(□□□□,Y1,0)
	X2	X coordinates of bottom angle	--	WIN(□□□□,X2,0)
	Y2	Y coordinates of bottom angle	--	WIN(□□□□,Y2,0)
Intensity	IA	Average brightness	--	WIN(□□□□,IA,0)
	ID	Standard brightness deviation	--	WIN(□□□□,ID,0)
	IH	Maximum brightness	--	WIN(□□□□,IH,0)
	IL	Minimum brightness	--	WIN(□□□□,IL,0)
Shape Comparison	N	Quantity	--	WIN(□□□□,N,0)
	S	Similarity	[ΔΔ]	WIN(□□□□,S,ΔΔ)
	X	X coordinates of found object	[ΔΔ]	WIN(□□□□,X,ΔΔ)
	Y	Y coordinates of found object	[ΔΔ]	WIN(□□□□,Y,ΔΔ)
	XH	Maximum X coordinates from all objects	--	WIN(□□□□,XH,0)
	XL	Minimum X coordinates from all objects	--	WIN(□□□□,XL,0)
	YH	Maximum Y coordinates from all objects	--	WIN(□□□□,YH,0)
	YL	Minimum Y coordinates from all objects	--	WIN(□□□□,YL,0)
AG	Object angle found	[ΔΔ]	WIN(□□□□,AG,ΔΔ)	
Pattern Comparison	N	Quantity	--	WIN(□□□□,N,0)
	S	Similarity	[ΔΔ]	WIN(□□□□,S,ΔΔ)
	X	X coordinates of found object	[ΔΔ]	WIN(□□□□,X,ΔΔ)

	Y	Y coordinates of found object	[ΔΔ]	WIN(□□□□,Y,ΔΔ)
	XH	Maximum X coordinates from all objects	--	WIN(□□□□,XH,0)
	XL	Minimum X coordinates from all objects	--	WIN(□□□□,XL,0)
	YH	Maximum Y coordinates from all objects	--	WIN(□□□□,YH,0)
	YL	Minimum Y coordinates from all objects	--	WIN(□□□□,YL,0)
	AG	Object angle found	[ΔΔ]	WIN(□□□□,AG,ΔΔ)
Blob	N	Quantity	--	WIN(□□□□,N,0)
	X	Center X coordinates	[ΔΔ]	WIN(□□□□,X,ΔΔ)
	Y	Center Y coordinates	[ΔΔ]	WIN(□□□□,Y,ΔΔ)
	XH	Maximum X coordinates of all spot centers	--	WIN(□□□□,XH,0)
	XL	Minimum X coordinates of all spot centers	--	WIN(□□□□,XL,0)
	YH	Maximum Y coordinates of all spot centers	--	WIN(□□□□,YH,0)
	YL	Minimum Y coordinates of all spot centers	--	WIN(□□□□,YL,0)
	AR	Blob area	[ΔΔ]	WIN(□□□□,AR,ΔΔ)
	ARH	Maximum blob area	--	WIN(□□□□,ARH,0)
	ARL	Minimum blob area	--	WIN(□□□□,ARL,0)
	RD	Roundness	[ΔΔ]	WIN(□□□□,RD,ΔΔ)
	RDH	Maximum roundness	--	WIN(□□□□,RDH,0)
	RDL	Minimum roundness	--	WIN(□□□□,RDL,0)
	AG	Incident clockwise angle of main axis to horizontal axis	[ΔΔ]	WIN(□□□□,AG,ΔΔ)
	AGH	Maximum incident clockwise angle of all main axis to horizontal axis	--	WIN(□□□□,AGH,0)
	AGL	Minimum incident clockwise angle of all main axis to horizontal axis	--	WIN(□□□□,AGL,0)
	PE	Circumference	[ΔΔ]	WIN(□□□□,PE,ΔΔ)
	PEH	Maximum circumference	--	WIN(□□□□,PEH,0)
	PEL	Minimum circumference	--	WIN(□□□□,PEL,0)
	EX	X (horizontal direction) Feret diameter	[ΔΔ]	WIN(□□□□,EX,ΔΔ)
	EY	Y (vertical direction) Feret diameter	[ΔΔ]	WIN(□□□□,EY,ΔΔ)
	EXH	Maximum X (horizontal) Feret diameter	--	WIN(□□□□,EXH,0)
	EXL	Minimum X (horizontal) Feret diameter	--	WIN(□□□□,EXL,0)
	EYH	Maximum Y (vertical) Feret diameter	--	WIN(□□□□,EYH,0)
	EYL	Minimum Y (vertical) Feret diameter	--	WIN(□□□□,EYL,0)
	TLX	Top left X coordinates of extension rectangle	[ΔΔ]	WIN(□□□□,TLX,ΔΔ)
TLY	Top left Y coordinates of extension rectangle	[ΔΔ]	WIN(□□□□,TLY,ΔΔ)	
MA	Major axis length	[ΔΔ]	WIN(□□□□,MA,ΔΔ)	

Chapter 6 Calculator, Result Output, and Status Item

	MAH	Maximum major axis length	--	WIN(□□□□,MAH,0)
	MAL	Minimum major axis length	--	WIN(□□□□,MAL,0)
Stain	TAR	Total defective area	--	WIN(□□□□,N,0)
	N	Cluster	--	WIN(□□□□,N,0)
	AR	Defective area	[ΔΔ]	WIN(□□□□,AR,ΔΔ)
	ARH	Maximum defective area	--	WIN(□□□□,ARH,0)
	ARL	Minimum defective area	--	WIN(□□□□,ARL,0)
	X	Center X coordinates of all defects	[ΔΔ]	WIN(□□□□,X,ΔΔ)
	Y	Center Y coordinates of all defects	[ΔΔ]	WIN(□□□□,Y,ΔΔ)
	XH	Maximum X coordinates from all defect centers	--	WIN(□□□□,XH,0)
	XL	Minimum X coordinates from all defect centers	--	WIN(□□□□,XL,0)
	YH	Maximum Y coordinates from all defect centers	--	WIN(□□□□,YH,0)
YL	Minimum Y coordinates from all defect centers	--	WIN(□□□□,YL,0)	
Position Trace	N	Total	--	WIN(□□□□,N,0)
	X	X coordinates of all edges	[ΔΔ]	WIN(□□□□,X,ΔΔ)
	Y	Y coordinates of all edges	[ΔΔ]	WIN(□□□□,Y,ΔΔ)
	XH	X coordinates of maximum outline	--	WIN(□□□□,XH,0)
	XL	X coordinates of minimum outline	--	WIN(□□□□,XL,0)
	YH	Y coordinates of maximum outline	--	WIN(□□□□,YH,0)
	YL	Y coordinates of minimum outline	--	WIN(□□□□,YL,0)
	XA	Average X coordinates of all outlines	--	WIN(□□□□,XA,0)
	YA	Average Y coordinates of all outlines	--	WIN(□□□□,YA,0)
	D	Distances of all outlines	[ΔΔ]	WIN(□□□□,D,ΔΔ)
	DH	Maximum distance from all outlines	--	WIN(□□□□,DH,0)
	DL	Minimum distance from all outlines	--	WIN(□□□□,DL,0)
	DA	Average distance from all outlines	--	WIN(□□□□,DA,0)
	RD	Roundness	--	WIN(□□□□,RD,0)
	Width Trace	N	Total	--
WH		Maximum width	--	WIN(□□□□,WH,0)
WL		Minimum width	--	WIN(□□□□,WL,0)
WA		Average width	--	WIN(□□□□,WA,0)
W		All widths	[ΔΔ]	WIN(□□□□,W,ΔΔ)

	HX1	X1 coordinates of maximum width	--	WIN(□□□□,HX1,0)
	HY1	Y1 coordinates of maximum width	--	WIN(□□□□,HY1,0)
	HX2	X2 coordinates of maximum width	--	WIN(□□□□,HX2,0)
	HY2	Y2 coordinates of maximum width	--	WIN(□□□□,HY2,0)
	LX1	X1 coordinates of minimum width	--	WIN(□□□□,LX1,0)
	LY1	Y1 coordinates of minimum width	--	WIN(□□□□,LY1,0)
	LX2	X2 coordinates of minimum width	--	WIN(□□□□,LX2,0)
	LY2	Y2 coordinates of minimum width	--	WIN(□□□□,LY2,0)
	XS	X1 coordinates of width across all edges	[ΔΔ]	WIN(□□□□,XS,ΔΔ)
	YS	Y1 coordinates of width across all edges	[ΔΔ]	WIN(□□□□,YS,ΔΔ)
	XE	X2 coordinates of width across all edges	[ΔΔ]	WIN(□□□□,XE,ΔΔ)
	YE	Y2 coordinates of width across all edges	[ΔΔ]	WIN(□□□□,YE,ΔΔ)
	RD1	Roundness 1 (inner)	--	WIN(□□□□,RD1,0)
	CX1	Roundness center position X1	--	WIN(□□□□,CX1,0)
	CY1	Roundness center position Y1	--	WIN(□□□□,CY1,0)
	CR1	Roundness radius 1	--	WIN(□□□□,CR1,0)
	RD2	Roundness 2 (outer)	--	WIN(□□□□,RD2,0)
	CX2	Centre X coordinates of circle 2	--	WIN(□□□□,CX2,0)
	CY2	Centre Y coordinates of circle 2	--	WIN(□□□□,CY2,0)
	CR2	Circle 2 radius	--	WIN(□□□□,CR2,0)
1P Position	X	X coordinates of found object	[ΔΔ]	WIN(□□□□, X, ΔΔ)
	Y	Y coordinates of found object	[ΔΔ]	WIN(□□□□, Y, ΔΔ)
	T	Object angle found	[ΔΔ]	WIN(□□□□, T, ΔΔ)
	CNT	Number of objects found	--	WIN(□□□□, CNT, 0)
	S	Similarity of objects found	[ΔΔ]	WIN(□□□□, S, ΔΔ)
	OX	Image X coordinate of the object found	[ΔΔ]	WIN(□□□□, OX, ΔΔ)
	OY	Image Y coordinate of the object found	[ΔΔ]	WIN(□□□□, OY, ΔΔ)
1P Location	X	Offset in X coordinate of the object found	[ΔΔ]	WIN(□□□□, X, ΔΔ)
	Y	Offset in Y coordinate of the object found	[ΔΔ]	WIN(□□□□, Y, ΔΔ)
	T	Offset in angle of the object found	[ΔΔ]	WIN(□□□□, T, ΔΔ)
	CNT	Number of objects found	--	WIN(□□□□, CNT, 0)
	S	Similarity score of objects found	[ΔΔ]	WIN(□□□□, S, ΔΔ)
	OX	Offset in image X coordinate of the object found	[ΔΔ]	WIN(□□□□, OX, ΔΔ)
	OY	Offset in image Y coordinate of the object found	[ΔΔ]	WIN(□□□□, OY, ΔΔ)

◎ The Select Judge Window

- **Select Judge** generally carries out Boolean operations in coordination with the previously mentioned **Logic Operator** function under **Select Operator**.

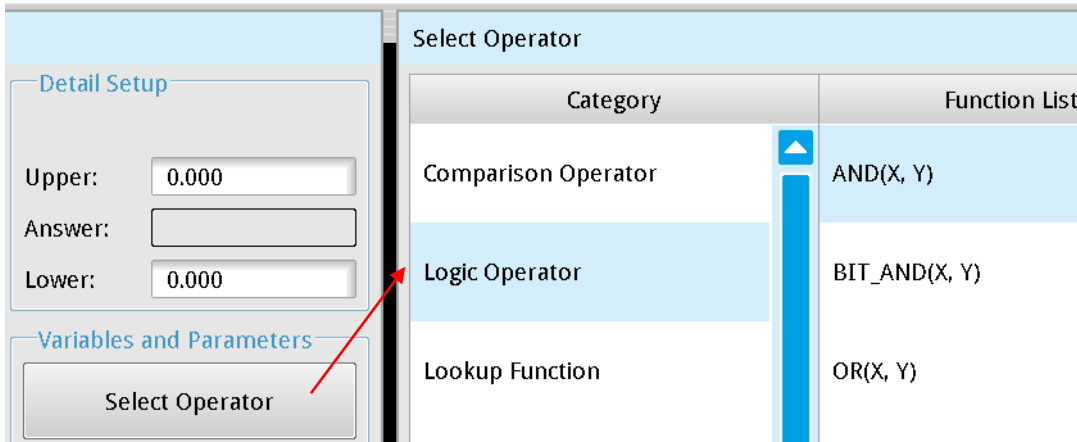

- As shown in the following diagram, the **Select Judge Unit** column displays the **Inspections** in the project, including not only the configured inspections (windows) but also **Calculator** units.
- Using the Blob unit as an example, the Blob tool generates multiple result items after Blob inspection. This means that numerous options are available in the **Parameter** column (for example, Number of Blobs and Blob Centroid Position X).
- In **Parameter** options, the ► symbol means that an additional **Parameter** option is required (for example, Blob Centroid Position X has the ► symbol because the sorting function configured for the Blob tool can identify multiple blobs with reference sequence numbers (meaning multiple centroid X coordinates). Therefore, you must select the resulting value based on the configurations.

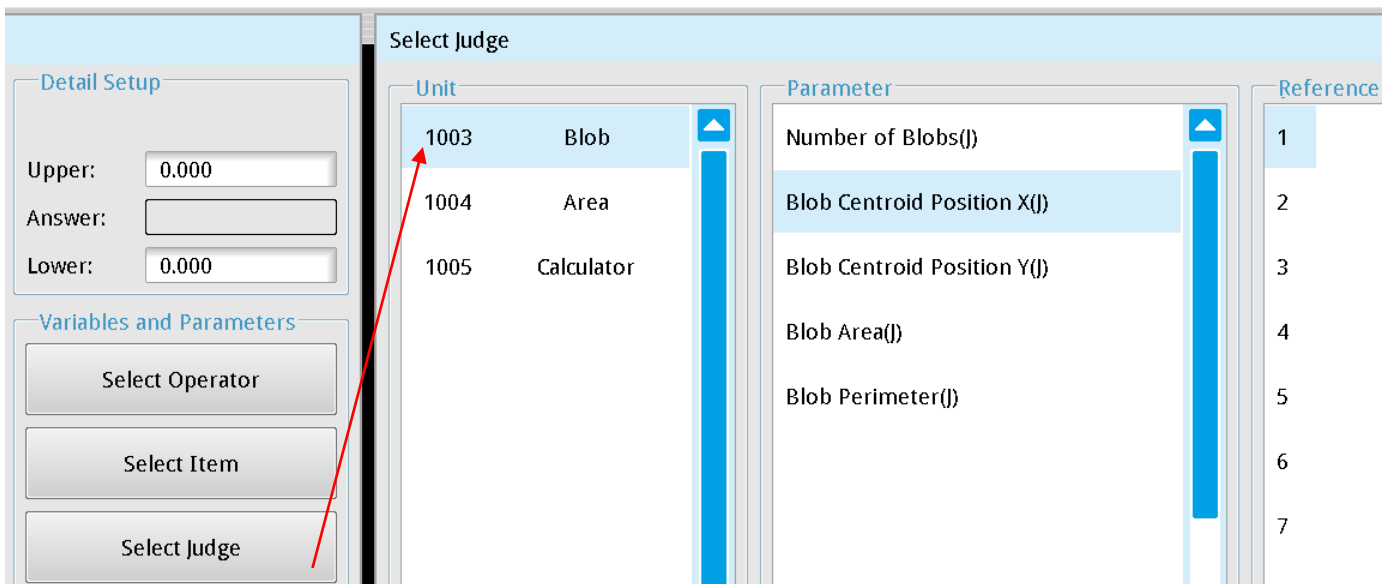

- In the **Select Judge** window, you can select the logical (Judge) result from **Inspections** and also results from **Calculator** and use in Boolean operations.

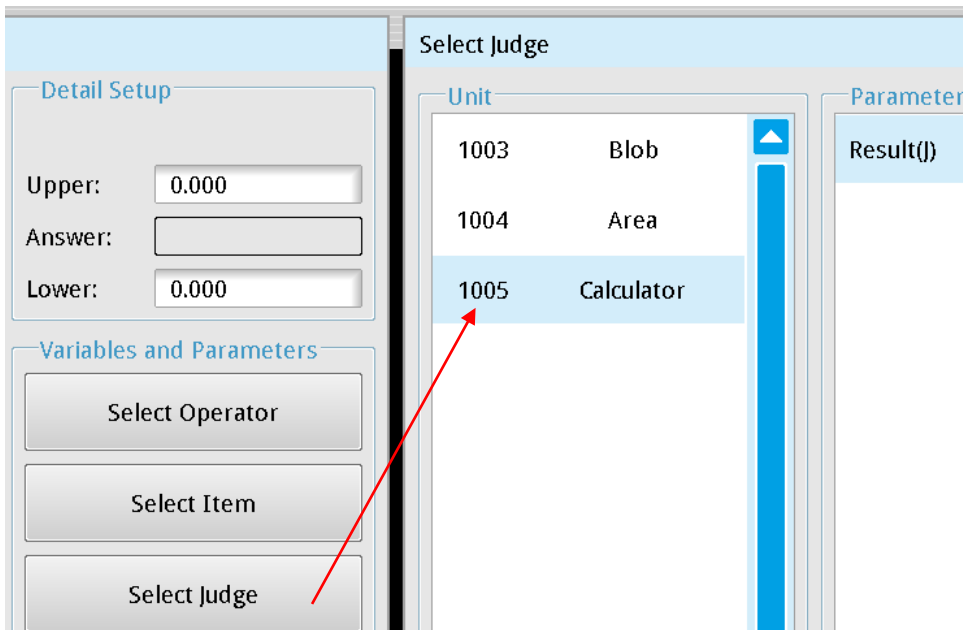

- Generating logical results
- ◆ The system generates the logical Inspection results (OK=1; NG=0) by comparing results based on the Limits that you set for each Inspection function (see the following diagram).
- ◆ The system generates the logical Inspection results (OK=1; NG=0) by comparing results based on the Detail Setup that you set for each Calculator (see the following diagram).

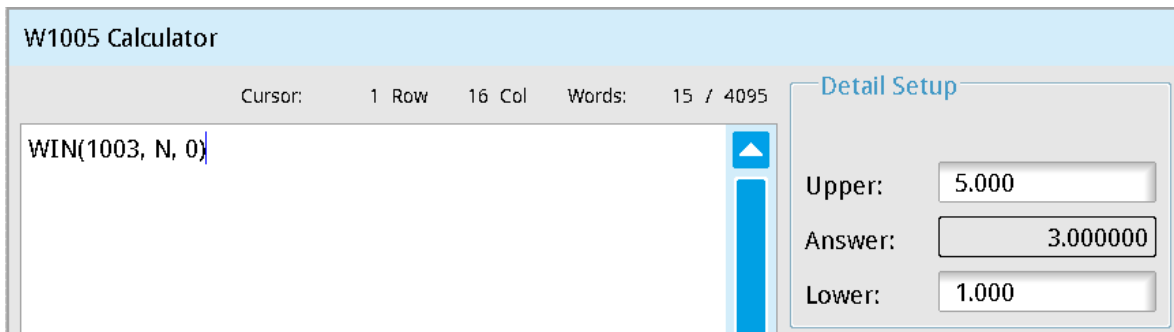

- The final inspection result is usually generated through several logical (OK/NG) Inspections results. Therefore, you can use the logical OK(1)/NG(0) result from Select Judge + Select Operator > Logic Operator to execute operations that generate the final logical (Judge) result. For example, suppose you want the output result to be OK only when all three Inspections are OK. Use AND from the logic operators to process the 3 inspection results (A AND B AND C). Similarly, use OR from the logic operators to combine three inspections to generate the OK result when at least one inspection item must be OK.

Chapter 6 Calculator, Result Output, and Status Item

Data format

The data format and representation is explained using (Edge Position - X coordinate) JUG(□□□□,X,△△) as an example.

□□□□: Represents the nth inspection function For example: 1005 represents the 5th inspection function

[△△]: Represents using the nth sorting result as the output For example, 1005 detected three edge positions. If [△△] is configured to 2, the logical OK/NG result from the second edge is used as the calculated value.

X: Represents the logical (Judge) result of the X coordinate; please see the following table for the codes for each inspection function

Inspection Function	Syntax	Description	Reference	Judge Data format
Area	TAR	Total area	--	JUG(□□□□,TAR,0)
Position	X	X coordinate	[△△]	JUG(□□□□,X,△△)
	Y	Y coordinate	[△△]	JUG(□□□□,Y,△△)
	AG	Absolute angle (0° in the horizontal direction) of ring and arc	[△△]	JUG(□□□□,AG,△△)
Count	N	Number of edges	--	JUG(□□□□,N,0)
Width	W	Width (unit in pixels or degrees)	--	JUG(□□□□,W,0)
	X	X coordinates of first edge	--	JUG(□□□□,X,0)
	Y	Y coordinates of first edge	--	JUG(□□□□,Y,0)
	AG	Absolute angle 1 of circle and arc	--	JUG(□□□□,AG,0)
Pitch	N	Quantity	--	JUG(□□□□,N,0)
	W	Pitch (unit: pixels or degrees)	[△△]	JUG(□□□□,W,△△)
	WH	Maximum pitch (unit: pixels or degrees)	--	JUG(□□□□,WH,0)
	WL	Minimum pitch (unit: pixels or degrees)	--	JUG(□□□□,WL,0)
	WA	Average pitch (unit: pixels or degrees)	--	JUG(□□□□,WA,0)
Angle	AG	Angle (0° in the horizontal direction)	--	JUG(□□□□,AG,0)
Intensity	IA	Average brightness	--	JUG(□□□□,IA,0)
	ID	Standard brightness deviation	--	JUG(□□□□,ID,0)
	IH	Max brightness	--	JUG(□□□□,IH,0)
	IL	Minimum brightness	--	JUG(□□□□,IL,0)
Shape	N	Quantity	--	JUG(□□□□,N,0)
	X	X coordinates of found object	[△△]	JUG(□□□□,X,△△)
	Y	Y coordinates of found object	[△△]	JUG(□□□□,Y,△△)
	AG	Object angle found	[△△]	JUG(□□□□,AG,△△)
	S	Similarity	[△△]	JUG(□□□□,S,△△)
Pattern	N	Quantity	--	JUG(□□□□,N,0)

Comparison	X	X coordinates of found object	[ΔΔ]	JUG(□□□□,X,ΔΔ)
	Y	Y coordinates of found object	[ΔΔ]	JUG(□□□□,Y,ΔΔ)
	AG	Object angle found	[ΔΔ]	JUG(□□□□,AG,ΔΔ)
	S	Similarity	[ΔΔ]	JUG(□□□□,S,ΔΔ)
Blob	N	Quantity	--	JUG(□□□□,N,0)
	X	Center X coordinates	[ΔΔ]	JUG(□□□□,X,ΔΔ)
	Y	Center Y coordinates	[ΔΔ]	JUG(□□□□,Y,ΔΔ)
	AR	Blob area	[ΔΔ]	JUG(□□□□,AR,ΔΔ)
	PE	Circumference	[ΔΔ]	JUG(□□□□,PE,ΔΔ)
Stain	N	Cluster	--	JUG(□□□□,N,0)
	TAR	Total defective area	--	JUG(□□□□,TAR,0)
	AR	Defective area	[ΔΔ]	JUG(□□□□,AR,ΔΔ)
	X	Center X coordinates of all defects	[ΔΔ]	JUG(□□□□,X,ΔΔ)
	Y	Center Y coordinates of all defects	[ΔΔ]	JUG(□□□□,Y,ΔΔ)
Position Trace	XH	X coordinates of max outline	--	JUG(□□□□,XH,0)
	YH	Y coordinates of max outline	--	JUG(□□□□,YH,0)
	XL	X coordinates of min outline	--	JUG(□□□□,XL,0)
	YL	Y coordinates of min outline	--	JUG(□□□□,YL,0)
	RD	Roundness	--	JUG(□□□□,RD,0)
Width Trace	WH	Maximum width	--	JUG(□□□□,WH,0)
	WL	Minimum width	--	JUG(□□□□,WL,0)
	WA	Average width	--	JUG(□□□□,WA,0)
	RD1	Roundness 1 (inner)	--	JUG(□□□□,RD1,0)
	RD2	Roundness 2 (outer)	--	JUG(□□□□,RD2,0)

◎ The [Select Variable] Window

- The system provides 32 internal variable registers, REG(0)–REG(31). The registers store global variables, which are shared in all projects in the system.

Category	Variable List
Global Variable	Global Variable000
	Global Variable001
	Global Variable002
	Global Variable003
	Global Variable004
	Global Variable005

- You can also write and read temporary variable values through communication methods and use variable registers into calculator functions for relevant operations. For example, in the following diagram, a variable register is substituted into EQ (a function that compares whether two values are equal) as the comparative value.

W1003 Calculator

Cursor:

EQ(REG(0),REG(1))

6.3 What is an Output?

You can configure the content that is output to the superior PC or PLC through **Result Output**. The output can include each inspection result (including each numerical and logical result from **Inspection**, **Calculator**, and **Judge**). The system provides various interfaces to connect to the PC or controller, such as External I/O Terminal, RS232, RS485, Ethernet, and SD Card.

You can select the output interface and data independently. For example, when you enable RS232 for a PLC and Ethernet to a PC, you can output three data sets through RS232 and ten data sets through Ethernet. The system initiates data output for these two interfaces simultaneously after the inspection is complete.

6.3.1 Result Output Configurations

During the inspection process, click the icon on the **Result Output** box to enter the **Result Output** dialog box.

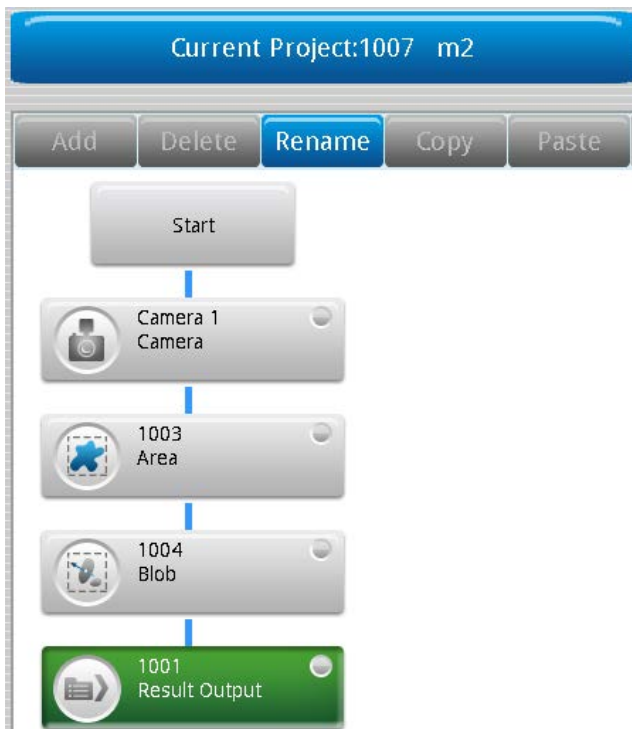

The following picture shows the **Result Output** dialog box.

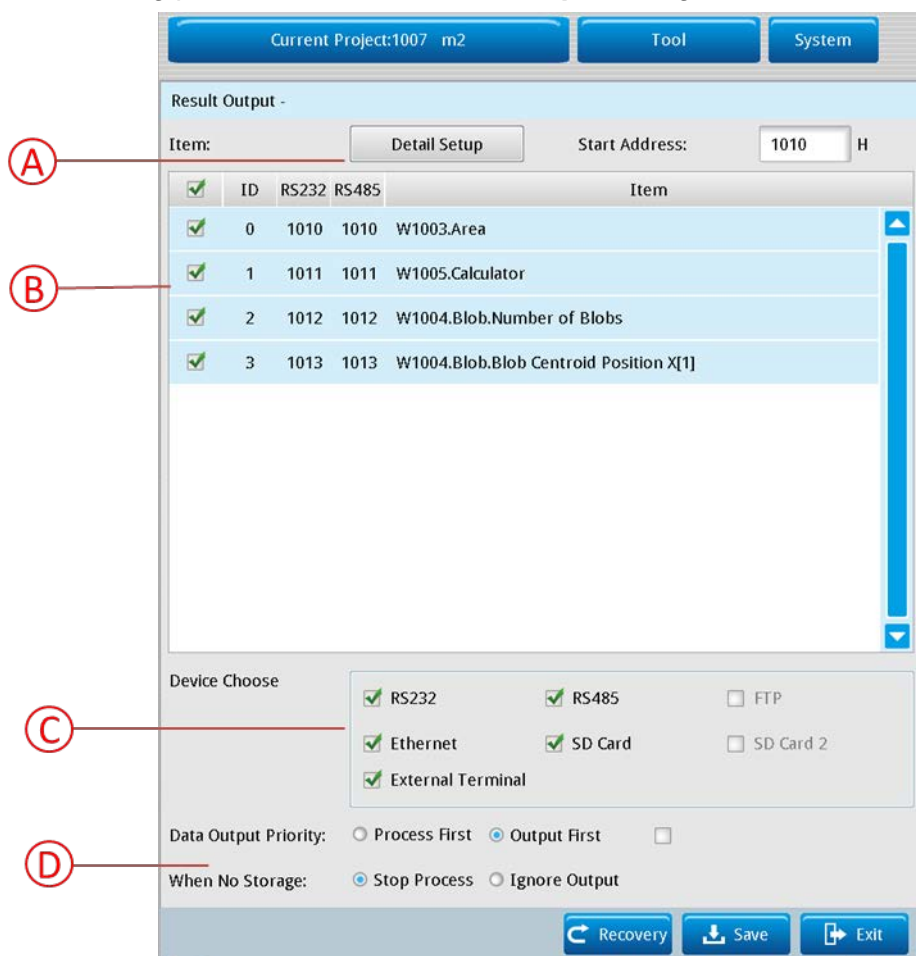

A. Detail Setup

Click **Detail Setup** to select the data for output. See **Detail Setup** below for details.

B. Output Item Display Area

Displays the data currently selected for output.

C. Device Choose

Select the hardware interface for the output.

You can select multiple output devices for simultaneous and independent output.

The external terminal uses I/O pins, and outputs data using a register consisting of OUT1–OUT16.

D. Other Relevant Configurations

1) **Data Output Priority**

Process First: When the inspection is complete but before data is fully transmitted, the system activates inspection and simultaneously completes transmitting the remaining data when TRIG triggers inspection signal input.

Output First: When inspection is complete but before data is fully transmitted, the system ignores the trigger command and completes transmitting the remaining data when TRIG triggers inspection signal input.

2) When No Storage

Stop Process: When data is output to the MicroSD memory card and the memory card is full, all subsequent trigger inspection are stopped.

Ignore Output: When data is output to the MicroSD memory card and the memory card is full, the system stops outputting data to the memory card but continues with inspections.

⊙ Detail Setup

Click **Detail Setting** to display the Select Item dialog box.

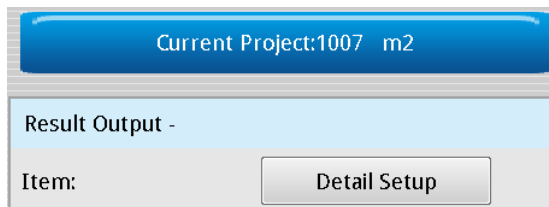

- When you select **Window** for **Choose Type** in the **Select Item** dialog box, the output is the logical (OK=1/NG=0) result of the Inspection. The logical OK/NG (Judge) result is generated according to the limits you set for the Inspection.

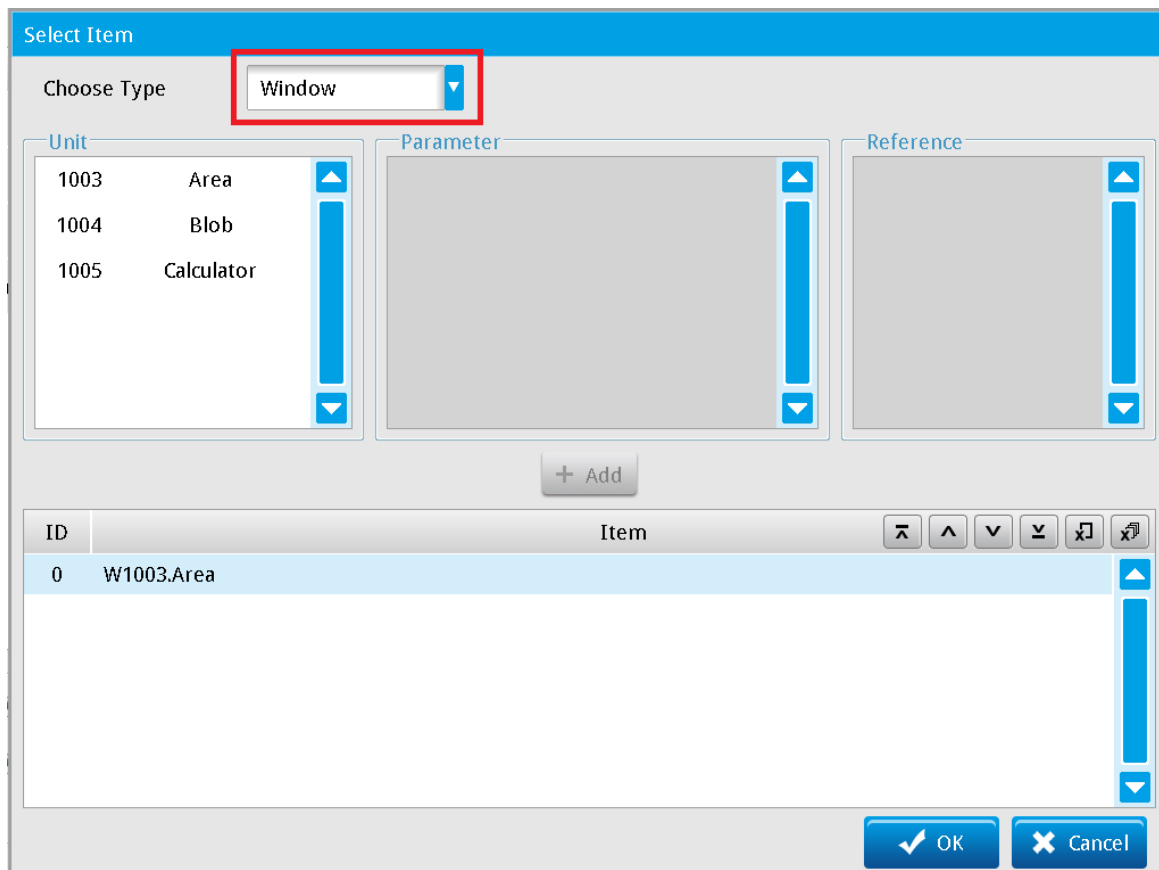

Chapter 6 Calculator, Result Output, and Status Item

Both Inspections and Calculators can generate OK/NG (Judge) results after you configure the upper and lower limits. The following example adds a Calculator result to the output. For **Choose Type**, select **Window**, then select the **Calculator** unit and then click **+Add** to add the calculator's OK/NG results to the output.

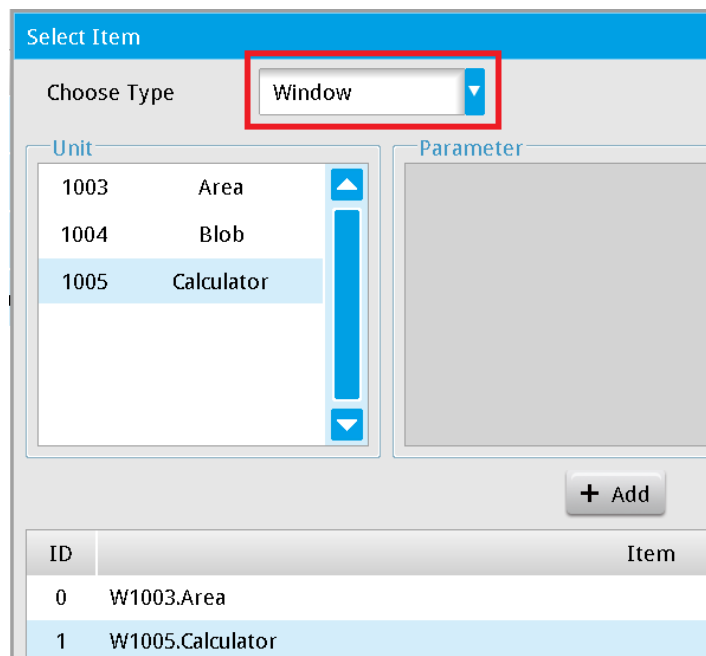

The order of result output is based on the top-to-bottom arrangement in the list. You can use the buttons above the Item list to rearrange the output items. Click an item in the list, and then click one of the buttons to move or delete the output item.

Move to top Move up one level Move down one level Move to bottom Delete

output Delete all output

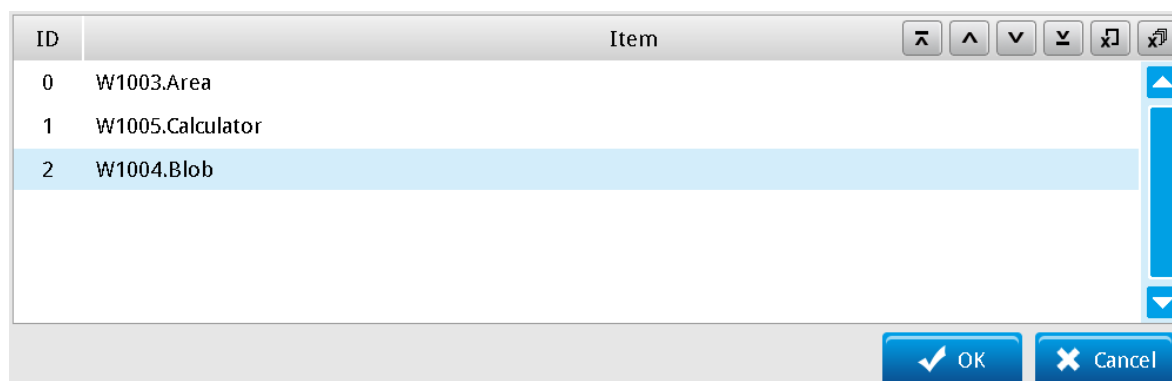

- When you select **Item** for **Choose Type**, the output result is the numerical result of the Inspection. As shown in the following picture, clicking **+Add** adds a Blob count inspection to the result items.

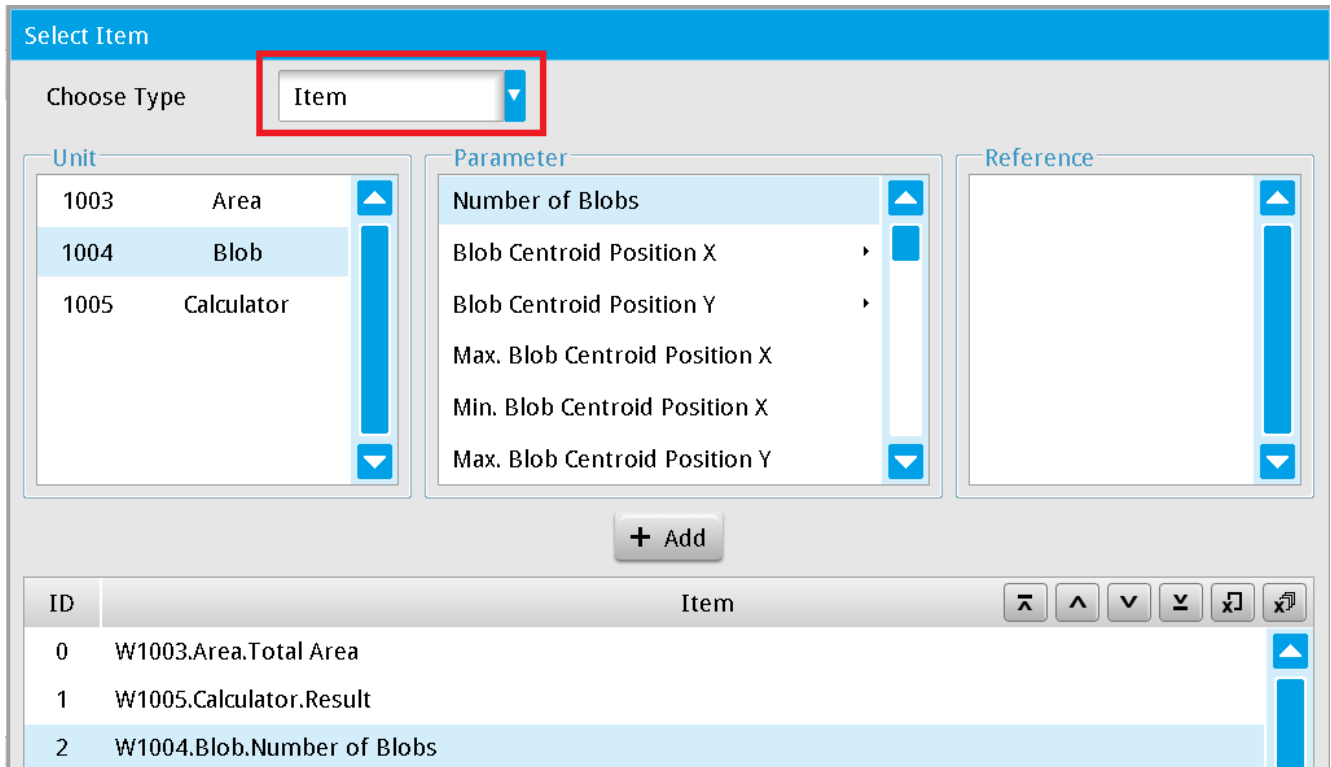

Some **Parameters** produce several inspection results, as shown in the following picture for **Blob Centroid Position X**. Therefore, you must select the desired result in the **Reference** column before you click **+Add**

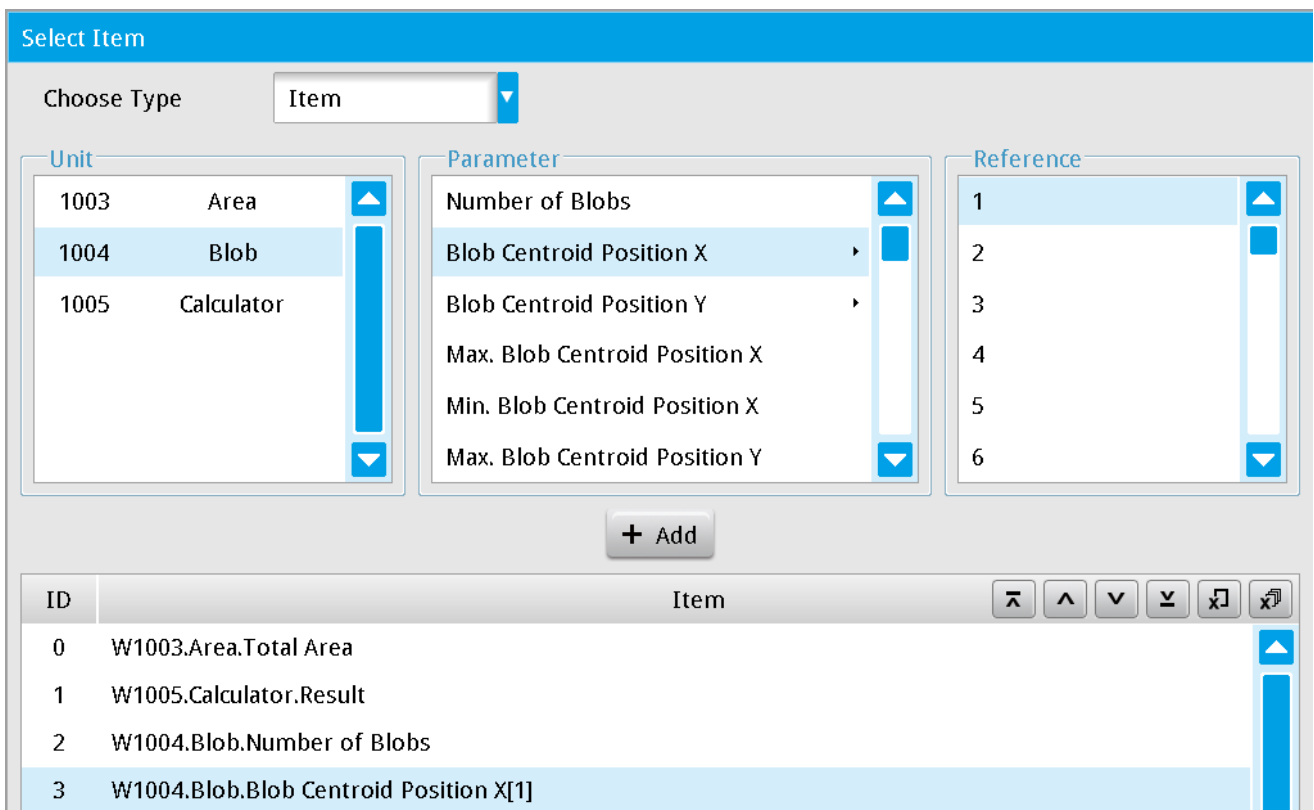

- After you create the output items in the Item list, you can choose which output items to output by

selecting the check box to the left side of the item (as shown in the following picture). Selected (checked) means include this item's results in the output.

When unchecked: do not include this item's results in the output.

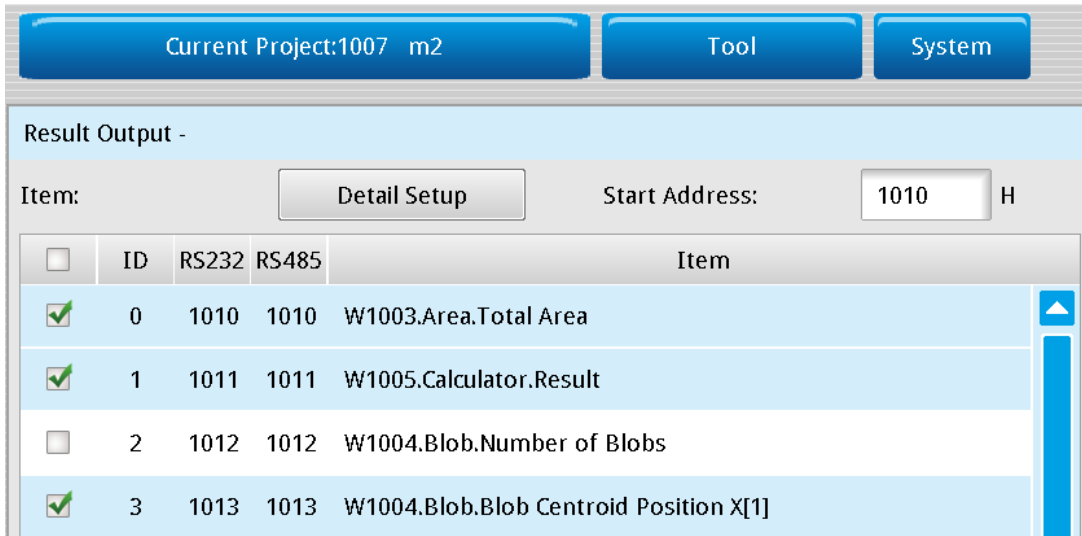

6.4 What is a Status Item?

Status Items let on-site operators observe the logical (OK/NG) and numerical inspection results. The status light displayed on the Run Mode screen enables the operator to choose the specific data to display in the status table.

6.4.1 Status Item Configurations

During the inspection process, click the icon on the **Status Item** box to display the **Status Item** dialog box.

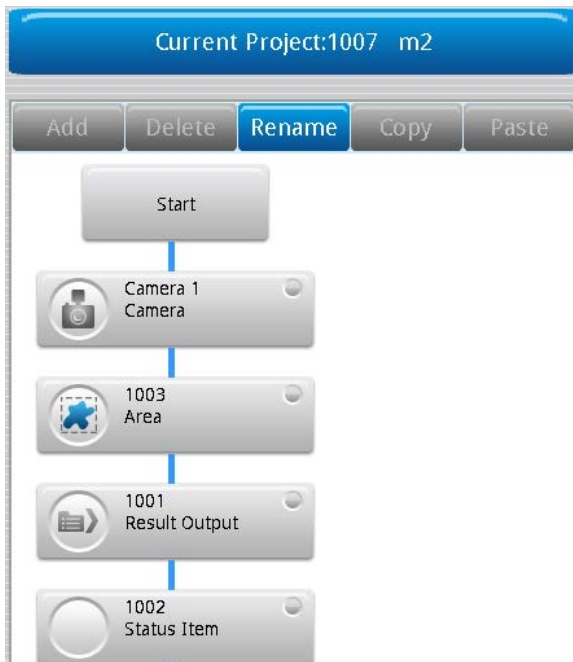

⊙ **Detail Setup**

In the **Status Item** dialog box, click **Detail setting** to display the **Select Item** dialog box.

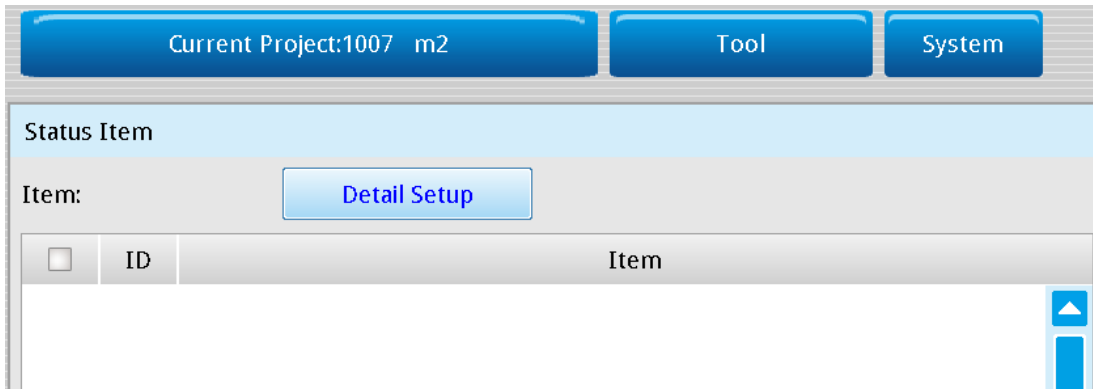

- When you select **Window** for the **Choose Type**, the output is the logical (OK=1/NG=0) result of the Inspection. The logical OK/NG (Judge) result is generated according to the limits that you configure for the Inspection.

Next, click **+Add** to add the selected Unit to the to the **Item** list. The following picture shows the Item list after selecting Area and clicking **+Add**.

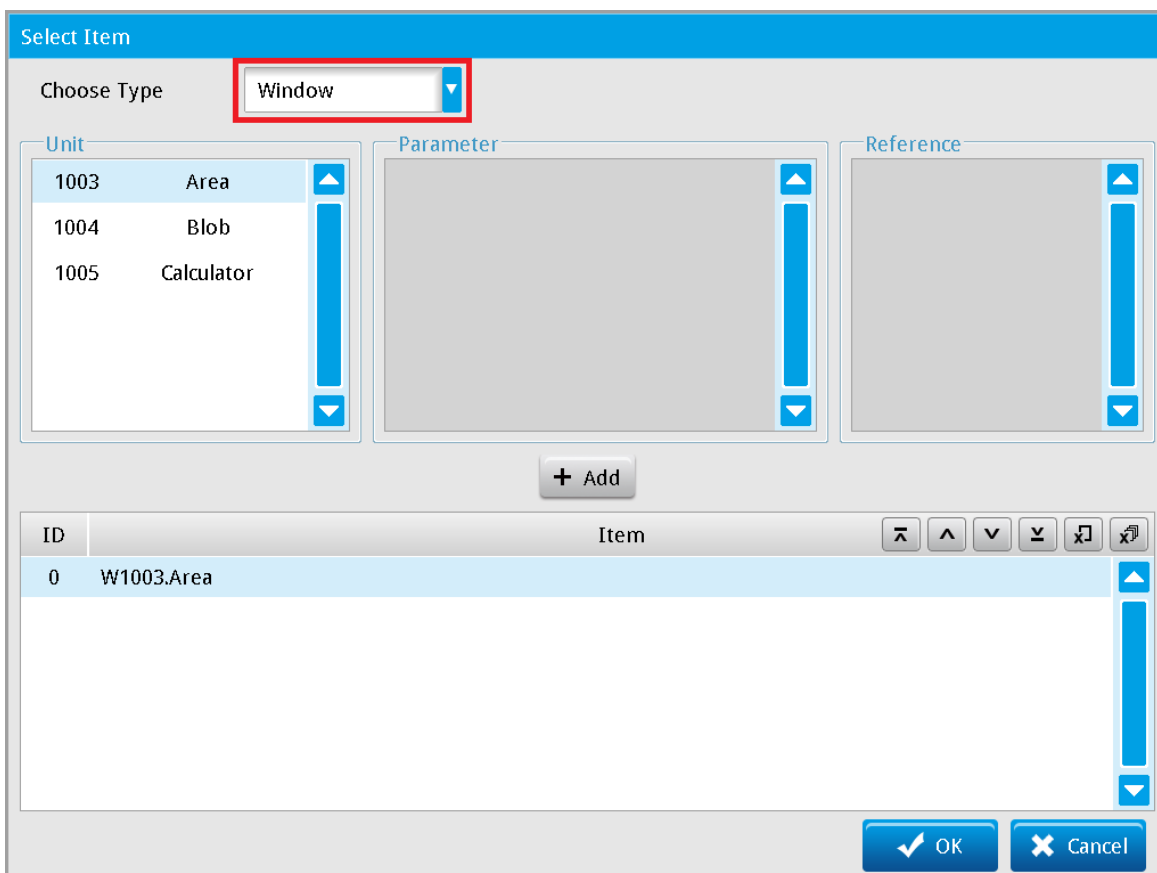





Chapter 6 Calculator, Result Output, and Status Item

Both Inspections and Calculators can generate OK/NG (Judge) results after you configure the upper and lower limits. The following example adds a Calculator result to the output.





For **Choose Type**, select **Window**. Select the **Calculator** unit and then click **+Add** to add the calculator's OK/NG results to the output.

ID	Item
0	W1003.Area
1	W1005.Calculator

The order of result output is based on the top-to-bottom arrangement in the list. You can use the buttons above the Item list to rearrange the output items. Click an item in the list, and then click one of the buttons to move or delete the output item.

 Move to top  Move up one level  Move down one level  Move to bottom  Delete

output  Delete all output

ID	Item					
0	W1003.Area					
1	W1005.Calculator					
2	W1004.Blob.Number of Blobs					

- When you select **Item** for **Choose Type**, the output result is the numerical result of the Inspection. As shows in the following picture, clicking **+Add** adds a blob count inspection to the result items.

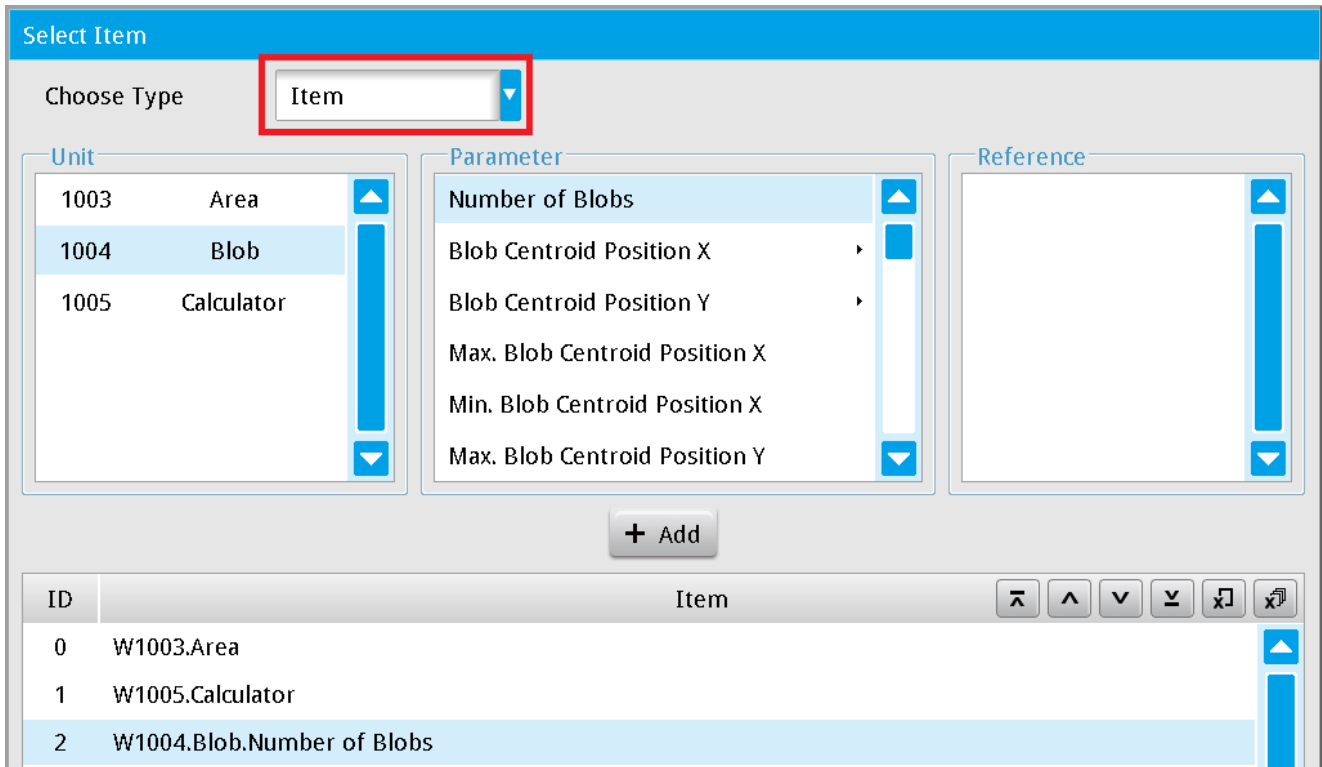

Some **Parameters** produce several inspection results, as shown in the following picture for **Blob Centroid Position X**. Therefore, you must select the desired result in the **Reference** column before you click **+Add**.

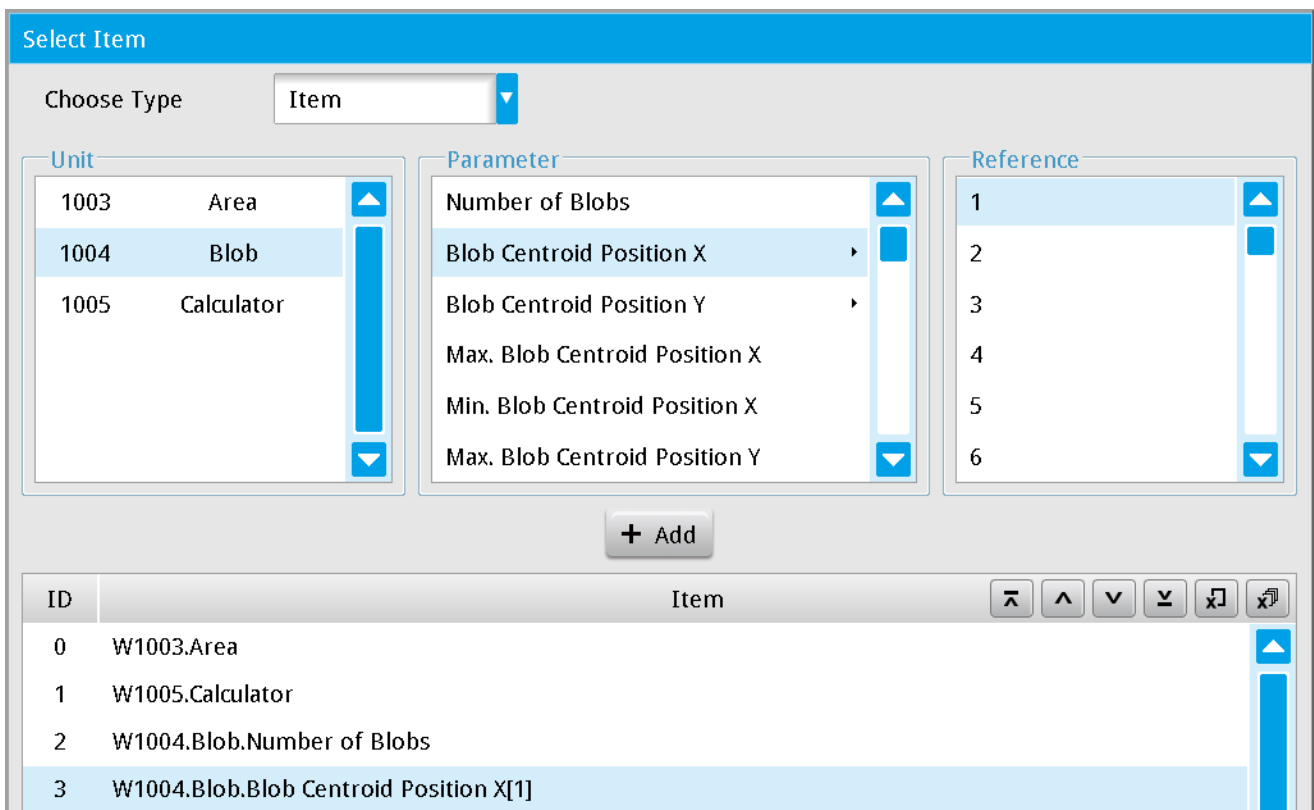

- After you create the Status Light items in the **Item** list, you can choose which items to display by selecting the check box to the left side of the item (as shown in the following picture).
Selected (checked): the light signal displays for the item on the Run Mode screen.
Cleared (unchecked): the light signal is not displayed for the item.

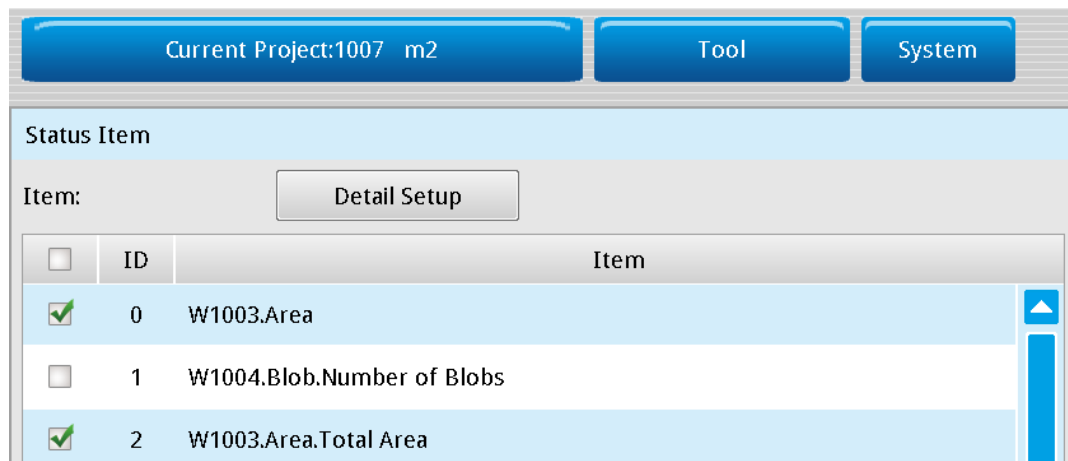

After completing the above configurations and switching to RUN mode, the **Image Display Window** appears in the Run Mode screen. Select the **LED menu** check box at the bottom (as shown in the picture below on the left) to open the **Item LED** data table that shows the user defined result items (as shown in the picture below on the right).

Item				
OK	Item	Lower	Value	Upper
<input checked="" type="checkbox"/>	W1003.Area	---	1.000	---
<input checked="" type="checkbox"/>	W1003.Area.Total Area	0.000	2312920.000	4194304.000
<input type="checkbox"/>	None	---	---	---
<input type="checkbox"/>	None	---	---	---
<input type="checkbox"/>	None	---	---	---

Page: 1 / 26

Chapter 7

Input and Output I/O Terminal

The I/O interface provides the main communication method between the DMV2000 and the superior controller and features the following functions.

- ◎ **Current system state indicator**
For example: Ready, Run, Error and so on
- ◎ **Camera imaging trigger capture**
You can also issue this trigger issued through the RS232 or Ethernet ports; however the I/O channel is more responsive than the communication channels.
- ◎ **Flash output**
The system parameters coordinate the light flash output with the camera shutter action (must use with the light controller).
- ◎ **Project switching**
Multiple I/O signals to switch projects. You can also issue this trigger through the RS232 or Ethernet ports.

◎ **Output results**

After each inspection, the DMV2000 can transmit the logical OK(1) / NG(0) and numerical results through the I/O channel. These values can also be transmitted through the RS232 or Ethernet ports. In general, if the output consists of only OK(1) / NG(0) data, the I/O channel is more responsive and the string does not need to be processed.

◎ **I/O Contact**

The 8-point input and 11-point output removable I/O terminals are provided on the left side of the system (shown in the following diagram).

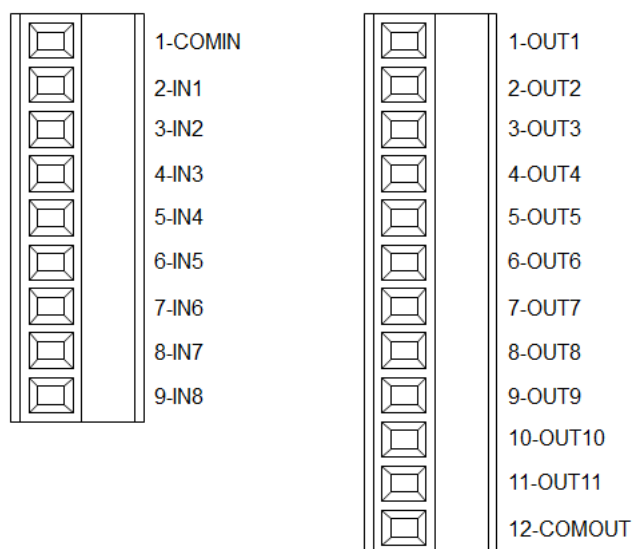

7.1 Definition of the I/O Functions

Depending on the model, the DMV2000 can support up to eight cameras and execute eight parallel processes. Therefore, 8 TRIG signals are provided.

You can define the function of each I/O point. During operation, on the Main window, click **Communication Settings > External Communication Device Setting > External Terminal** to view the I/O configuration table.

Device Setting

External Terminal

Ethernet

RS232

RS485

Signal Test Mode: Enable Disable Restore Default Setting

Enable	Terminal	Signal Phase Setting	Signal	Test Signal
<input checked="" type="checkbox"/>	IN1	None	TRIG1	Input <input type="radio"/>
<input checked="" type="checkbox"/>	IN2	None	TRIG2	Input <input type="radio"/>
<input type="checkbox"/>	IN3	None	TRIG3	Disable <input type="radio"/>
<input type="checkbox"/>	IN4	None	TRIG4	Disable <input type="radio"/>
<input type="checkbox"/>	IN5	None	TEST	Disable <input type="radio"/>
<input type="checkbox"/>	IN6	None	PLINK	Disable <input type="radio"/>
<input type="checkbox"/>	IN7	None	TROFF	Disable <input type="radio"/>
<input type="checkbox"/>	IN8	None	ACK	Disable <input type="radio"/>

Enable	Terminal	Signal Phase Setting	Signal	Test Signal
<input type="checkbox"/>	OUT1	Normal Output	RDY	Disable <input type="radio"/>
<input type="checkbox"/>	OUT2	Normal Output	TOUT1	Disable <input type="radio"/>
<input type="checkbox"/>	OUT3	Normal Output	TOUT2	Disable <input type="radio"/>

OK Cancel

Reference The definition of functions for each I/O terminal is explained in Section 2.1.3.

① Enable Input Terminal

Select the check box next to the terminal to enable the terminal.

Enable	Terminal	Signal Phase Setting	Signal
<input checked="" type="checkbox"/>	IN1	None	TRIG1
<input type="checkbox"/>	IN2	None	TRIG2
<input type="checkbox"/>	IN3	None	TRIG3

◎ Change Input Function

Select the input signal from the **Signal** list.

Enable	Terminal	Signal Phase Setting	Signal
<input checked="" type="checkbox"/>	IN1	None	TRIG1
<input type="checkbox"/>	IN2	None	NONE
<input type="checkbox"/>	IN3	None	TRIG1
<input type="checkbox"/>	IN4	None	TRIG2

◎ Enable Output Terminal and Change Output Function

Select the check box next to the terminal to enable the terminal, and select the output function from the **Signal** list.

<input type="checkbox"/>	IN5	None	TEST
<input type="checkbox"/>	IN6	None	NONE
<input type="checkbox"/>	IN7	None	RDY
<input type="checkbox"/>	IN8	None	TOUT1
			TOUT2
			ERR
Enable	Terminal	Signal Phase Setting	Signal
<input checked="" type="checkbox"/>	OUT1	Normal Output	RDY



◎ Inverse Output

Output signals include NC (normally closed) and NO (normally open) options. The output signal is NO when you select **Inverse Output** (contacts remains ON when the output is not active).

<input type="checkbox"/>	IN5	Normal Output	TEST
<input type="checkbox"/>	IN6	Inverse Output	PLINK
<input type="checkbox"/>	IN7		TROFF
<input type="checkbox"/>	IN8		ACK
Enable	Terminal	Signal Phase Setting	Signal
<input checked="" type="checkbox"/>	OUT1	Inverse Output	RDY

◎ **Advanced Settings for TOUT1–TOUT4**

The system provides four independent output signals (TOUT1–TOUT4) that you can configure. Use TOUT1–TOUT4 to signal the total result output according to the varying superior controller requirements. There are various output methods for configuration and adjustments. Click the square button to the right of the **Signal** column to configure TOUT in the **Protocol Setting** dialog box.

Enable	Terminal	Signal Phase Setting	Signal
<input type="checkbox"/>	OUT1	Inverse Output ▼	RDY ▼
<input type="checkbox"/>	OUT2	Normal Output ▼	TOUT1 ▼ 
<input type="checkbox"/>	OUT3	Normal Output ▼	TOUT2 ▼ 

Protocol Setting

TOUT

TOUT 1 2 3 4

TOUT1 Pulse Width: ms

TOUT1 Output Timing: When OK Output When NG Output

TOUT1 Output Type: Pulse Signal Hold Signal

➤ **TOUT1 Pulse Width**

Specifies the output pulse width when you select **Pulse Signal** for **Output Type**

➤ **TOUT1 Output Timing**

Specifies whether to output when total result is OK or NG

➤ **TOUT1 Output Type**

When you select **Pulse Signal**, the system uses the **TOUT1 Pulse Width** for the output pulse width. When you select **Hold Signal**, the output signal only changes after the completion of the next Inspection.

➤ You configure **TOUT2-TOUT4** in the same way as TOUT1

7.2 I/O Activation Timing

7.2.1 TRIG (Trigger) Capture

- ▶ Depending on the model, the DMV2000 can support up to 8 cameras, and provides up to eight TRIG trigger signals (TRIG1–TRIG8).
- ▶ Each camera can independently be paired with a TRIG trigger signal; for example, pair Camera1 with TRIG1, Camera2 with TRIG2.
- ▶ Multiple cameras can share the same TRIG trigger signal; for example, Camera1 and Camera2 can both use TRIG1.

◎ Use Single Flow Process

One camera coupled with one TRIG trigger signal

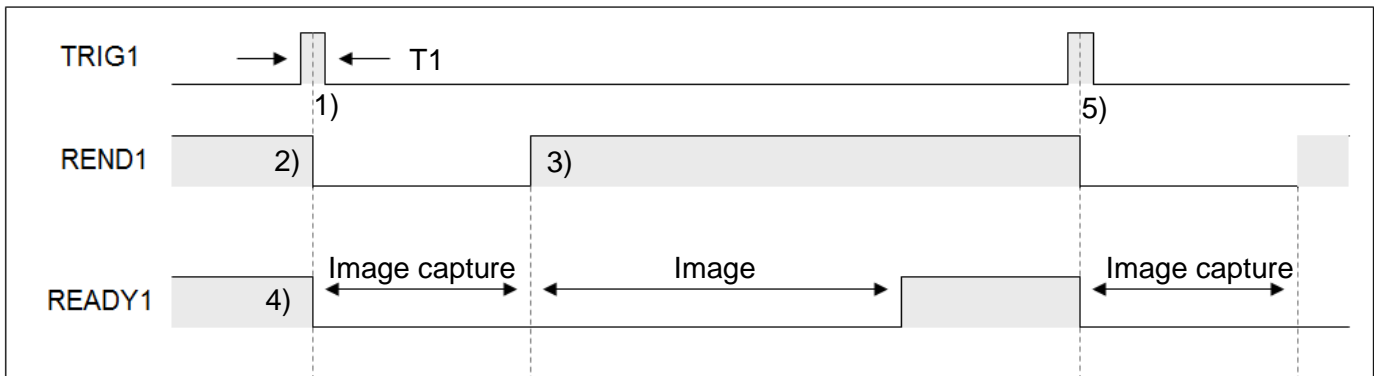

Description:

- 1) Trigger period T1 must be longer than 1ms. If T1 is too short, the trigger may not respond.
- 2) REND1 signal switches OFF after trigger.
- 3) When the image is captured (exposure and capture + image transfer), REND1 signal switches ON.
- 4) READY1 signal switches OFF after capture and switches ON after completing the inspection (image capture + image processing).
- 5) Steps 1–4 are a complete inspection cycle and the system is ready for the next trigger signal.

Use the READY1 signal as the logical (Judge) condition for the TRIG1 trigger timing.

Total period = image capture time + image processing time

◎ **Use Single Flow Process**

Two cameras coupled with one TRIG trigger signal: Camera1 and Camera2 are both configured as coupled with TRIG1 trigger.

- TRIG1 initiates the system to automatically capture Image1 and Image2.

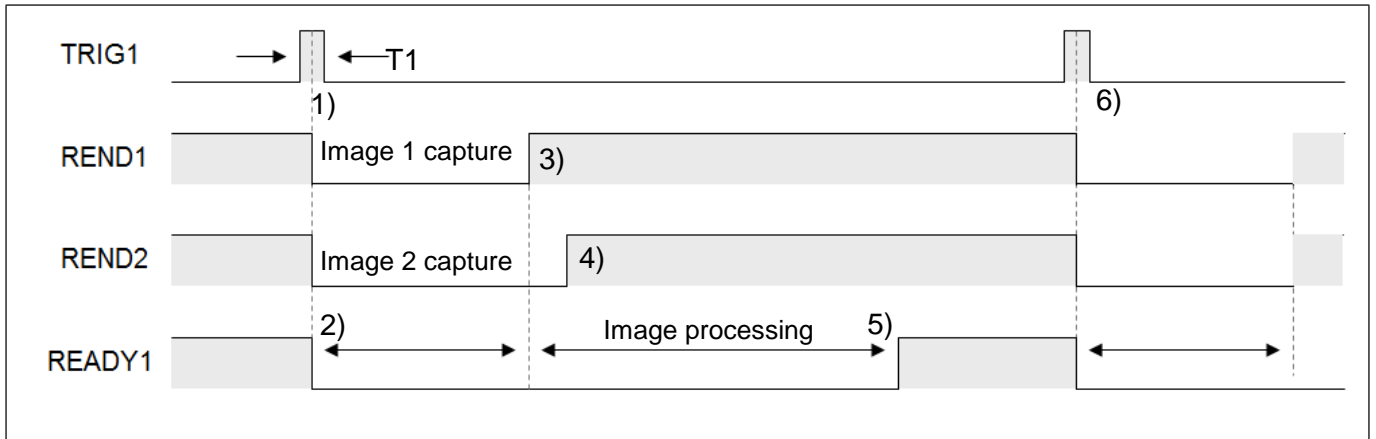

Description:

- 1) Trigger period T1 must be longer than 1ms. If T1 is too short, the trigger may not respond.
- 2) After Trigger1 is initiated, READY1 and camera REND1 and REND2 switch OFF.
- 3) REND1 is ON after Image1 is captured.
- 4) REND2 is ON after Image2 is captured.
- 5) READY1 is ON after image processing is complete.
- 6) Steps 1–5 are a complete inspection cycle and the system is ready for the next trigger signal.

Use the READY1 signal as the logical (Judge) condition for the TRIG1 trigger timing.

Total cycle time = (Image1 capture time + Image2 capture time) + image processing time

© Multiplexing Flow Process (Asynchronous Flow)

Two cameras coupled with two TRIG trigger signals.

- Camera1 is coupled with TRIG1, Camera2 is coupled with TRIG2, and the trigger order of TRIG1 and TRIG2 is unrestricted.

Each flow process generates independent outputs, immediately after completing each trigger inspection. The outputs are irrelevant to the TRIG signals for other flow processes.

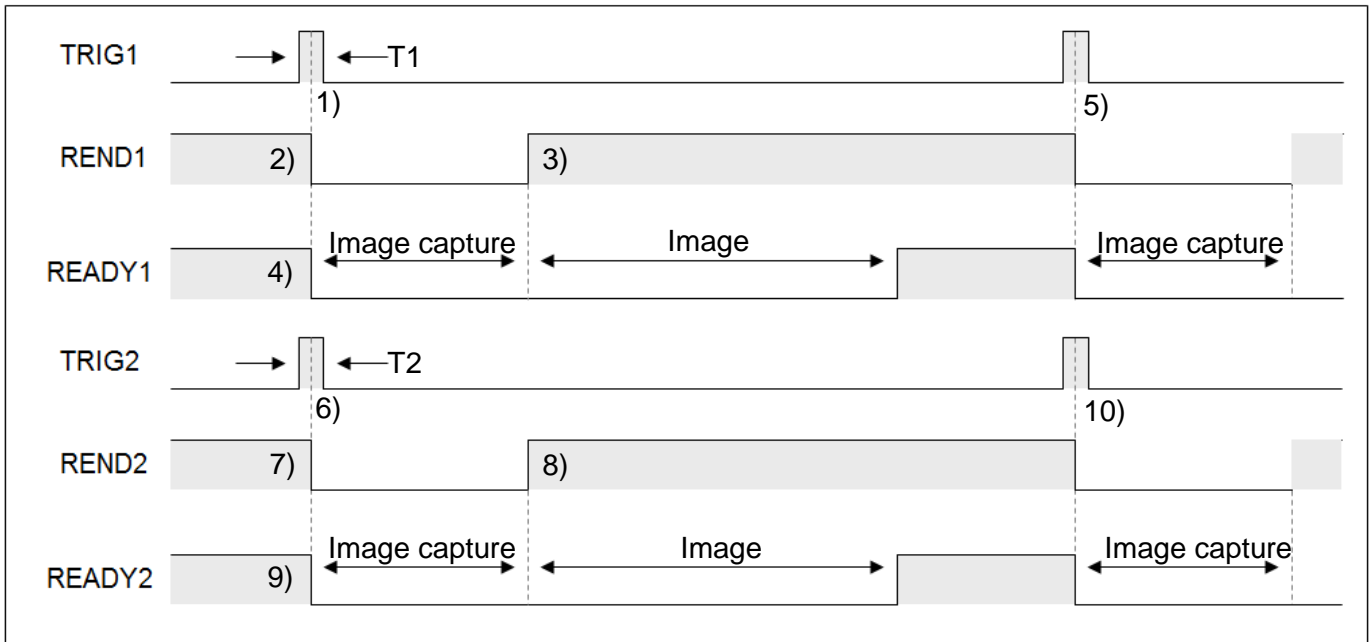

Description:

- 1) Trigger period $T1$ must be longer than 1ms. If $T1$ is too short, the trigger may not respond.
- 2) REND1 signal switches OFF after trigger TRIG1.
- 3) When the image is captured (exposure and capture + image transfer), REND1 signal switches ON.
- 4) READY1 signal switches OFF after capture and switches ON after completing the inspection (image capture + image processing).
- 5) Steps 1–4 are a complete an inspection cycle and the system is ready for the next trigger signal.
- 6) Trigger period $T2$ must be longer than 1 ms. If $T2$ is too short, the trigger may not respond.
- 7) REND2 signal switches OFF after trigger.
- 8) When the image is captured (exposure and capture + image transfer), REND2 signal switches ON.
- 9) READY2 signal switches OFF after capture and switches ON after completing the inspection (image capture + image processing).
- 10) Steps 6–9 are a complete inspection cycle and the system is ready for the next trigger signal.

Use the READY signal as the logical (Judge) condition for TRIG trigger timing.

Total period = image capture time + image processing time

7.2.2 Flash Timing

Proper timing of the light source is crucial to the quality of the captured image. The system supports FLASH1–FLASH4 outputs to control the output timing of peripheral light sources.

Remark The light controller for the light source must have an external trigger input function when using the FLASH signal.

- The output of flash activation signal must occur before the activation of camera shutter.

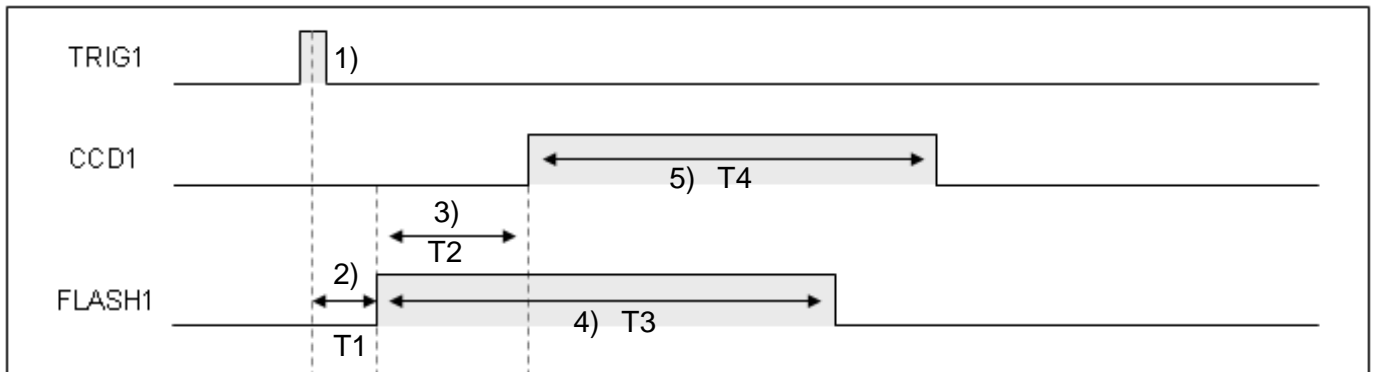

T1: Delay by approximately 1 ms (reaction times vary according to differing lights).

T2: Configured in Output Start Time (Unit: 0.1 ms)

T3: Configured in During Time (Unit: 0.1 ms)

T4: Configured in Shutter Time for the camera

Description:

- 1) When TRIG is triggered, timed flash output is enabled.
- 2) Due to processing delays of the light, the flash output is delayed by approximately 1 ms.
- 3) The flash output occurs before the camera shutter; therefore, the activation of camera shutter is delayed.
- 4) Total time of flash output.
- 5) Shutter duration of the camera.

Remark The CCD1 (2) signal is controlled internally in the system, unlike typical external terminals. Therefore, external pins are not provided for CCD1 (2).

The following picture shows the **Flash1** setup in the **Camera 1** dialog box when the flash output is before the shutter output.

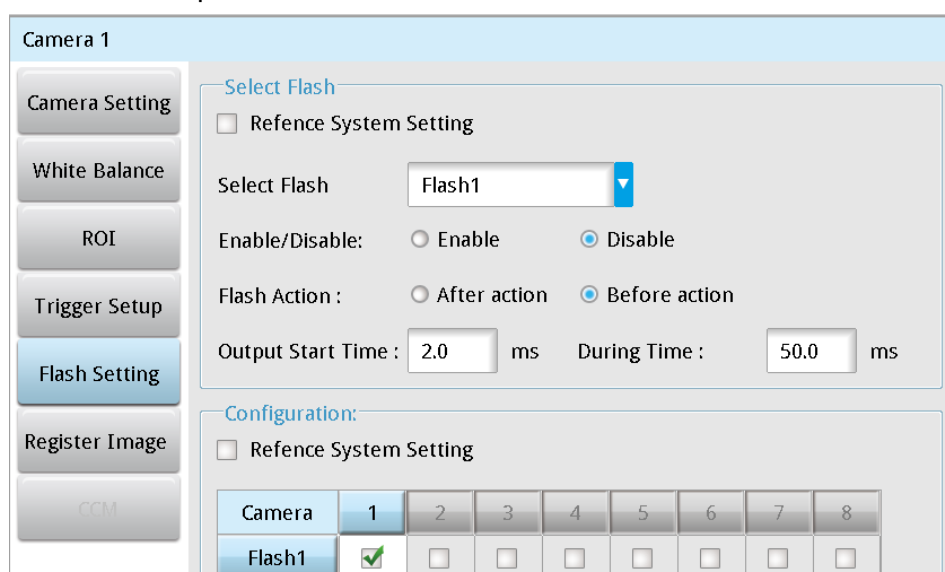

- The output of flash activation signal occurs after the activation of camera shutter.

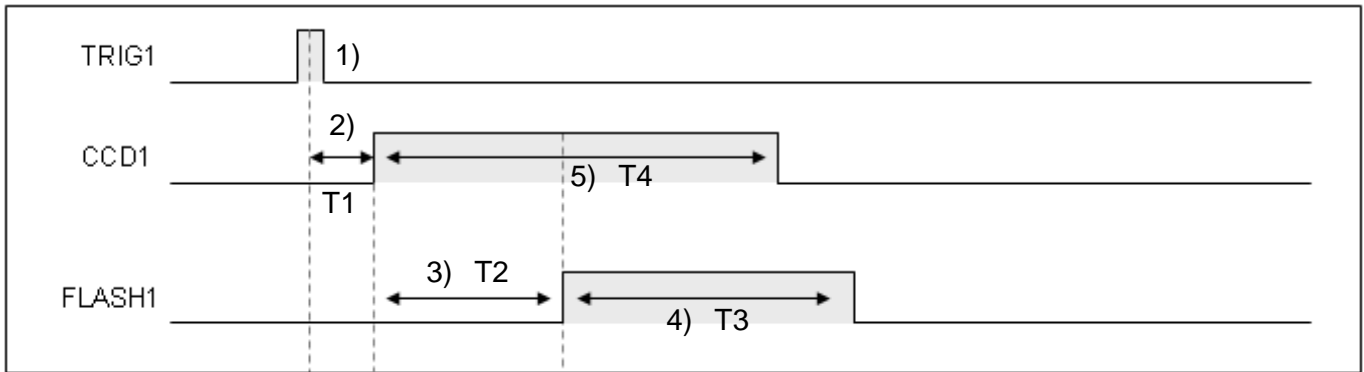

- T1: Delay by approximately 1 ms
- T2: Configured in Output Start Time (Unit: μs)
- T3: Configured in During Time (Unit: 100 μs)
- T4: Configured in Shutter Time for the camera

Description:

- 1) When TRIG is triggered, timed flash output is enabled.
- 2) Due to processing delays of the light, the flash output is delayed by approximately 1 ms.
- 3) The flash output occurs after the camera shutter; therefore, the flash output activation is delayed.
- 4) Total time of flash output.
- 5) Shutter duration of the camera.

If the flash duration time is greater than (shutter duration + frame refresh time + internal processing time), the flash always remains ON. The following picture shows the **Flash1** setup in the **Camera 1** dialog box when the flash output is after the shutter output.

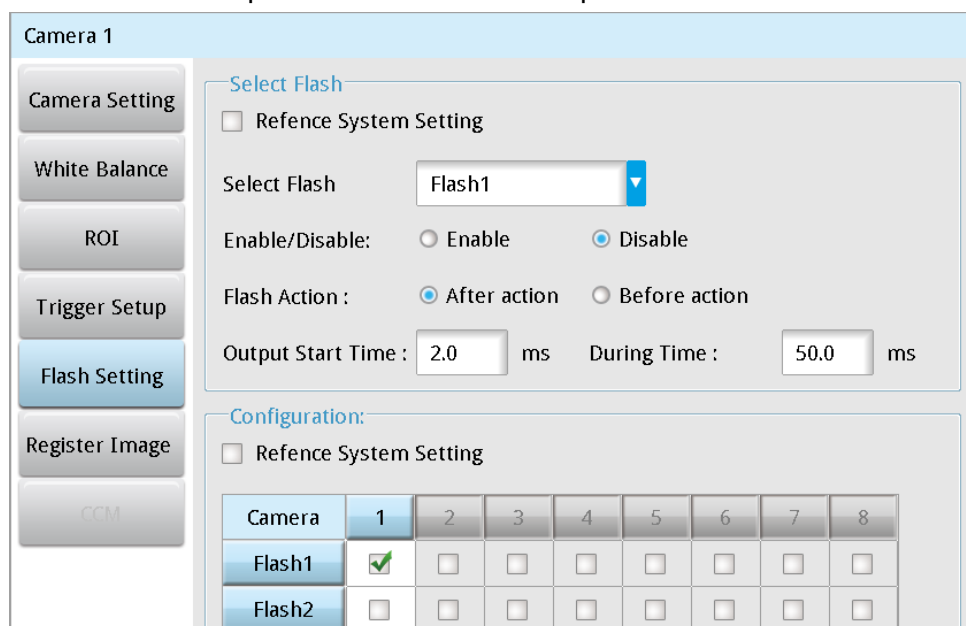

7.2.3 External Terminal Result Output

The DMV2000 system supports parallel I/O, RS232, USB, Ethernet, PLC Link, and SD card output methods. The communication interface may consist of a combination of different channels based on the controller hardware or speed requirements.

➤ Parallel I/O Output: (Output Delay)

When using external I/O terminal for output, then you can configure the **Data Output Delay Time**.

Refer to the diagram below. If you set delay to 10 ms, the system delays 10 ms before activating the external terminal for I/O output after completing the inspection.

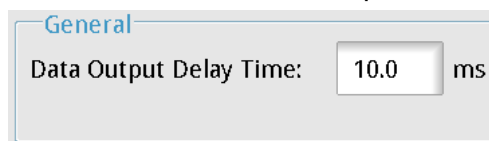

➤ Parallel I/O Output: (No Handshake)

Only applicable in Single Process projects when transmitting resulting values using the I/O.

In addition to the total output (TOUT), there are 16 output points for status indicators or numerical output.

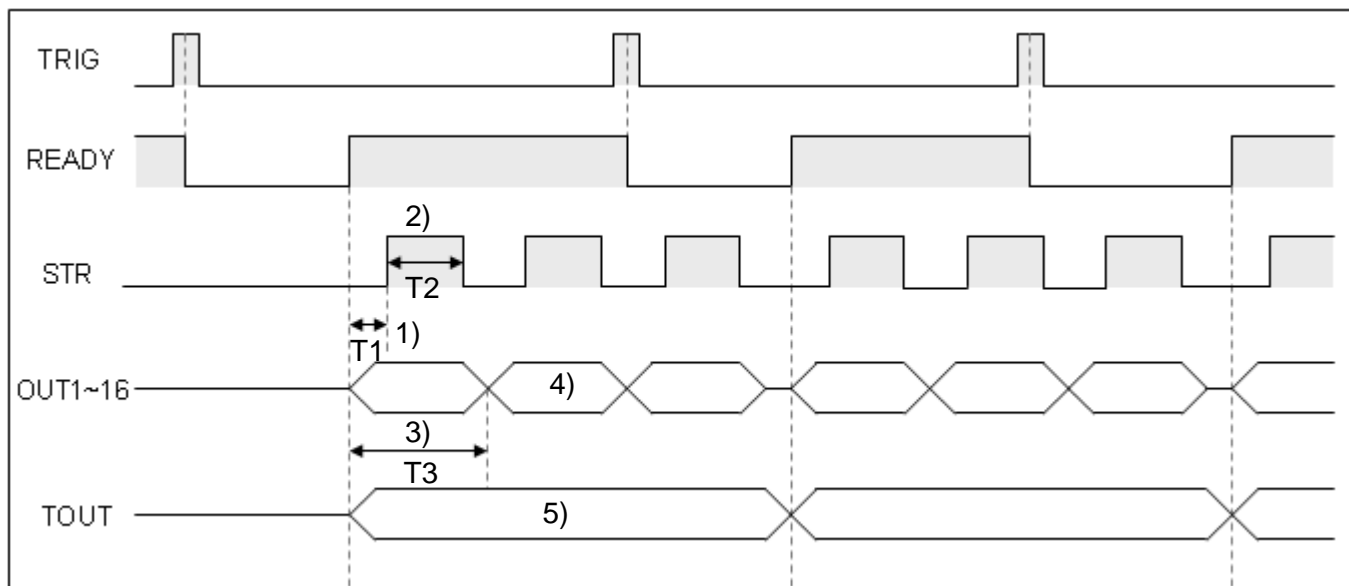

T1: Configure in STR Start Delay (Unit: ms)

T2: Configure in STR Output Time (Unit: ms)

T3: Configure in Data Output Time (Unit: ms)

Description:

- 1) When READY is ON, the delay begins for STR; STR is output after the delay.
- 2) You can configure the STR output cycle. Set an output time that allows the superior controller to read the value..
- 3) The OUT1–16 output cycle configurations must satisfy the requirement of (Data Output Time \geq STR Start Delay + STR Output Time).

The following picture shows the **Protocol Setting** dialog box where you set the STR timing. From the Main window, click **System > Communication Setting > External Signal Device Setting > STR Output Function**.

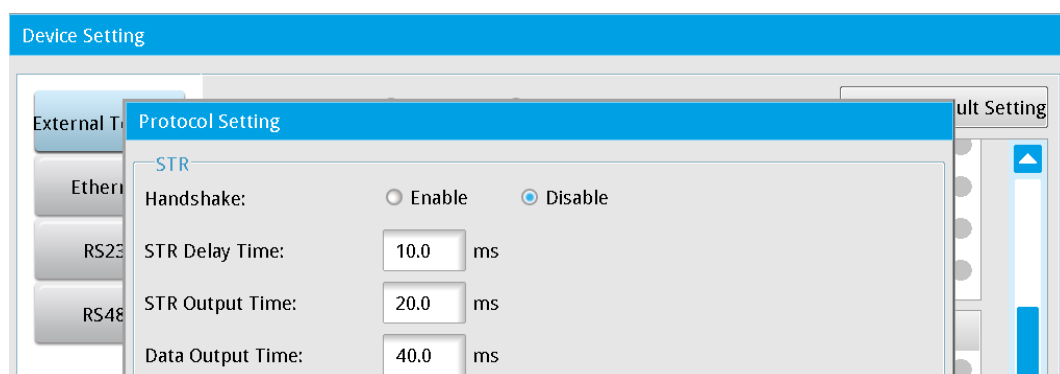

► Parallel I/O Output: (Handshake Control)

This is applicable only in Single Process projects when transmitting the result values using the I/O.

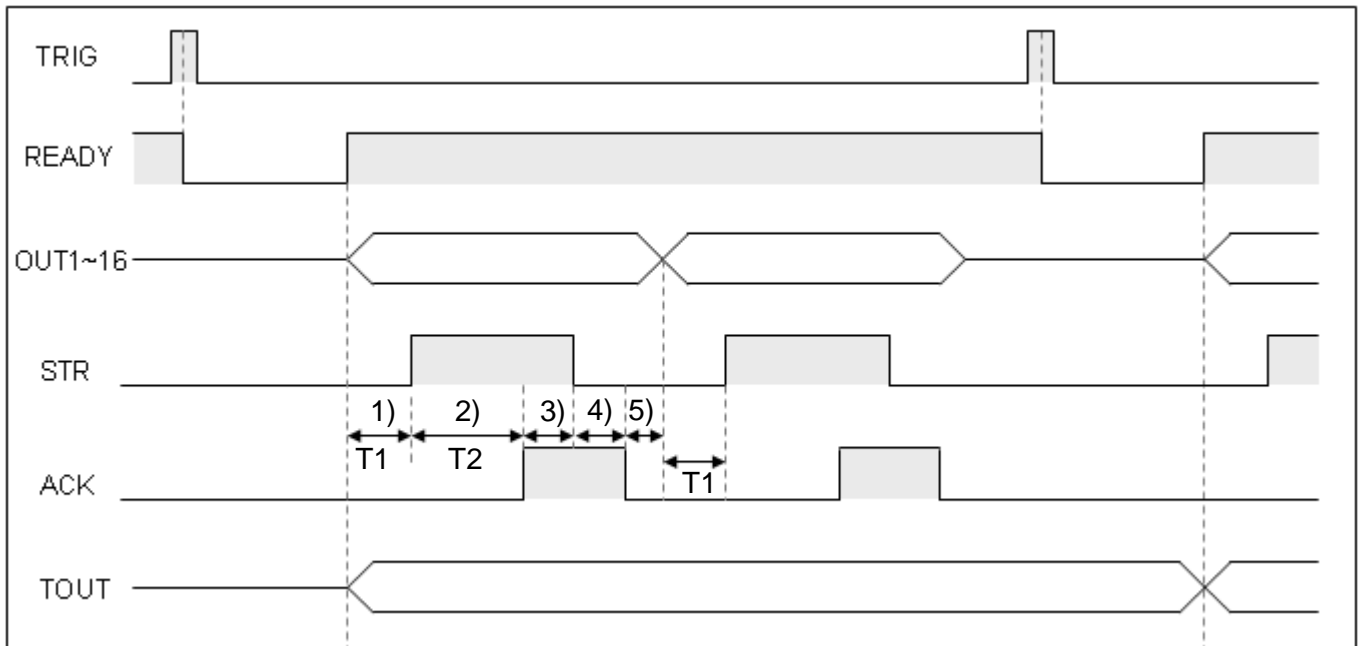

T1: Configure in STR Start Delay (Unit: ms)

T2: Configure in Communication Timeout (Unit: ms)

Description:

- 1) When READY is ON, the delay begins for STR; STR is output after the delay.
- 2) STR outputs and waits for the input of the handshake signal ACK. The output is interrupted if no response is detected within the Communication Timeout. Also, the ERROR signal is sent and the ERROR indicator light is ON.
- 3) After STR is sent, the switch turns OFF after the ACK signal is detected.
- 4) After STR switches OFF, the ACK signal must also be turned OFF to enable the next data output.
- 5) After ACK is off, the next batch of data is output.

► Parallel I/O Output: (8/16/32/64-bit output data formats)

Only applicable in Single Process projects when transmitting resulting values using the I/O.

In the OUTPUT options, **Output Num. Pins** can be either 8 Pins or 16 Pins. **Data Format** includes the options of 8 Bits/16 Bits/32 Bits/64 Bits. Various pin numbers and data formats can be paired to generate different outputs.

- 1) 8 Pins paired with 8 Bits: the system outputs data in 8 bits through OUT1–OUT7 in one transmission. Two 16-bit output data entries are divided into four transmissions.
- 2) 16 Pins paired with 16 Bits: the system outputs data outputs in 16 bits through OUT0–OUT15 in one transmission. Two 16-bit output data entries are divided into two transmissions.
- 3) 16 Pins paired with 32 Bits: the system outputs data outputs in 16 bits through OUT0–OUT15 in one transmission. Two 32-bit output data entries are divided into four transmissions.
- 4) 16 Pins paired with 64 Bits: the system outputs data outputs in 16 bits through OUT0–OUT15 in one transmission. One 64-bit output data entry is divided into four transmissions.

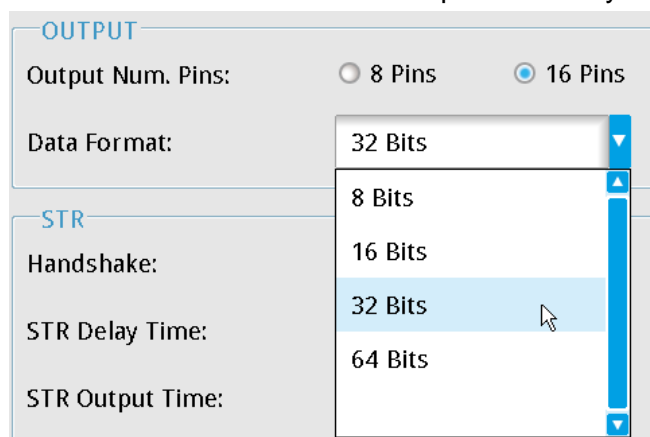

An example is shown in the following diagram. When using 32-bit output format, each data entry is divided into two parts for transmission.

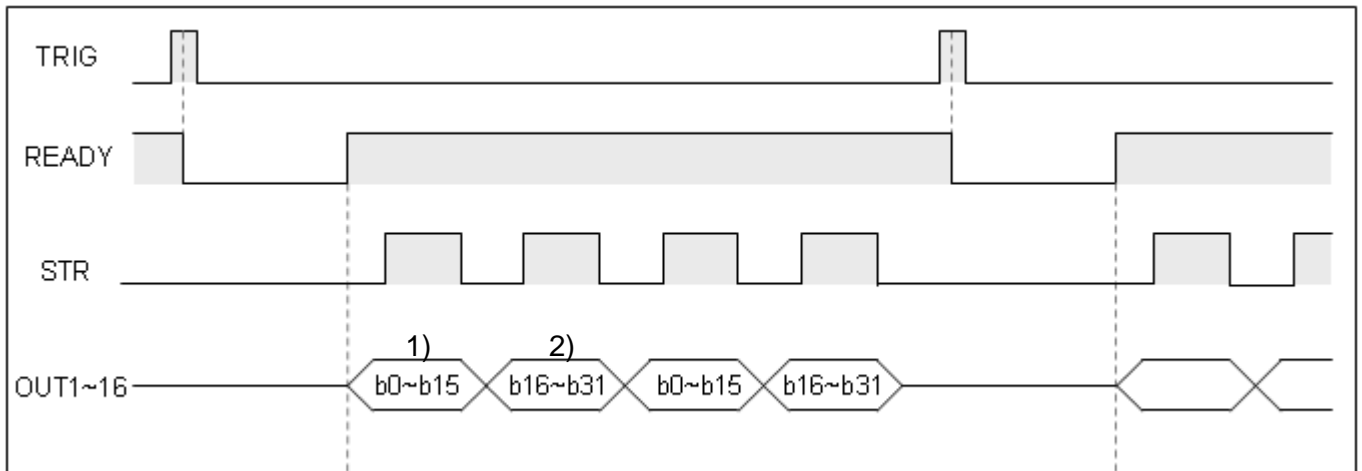

Description:

- 1) Leading 16 bits of the 32-bit data.
- 2) Trailing 16 bits of the 32-bit data.

Remark 16-bit data range: signed binary (-32768 to 32767), unsigned binary (0-65535). 32-bit data range: -2147483648 to 2147483647

7.2.4 Communication Result Output

- RS232, USB, ETHERNET, memory card, PLC-Link, and image storage output

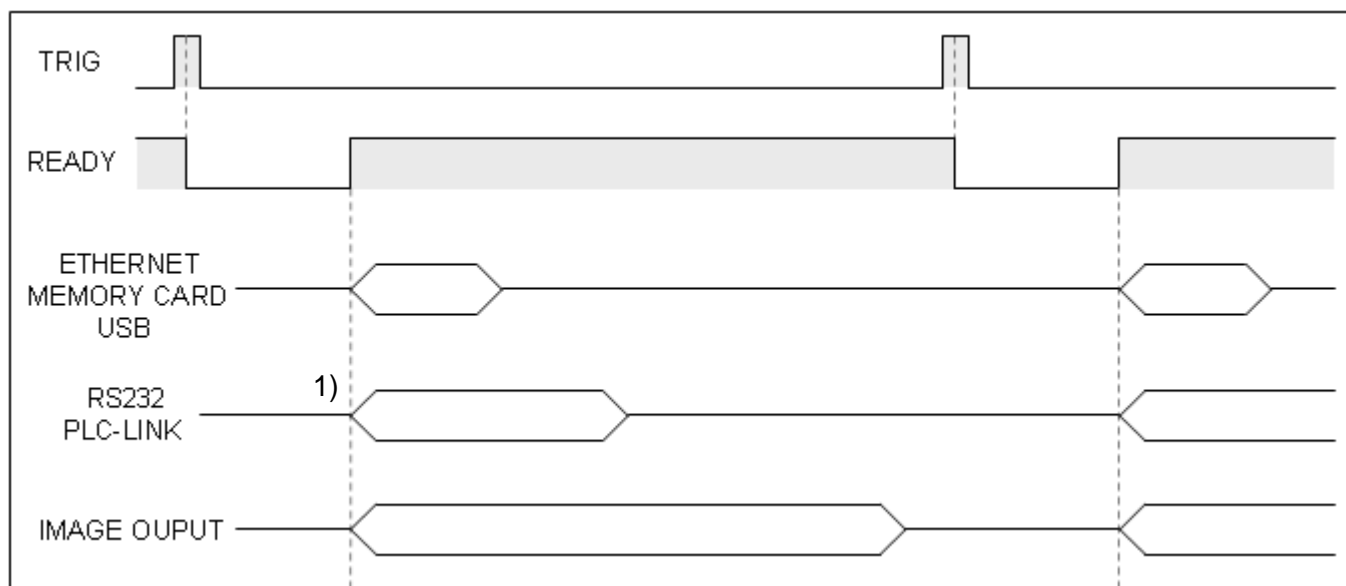

Description:

The outputs are in sync with the READY ON signal.

Remark To set the communication speed, click **ETHERNET > RS232 > IMAGE OUTPUT**.

7.2.5 Function Switch: FNC1–4, IN1–8, FRDY, FCH, SW, NSW

The non-imaging and imaging inspection functions can be switched through the I/O terminals; for example, switching between inspection projects or adjusting the camera shutter speed.

Function Selection				Description of Function	Setting Value
FNC4	FNC3	FNC2	FNC1		IN8–IN1
OFF	OFF	OFF	OFF	0: Switch process (internal memory)	0–31 (IN5–IN1 configurations)
OFF	OFF	OFF	ON	1: Switch process (SD card)	
OFF	OFF	ON	OFF	2: Switch viewing window	0–127 (IN7–IN1 configurations)
OFF	OFF	ON	ON	3: Modify shutter speed	Shutter 0–9 (IN4–IN1); camera No. 0–1 (IN8)
OFF	ON	OFF	OFF	4: Camera gain	Gain 0–100 (IN7–IN1); camera No. 0–1 (IN8)
OFF	ON	OFF	ON	5: Camera brightness	Brightness 0–100 (IN7–IN1); camera No. 0–1 (IN8)
OFF	ON	ON	OFF	6: Image capture	N/A

► IN8–IN1 numerical input table: (O=ON, X=OFF)

Numerical Value	Switch state							
	IN8	IN7	IN6	IN5	IN4	IN3	IN2	IN1
0	X	X	X	X	X	X	X	X
1	X	X	X	X	X	X	X	O
2	X	X	X	X	X	X	O	X
3	X	X	X	X	X	X	O	O
4	X	X	X	X	X	O	X	X
5	X	X	X	X	X	O	O	O
6	X	X	X	X	X	O	O	X
7	X	X	X	X	X	O	O	O
8	X	X	X	X	O	X	X	X
9	X	X	X	X	O	X	X	O
10	X	X	X	X	O	X	O	X
11	X	X	X	X	O	X	O	O
12	X	X	X	X	O	O	X	X
13	X	X	X	X	O	O	X	O
14	X	X	X	X	O	O	O	X
15	X	X	X	X	O	O	O	O
16	X	X	X	O	X	X	X	X
17	X	X	X	O	X	X	X	O
18	X	X	X	O	X	X	O	X
19	X	X	X	O	X	X	O	O
20	X	X	X	O	X	O	X	X
21	X	X	X	O	X	O	X	O
22	X	X	X	O	X	O	O	X
23	X	X	X	O	X	O	O	O
24	X	X	X	O	O	X	X	X

Numerical Value	Switch state							
	IN8	IN7	IN6	IN5	IN4	IN3	IN2	IN1
32	X	X	O	X	X	X	X	X
33	X	X	O	X	X	X	X	O
34	X	X	O	X	X	X	O	X
35	X	X	O	X	X	X	O	O
36	X	X	O	X	X	O	X	X
37	X	X	O	X	X	O	X	O
38	X	X	O	X	X	O	O	X
39	X	X	O	X	X	O	O	O
40	X	X	O	X	O	X	X	X
41	X	X	O	X	O	X	X	O
42	X	X	O	X	O	X	O	X
43	X	X	O	X	O	X	O	O
44	X	X	O	X	O	O	X	X
45	X	X	O	X	O	O	X	O
46	X	X	O	X	O	O	O	X
47	X	X	O	X	O	O	O	O
48	X	X	O	O	X	X	X	X
49	X	X	O	O	X	X	X	O
50	X	X	O	O	X	X	O	X
51	X	X	O	O	X	X	O	O
52	X	X	O	O	X	O	X	X
53	X	X	O	O	X	O	X	O
54	X	X	O	O	X	O	O	X
55	X	X	O	O	X	O	O	O
56	X	X	O	O	O	X	X	X

Chapter 7 Input and Output I/O Terminal

25	X	X	X	O	O	X	X	O
26	X	X	X	O	O	X	O	X
27	X	X	X	O	O	X	O	O
28	X	X	X	O	O	O	X	X
29	X	X	X	O	O	O	X	O
30	X	X	X	O	O	O	O	X
31	X	X	X	O	O	O	O	O
Numerical Value	Switch state							
	IN8	IN7	IN6	IN5	IN4	IN3	IN2	IN1
64	X	O	X	X	X	X	X	X
65	X	O	X	X	X	X	X	O
66	X	O	X	X	X	X	O	X
67	X	O	X	X	X	X	O	O
68	X	O	X	X	X	O	X	X
69	X	O	X	X	X	O	X	O
70	X	O	X	X	X	O	O	X
71	X	O	X	X	X	O	O	O
72	X	O	X	X	O	X	X	X
73	X	O	X	X	O	X	X	O
74	X	O	X	X	O	X	O	X
75	X	O	X	X	O	X	O	O
76	X	O	X	X	O	O	X	X
77	X	O	X	X	O	O	X	O
78	X	O	X	X	O	O	O	X
79	X	O	X	X	O	O	O	O
80	X	O	X	O	X	X	X	X
81	X	O	X	O	X	X	X	O
82	X	O	X	O	X	X	O	X
83	X	O	X	O	X	X	O	O
84	X	O	X	O	X	O	X	X
85	X	O	X	O	X	O	X	O
86	X	O	X	O	X	O	O	X
87	X	O	X	O	X	O	O	O
88	X	O	X	O	O	X	X	X
89	X	O	X	O	O	X	X	O
90	X	O	X	O	O	X	O	X
91	X	O	X	O	O	X	O	O
92	X	O	X	O	O	O	X	X
93	X	O	X	O	O	O	X	O
94	X	O	X	O	O	O	O	X
95	X	O	X	O	O	O	O	O

57	X	X	O	O	O	X	X	O
58	X	X	O	O	O	X	O	X
59	X	X	O	O	O	X	O	O
60	X	X	O	O	O	O	X	X
61	X	X	O	O	O	O	X	O
62	X	X	O	O	O	O	O	X
63	X	X	O	O	O	O	O	O
Numerical Value	Switch state							
	IN8	IN7	IN6	IN5	IN4	IN3	IN2	IN1
96	X	O	O	X	X	X	X	X
97	X	O	O	X	X	X	X	O
98	X	O	O	X	X	X	O	X
99	X	O	O	X	X	X	O	O
100	X	O	O	X	X	O	X	X
101	X	O	O	X	X	O	X	O
102	X	O	O	X	X	O	O	X
103	X	O	O	X	X	O	O	O
104	X	O	O	X	O	X	X	X
105	X	O	O	X	O	X	X	O
106	X	O	O	X	O	X	O	X
107	X	O	O	X	O	X	O	O
108	X	O	O	X	O	O	X	X
109	X	O	O	X	O	O	X	O
110	X	O	O	X	O	O	O	X
111	X	O	O	X	O	O	O	O
112	X	O	O	O	X	X	X	X
113	X	O	O	O	X	X	X	O
114	X	O	O	O	X	X	O	X
115	X	O	O	O	X	X	O	O
116	X	O	O	O	X	O	X	X
117	X	O	O	O	X	O	X	O
118	X	O	O	O	X	O	O	X
119	X	O	O	O	X	O	O	O
120	X	O	O	O	O	X	X	X
121	X	O	O	O	O	X	X	O
122	X	O	O	O	O	X	O	X
123	X	O	O	O	O	X	O	O
124	X	O	O	O	O	O	X	X
125	X	O	O	O	O	O	X	O
126	X	O	O	O	O	O	O	X
127	X	O	O	O	O	O	O	O

► Non-imaging (inspection) mode:

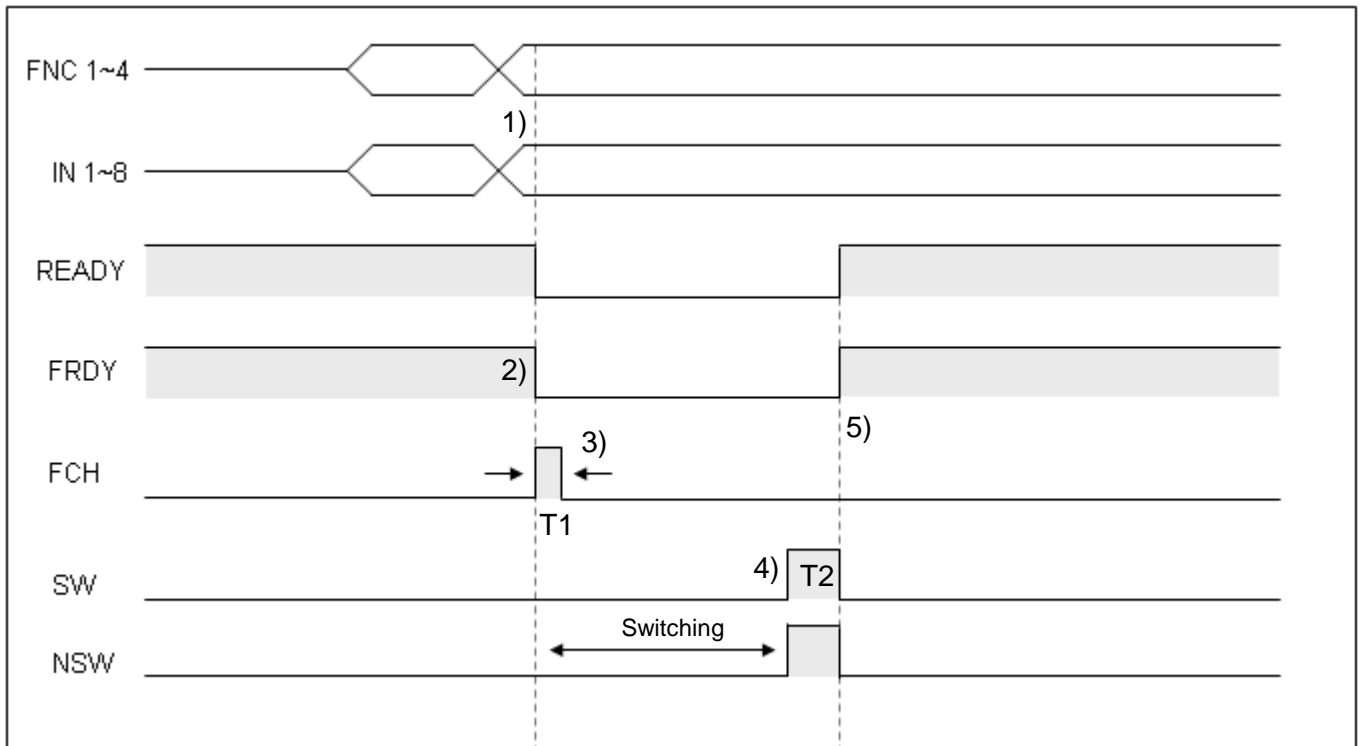

Description:

- 1) Enable FNC 1–4 and IN 1–8 to set up the function and parameters.
- 2) When FRDY (Function Ready) is ON, function switching can be enabled.
- 3) Trigger FCH (Function Change) to execute function switching (T1 must be longer than 1 ms). After FCH is enabled, READY and FRDY are OFF.
- 4) After the switch is made, one of the output flags, SW (success) or NSW (fail), is sent out to notify whether the switch was successful. If switching is disabled or illegal, the NSW flag output is set. You configure T2 by clicking **System > Communication Setting > Protocol Setting > External Terminal**.

The following picture shows **SW and NSW** set to 20 ms, and the SW or NSW output using a 20-ms pulse width to indicate whether the switch was made successfully after each switch.



- 5) When any output from SW or NSW is complete, READY and FRDY signals are set to ON.

► Imaging (inspection) mode

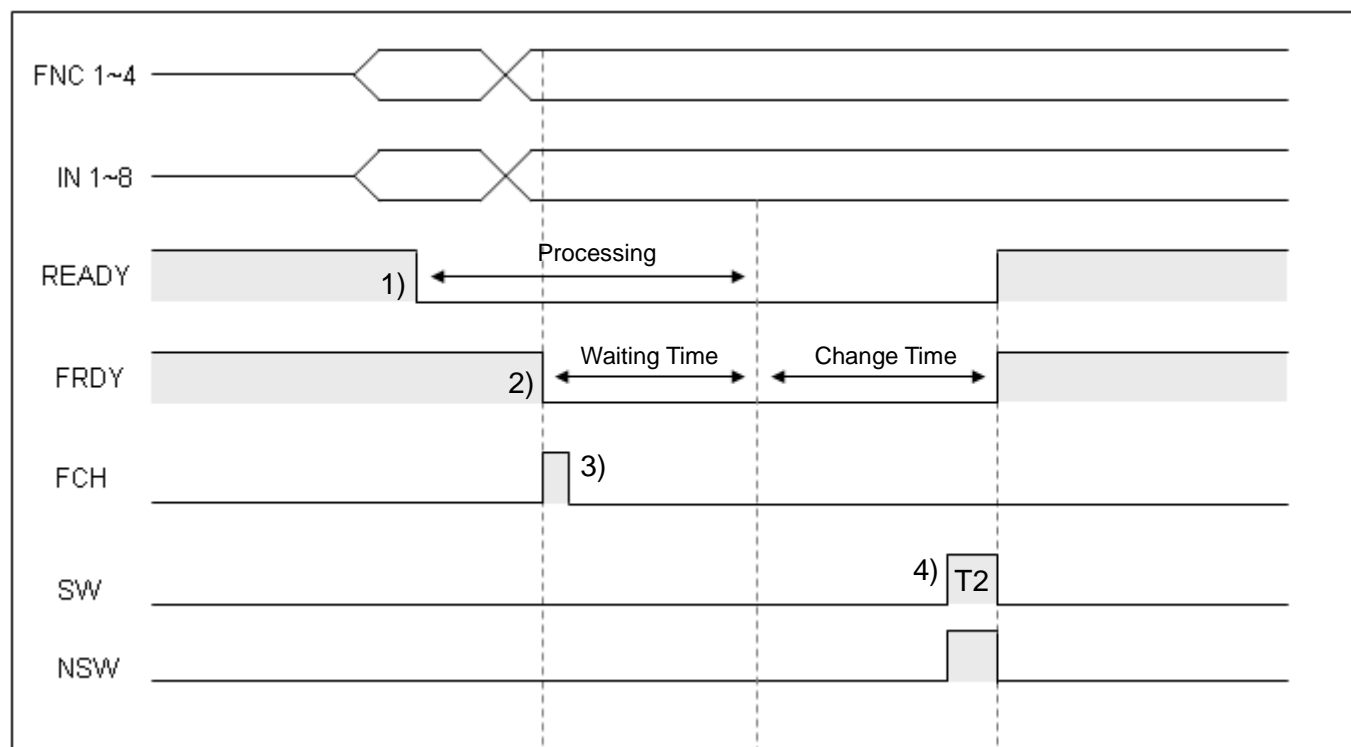

Description:

- 1) When READY is OFF, the system is under image processing condition.
- 2) FRDY is ON, function switching is enabled.
- 3) FCH is triggered to initiate function switching (T1 must be longer than 1 ms). After FCH is enabled, FRDY is OFF.

Image processing must be completed before the function can be switched.

- 4) After the switch is made, one of the output flags, SW (success) or NSW (fail), is sent out to notify whether the switch was successful. If switching is disabled or illegal, the NSW flag output is set.

You configure T2 by clicking **System > Communication Setting > Protocol Setting > External Terminal**.

In the following picture shows SW and NSW set to 20 ms, and the SW or NSW output using 20-ms pulse width to indicate whether the switch was made successfully after each switch.

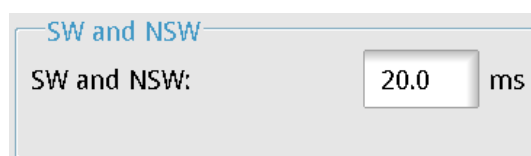

- 5) When any output from SW or NSW is complete, READY and FRDY signals are set to ON.

7.2.6 Others: TROFF, TEST, RESET

► TROFF (trigger disabled)

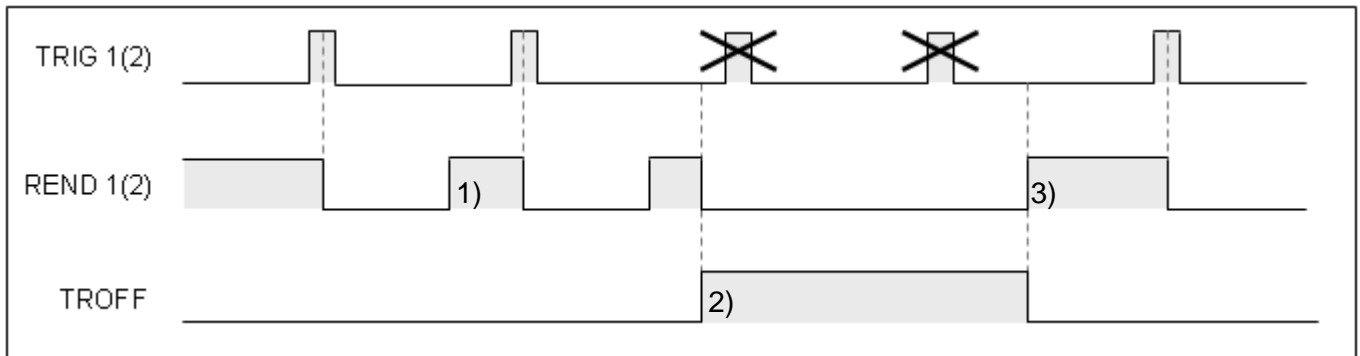

Description:

- 1) During standard timing sequence, REND is ON after the image is captured to allow the next trigger input.
- 2) When TROFF input is ON, REND1 and REND2 are disabled at the same time. You can use either the TROFF or REND signals as the trigger point.
- 3) When TROFF is OFF, REND1 and REND2 signals resume normal operation.

► TEST (output disabled)

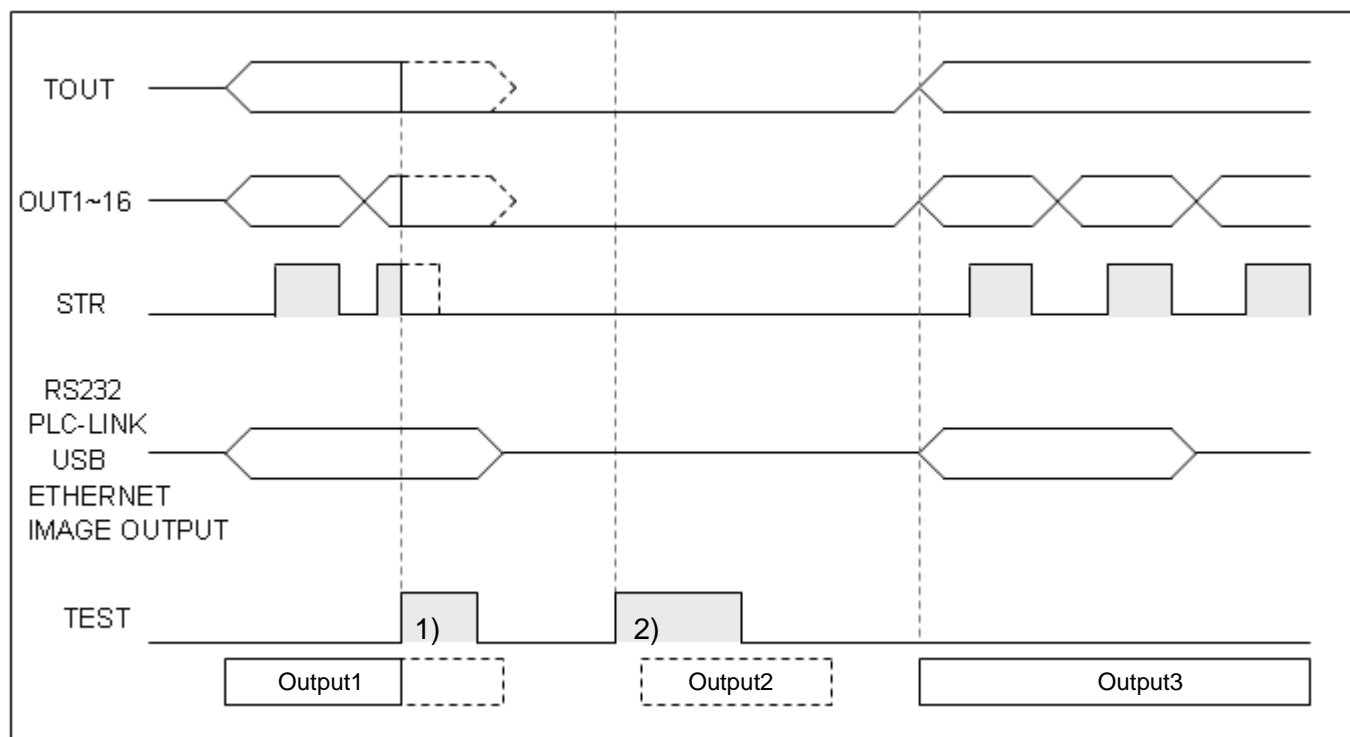

Description:

- 1) Output1 is valid before TEST input is ON, and all external output terminals are OFF and communication output is uninterrupted until the sequence ends.
- 2) TEST input occurs before Output2, therefore external output terminals and communication outputs are disabled.

► RESET

When RESET signal input is enabled, all outputs are disabled.

Chapter 8

Serial Communication

8.1 RS232/RS485 Serial Communication Mode

The following four types of serial communication methods are available.

◎ **Private Code Mode (DMV2000 in Master Mode)**

After each inspection, the system sends the configured output results through the RS232 and RS485 communication ports in custom DMV2000 communication format. After receiving the communication strings, you must use the DMV2000-defined method to work with the result data.

◎ **RS232/RS485 PLC Automatic Link Mode (DMV2000 in Master Mode)**

After each inspection, the system automatically writes the configured output results into the assigned PLC register. This eliminates the decoding step after string reception, and simplifies the programming work. You can access the required numerical results directly from the register in the PLC. PLC automatic link is currently supported by the Delta DVP series PLCs only.

◎ **RS232/RS485 Modbus Communication Format (DMV2000 in Master Mode)**

Select **RS232** or **RS485** in the **Result Output** in the flow process, and then the data is automatically sent in Modbus format to a mechanical arm or other manufacturer's PLC after the inspection.

◎ **RS232/RS485 Modbus Communication Format (DMV2000 in Slave Mode)**

When you select **Modbus**, the controller automatically switches to slave mode without configuring the output. This enables external Modbus commands, prompting a response from the controller. The commands used in the Modbus communication format are identical to those of the Ethernet Modbus TCP. Please refer to Section 8.5.3 for more information about the Modbus command format.

 **Remark** You can select only one of the four communication methods. After you confirm the selection, the RS232, RS485, and Ethernet interfaces all adopt the same settings.

8.2 RS232/RS485 Private Code Communication Mode

In private code communication, the system automatically sends out the results from the DMV2000 after completing the inspection. After the superior controller receives the strings, the required results are generated through manual decoding according to the defined format. In addition to transmitting inspection results, the private code method also supports multiple written control commands.

This section explains the private code communication format configurations for RS232 and RS485.

- Configure the communication format: in the Main window, click **System > Communication Setting > Device Setting > RS232 or RS485**.

The screenshot shows the 'Device Setting' window with the 'RS232' option selected. The settings are as follows:

External Terminal	Baud Rate:	115200
Ethernet	Stop Bit:	<input checked="" type="radio"/> 1 <input type="radio"/> 2
RS232	Parity Bit:	<input checked="" type="radio"/> None <input type="radio"/> Odd <input type="radio"/> Even
RS485	Data Bit:	<input type="radio"/> 7-bit <input checked="" type="radio"/> 8-bit

- Enter the DMV2000 host station number in the RS485 ID.

The screenshot shows the 'Device Setting' window with the 'RS485' option selected. The settings are as follows:

External Terminal	Baud Rate:	115200
Ethernet	Stop Bit:	<input checked="" type="radio"/> 1 <input type="radio"/> 2
RS232	Parity Bit:	<input checked="" type="radio"/> None <input type="radio"/> Odd <input type="radio"/> Even
RS485	Data Bit:	<input type="radio"/> 7-bit <input checked="" type="radio"/> 8-bit
	ID:	1

- Click **System > Communication Setting > Protocol Setting > RS232 or RS485**, and then select **Private Code**.

The screenshot shows the 'Protocol Setting' dialog box. On the left, there are four buttons: 'External Terminal', 'Ethernet', 'RS232', and 'RS485'. The 'External Terminal' button is highlighted. To the right, the 'Data Format' is set to '16 Bits' in a dropdown menu. Below that, the 'Protocol' is set to 'Private Code' (indicated by a selected radio button), with 'PLC Link' as an alternative. A 'Detail Setup' button is located below the protocol options.

Reference The private code result output can also use a user-defined format (refer to Section 8.2.3).

8.2.1 Private Code Mode Command Table: (DMV2000 Custom Communication Format)

	Function	Input string	Return string	Permission	
				Run	Edit
1	Trigger 1 action and output	T1 [CR] [LF]	T1 [CR] [LF] T0 + Output Data [CR]	O	
2	Trigger 2 action and output	T2 [CR] [LF]	T2 [CR] [LF] T0 + Output Data [CR]	O	
3	Trigger 3 action and output	T3 [CR] [LF]	T3 [CR] [LF] T0 + Output Data [CR]	O	
4	Trigger 4 action and output	T4 [CR] [LF]	T4 [CR] [LF] T0 + Output Data [CR]	O	
5	Go to Run mode	RN [CR] [LF]	RN [CR] [LF]		O
6	Go to Edit mode	PG [CR] [LF]	PG [CR] [LF]	O	
7	Repeat data output	DQ [CR] [LF]	DQ + Output Data [CR] [LF]	O	
8	Switch program ID	PCnnnn [CR] [LF]	PC [CR] [LF]	O	O
9	Read program ID	PR [CR] [LF]	PRnnnn [CR] [LF]	O	
10	Switch window ID	WCwnnnn [CR] [LF]	WC [CR] [LF]	O	
11	Read window ID	WR [CR] [LF]	WRwnnnn [CR] [LF]	O	
12	Capture image	CP [CR] [LF]	CP [CR] [LF]	O	O
13	Enable input trigger	TO [CR] [LF]	TO [CR] [LF]	O	

14	Disable input trigger	TF <input type="text" value="CR"/> <input type="text" value="LF"/>	TF <input type="text" value="CR"/> <input type="text" value="LF"/>	O	
15	Write upper/lower (Window)	LWWmnnnnnaaaaaaabbbbb bbb <input type="text" value="CR"/> <input type="text" value="LF"/>	LW <input type="text" value="CR"/> <input type="text" value="LF"/>	O	
16	Write upper/lower limit (calculator)	LWCAnnaaaaaaabbbbbbbb <input type="text" value="CR"/> <input type="text" value="LF"/>	LC <input type="text" value="CR"/> <input type="text" value="LF"/>	O	
17	Read upper/lower (Window)	LRWmnnnn <input type="text" value="CR"/> <input type="text" value="LF"/>	LRaaaaaaabbbbbbbb <input type="text" value="CR"/> <input type="text" value="LF"/>	O	
18	Read upper/lower limit (calculator)	LRCAnn <input type="text" value="CR"/> <input type="text" value="LF"/>	LRaaaaaaabbbbbbbb <input type="text" value="CR"/> <input type="text" value="LF"/>	O	
19	Save all program setting	SV <input type="text" value="CR"/> <input type="text" value="LF"/>	SV <input type="text" value="CR"/> <input type="text" value="LF"/>		O
20	Set time/date	DWyyymmddhhmmss <input type="text" value="CR"/> <input type="text" value="LF"/>	DW <input type="text" value="CR"/> <input type="text" value="LF"/>	O	O
21	Read time/date	DR <input type="text" value="CR"/> <input type="text" value="LF"/>	DRyyymmddhhmmss <input type="text" value="CR"/> <input type="text" value="LF"/>	O	O
22	Set camera shutter speed	SHCnmm <input type="text" value="CR"/> <input type="text" value="LF"/>	SH <input type="text" value="CR"/> <input type="text" value="LF"/>	O	
23	Set camera gain and brightness	SECnmmkkk <input type="text" value="CR"/> <input type="text" value="LF"/>	SE <input type="text" value="CR"/> <input type="text" value="LF"/>	O	
24	Clear statistics	QC <input type="text" value="CR"/> <input type="text" value="LF"/>	QC <input type="text" value="CR"/> <input type="text" value="LF"/>	O	O
25	System reset	RS <input type="text" value="CR"/> <input type="text" value="LF"/>	RS <input type="text" value="CR"/> <input type="text" value="LF"/>	O	

8.2.2 Private Code Mode Command: (DMV2000 Communication Format)

1) Trigger 1 Action and Output Data (Run Mode enabled)

Input string: T1 Return string: T1 T0 +Output Data

© Description:

- Set string length to 5 for two data (1234, 345) and three judgments (1, 0, 1) in the case of integers.
Return: T1 T00123400345101
- Set string length to 5 for two data (12.3, 34.5) and three judgments (1, 0, 1) in the case of decimals.
Return: T1 T01230034500101

The system returns T1 upon receiving the command, and then returns the result after the inspection completes. Inspection time varies with the inspection item. Increase the controller timeout as required if the inspection time is too long.

- ◎ **Error Handling:** return string
 - E01: incorrect permission mode (incorrect Run/Edit mode)
 - E02: incorrect string data (string length is too long or too short to be recognized)
 - E03: READY is not ON and cannot execute (confirm the I/O status)
 - E14: incorrect trigger source interface
 - E15: inconsistent operating and configured trigger IDs
 - E17: system busy, cannot respond

2) Trigger 2 Action and Output Data (Run Mode enabled)

Input string: T2 Return string: T2 T0 + Output Data

- ◎ **Description:**
 - Set string length to 5 for two data (1234, 345) and three judgments (1, 0, 1) in the case of integers.
Return: T2 T00123400345101
 - Set string length to 5 for two data (12.3, 34.5) and three judgments (1, 0, 1) in the case of integers.
Return: T2 T01230034500101
- The system returns T2 upon receiving the command, and then returns the result after the inspection completes. Inspection time varies with the inspection item. Increase the controller timeout as required if the inspection time is too long.

- ◎ **Error Handling:** return string
 - E01: incorrect permission mode (incorrect Run/Edit mode)
 - E02: incorrect string data (string length is too long or too short to be recognized)
 - E03: READY is not ON and cannot execute (please confirm the I/O status)
 - E14: incorrect trigger source interface
 - E15: inconsistent operating and configured trigger IDs
 - E17: system busy, cannot respond

3) Trigger 3 Action and Output Data (Run Mode enabled)

Input string: T3 Return string: T3 T0 + Output Data

- ◎ **Description:**
 - Set string length to 5 for two data (1234, 345) and three judgments (1, 0, 1) in the case of integers.
Return: T3 T00123400345101
 - Set string length to 5 for two data (12.3, 34.5) and three judgments (1, 0, 1) in the case of integers.
Return: T3 T01230034500101
- The system returns T3 upon receiving the command, and then returns the result after the inspection completes. Inspection time varies with the inspection item. Increase the controller timeout as required if the inspection time is too long.

◎ **Error handling:** return string

- E01: incorrect permission mode (incorrect Run/Edit mode)
- E02: incorrect string data (string length is too long or too short to be recognized)
- E03: READY is not ON and cannot execute (confirm the I/O status)
- E14: incorrect trigger source interface
- E15: inconsistent operating and configured trigger IDs
- E17: system busy, cannot respond

4) Trigger 4 Action and Output Data (Run Mode enabled)

Input string: T4 Return string: T4 T0 + Output Data

◎ **Description:**

- Set string length to 5 for two data (1234, 345) and three judgments (1, 0, 1) in the case of integers.

Return: T4 T00123400345101

- Set string length to 5 for two data (12.3, 34.5) and three judgments (1, 0, 1) in the case of integers.

Return: T4 T01230034500101

The system returns T4 upon receiving the command, and then returns the result after the inspection completes. Inspection time varies with the inspection item. Increase the controller timeout as required if the inspection time is too long.

◎ **Error Handling:** return string

- E01: incorrect permission mode (incorrect Run/Edit mode)
- E02: incorrect string data (string length is too long or too short to be recognized)
- E03: READY is not ON and cannot execute (please confirm the I/O status)
- E14: incorrect trigger source interface
- E15: inconsistent operating and configured trigger IDs
- E17: system busy, cannot respond

5) To Run Mode (Edit Mode enabled)

Input string: RN Return string: RN

◎ **Error Handling:** return string

- E01: incorrect permission mode (incorrect Run/Edit mode)
- E02: incorrect string data (string length is too long or too short to be recognized)
- E03: FRDY (function ready) is not ON and cannot execute (confirm the I/O status)
- E05: program ID does not exist (or program ID not set)
- E17: system busy, cannot respond

6) To Setting Mode (Run Mode enabled)

Input string: PG Return string: PG

⊙ **Error Handling:** Return string

- E01: incorrect permission mode (incorrect Run/Edit Run/Edit mode)
- E02: incorrect string data (string length is too long or too short to be recognized)
- E03: FRDY (Function Ready) is not ON and cannot execute (confirm the I/O status)
- E17: system busy, cannot respond

7) Repeat Output Data (Run Mode enabled)

Input string: DQ Return string: DQ + Output data

⊙ **Description:**

Controller returns the latest inspection result.

Error message is returned if there is no inspection result to return; for example: system bootup before an inspection cycle.

⊙ **Error Handling:** return string

- E01: incorrect permission mode (incorrect Run/Edit Run/Edit mode)
- E02: incorrect string data (string length is too long or too short to be recognized)
- E17: system busy, cannot respond

8) Switch Program ID (Run Mode and Edit Mode enabled)

Input string: PCnnnn Return string: PC

⊙ **Description:**

nnnn is program ID (valid internal memory program ID P0000–P9999)

Enter the string to switch the program ID to P0003: PC0003

⊙ **Error Handling:** return string

- E02: incorrect string data (string length is too long or too short to be recognized)
- E03: FRDY (function ready) is not ON and cannot execute (confirm the I/O status)
- E05: program ID does not exist (or program ID not set)
- E17: system busy, cannot respond

9) Read Program ID (^ Run Mode enabled)

Input string: PR Return string: PRnnnn

⊙ **Description:**

nn is program ID.

If the current program ID is internal memory P0003, then the controller returns the string: PR0003

⊙ **Error Handling:** return string

- E01: incorrect permission mode (incorrect Run/Edit Run/Edit mode)
- E02: incorrect string data (string length is too long or too short to be recognized)
- E17: system busy, cannot respond

10) Switch Window ID (Run Mode enabled)

Input string: WCwnnnn Return string: WC

⊙ **Description:**

nnnn is window ID (valid window ID W0000–W0999)

Please enter the string to switch to W0015: WCw0015

⊙ **Error Handling:** return string

- E01: incorrect permission mode (incorrect Run/Edit mode)
- E02: incorrect string data (string length is too long or too short to be recognized)
- E03: FRDY (function ready) is not ON and cannot execute (please confirm the I/O status)
- E06: window ID does not exist (or window ID not set)
- E17: system busy, cannot respond

11) Read Window ID (Run Mode enabled)

Input string: WR Return string: WRwnnnn

⊙ **Description:** nnnn is window ID.

If the current window ID is W0020, the controller returns the string: WRw0020

⊙ **Error Handling:** return string

- E01: incorrect permission mode (incorrect Run/Edit mode)
- E02: incorrect string data (string length is too long or too short to be recognized)
- E17: system busy, cannot respond

12) Capture Image (Run Mode and Edit Mode enabled)Input string: CP Return string: CP

- ⊙ **Description:** copy current screen to SD card.
- ⊙ **Error Handling:** return string
 - E02: incorrect string data (string length is too long or too short to be recognized)
 - E07: no SD card found
 - E09: insufficient memory or SD card space
 - E17: system busy, cannot respond

13) Enable Trigger Input (Run Mode enabled)Input string: TO Return string: TO

- ⊙ **Description:** the controller remains in the Trigger Enabled state during each bootup; therefore you can use this command with the Disable Trigger Input command.
- ⊙ **Error Handling:** return string
 - E01: incorrect permission mode (incorrect Run/Edit mode)
 - E02: incorrect string data (string length is too long or too short to be recognized)
 - E17: system busy, cannot respond

14) Disable Trigger Input (Run Mode enabled)Input string: TF Return string: TF

- ⊙ **Description:** disable all enabled trigger sources
Set the trigger source in the DMV2000 Main window; click **Program > Camera > Trigger**
- ⊙ **Error Handling:** return string
 - E01: incorrect permission mode (incorrect Run/Edit mode)
 - E02: incorrect string data (string length is too long or too short to be recognized)
 - E17: system busy, cannot respond

15) Write Upper/Lower Data - Window (Run Mode enabled)Input string: LWWmnnnnnaaaaaaabbabbbbbbb Return string: LW

- ⊙ **Description:** m denotes the data ID (see Table 1 below), nnnn represents the window ID, aaaaaaaa is the upper limit, and bbbabbbbb is the lower limit. The upper and lower limits are fixed eight-digit numbers.

To configure the upper/lower limits of W015 to 300 and 200, enter the string:

LWW200150003000000020000

If the upper or lower input limits are coordinates or angle data (hundredth decimal format), you can enter the data using the following method.

To enter the upper and lower range of angles to 120.00 and 50.00, enter the string:

LWW200150001200000005000

⊙ **Error Handling:** return string

- E01: incorrect permission mode (incorrect Run/Edit mode)
- E02: incorrect string data (string length is too long or too short to be recognized)
- E03: FRDY (function ready) is not ON and cannot execute (please confirm the I/O status)
- E06: window ID does not exist (or window ID not set)
- E08: upper/lower input error (invalid range or Upper is less than Lower)
- E14: incorrect data ID (not available from current inspection)
- E17: system busy, cannot respond

16) Write Upper/Lower Data - Calculator (Run Mode enabled)

Input string: LWCAnnaaaaaaaaaabbbbbbbb Return string: LC

⊙ **Description:** nn (calculator ID), aaaaaaaaaa (upper limit), bbbbbbbbbb (lower limit). The upper and lower limits are fixed eight-digit numbers.

To set the calculator C25's upper and lower to 123.45 and 12.34, enter the string:

LWCA250001234500001234

⊙ **Error Handling:** return string

- E01: incorrect permission mode (incorrect Run/Edit mode)
- E02: incorrect string data (string length is too long or too short to be recognized)
- E03: FRDY (function ready) is not ON and cannot execute (please confirm the I/O status)
- E06: calculator ID does not exist (or calculator ID not set)
- E08: upper/lower input error (exceeds range or Upper is less than Lower)
- E17: system busy, cannot respond

17) Read Upper/Lower Data - Window (Run Mode enabled)

Input string: LRWmnnnn Return string: LRaaaaabbbbb

⊙ **Description:** m denotes the data ID (see Table 1 below), nnnn represents the window ID, aaaaaaaa is the upper limit, and bbbbbbbb is the lower limit. The upper and lower limits are fixed eight-digit numbers.

If Window W015's upper and lower read limits are 3.00 and 2.00, send the string LRW20015

Return string LR0000030000000200

If the upper or lower read limits are coordinates or angle data (hundredth decimal format), the data is returned using the following method.

If the upper/and lower limits are 120.00 and 50.00, the return string is LR0001200000005000

◎ **Error Handling:** return string

- E01: incorrect permission mode (incorrect Run/Edit mode)
- E02: incorrect string data (string length is too long or too short to be recognized)
- E06: window ID does not exist (or window ID not set)
- E14: incorrect data ID (not available from current inspection)
- E17: system busy, cannot respond

(Table 1)

Item Number	Area	Description
0	Total area	000000–999999
Item Number	Position	Description
0	Horizontal position	-99999.99 to 99999.99
1	Vertical position	-99999.99 to 99999.99
2	Angle	-180 to 180
Item Number	Count	Description
0	Number	0–999
Item Number	Width	Description
0	Width	-99999.99 to 99999.99
1	Horizontal position	-99999.99 to 99999.99
2	Vertical position	-99999.99 to 99999.99
3	Angle	-180 to 180
Item Number	Pitch	Description
0	Number	0–99
1	Width	-99999.99 to 99999.99
2	Maximum width	-99999.99 to 99999.99
3	Minimum width	-99999.99 to 99999.99
4	Average width	-99999.99 to 99999.99
Item Number	Angle	Description
0	Angle	-180 to 180
Item Number	Shape	Description
0	Number	0–999
1	Horizontal position	-99999.99 to 99999.99
2	Vertical position	-99999.99 to 99999.99

Chapter 8 Serial Communication

3	Similarity	0–100
4	Angle	-180 to 180
Item Number	Spot	Description
0	Number	0–999
1	Horizontal position	-99999.99 to 99999.99
2	Vertical position	-99999.99 to 99999.99
3	Area	0–999999
4	Circumference	0–999999
Item Number	Stain	Description
0	Total area	0–999999
1	Area	0–999999
2	Horizontal position	-99999.99 to 99999.99
3	Vertical position	-99999.99 to 99999.99
4	Number	0–999
Item Number	Intensity	Description
0	Average brightness	0–255
1	Standard brightness deviation	0–255
2	Max brightness	0–255
3	Min brightness	0–255
Item Number	Position Trace	Description
0	Maximum horizontal position	-99999.99 to 99999.99
1	Maximum vertical position	-99999.99 to 99999.99
2	Minimum horizontal position	-99999.99 to 99999.99
3	Minimum vertical position	-99999.99 to 99999.99
4	Roundness	0–100.00
Item Number	Width Trace	Description
0	Maximum width	0–99999.99
1	Minimum width	0–99999.99
2	Average width	0–99999.99
3	Roundness1	0–100.00
4	Roundness2	0–100.00
Item Number	Pattern Comparison	Description
0	Number	0–999
1	Horizontal position	-99999.99 to 99999.99
2	Vertical position	-99999.99 to 99999.99
3	Similarity	0–100
4	Angle	-180 to 180

18) Read Upper/Lower Data - Calculator (Run Mode enabled)

Input string: LRCAnn Return string: LRaaaaaaaabbbbbbbb

- ⊙ **Description:** nn (calculator ID), aaaaaaaa (upper limit), bbbbbbbb (lower limit). The upper and lower limits are fixed eight-digit numbers.

If the Calculator C25's upper and lower read limits are 123.45 and 12.34, the return string is

LR0001234500001234

- ⊙ **Error Handling:** return string
 - E01: incorrect permission mode (incorrect Run/Edit mode)
 - E02: incorrect string data (string length is too long or too short to be recognized)
 - E06: calculator ID does not exist (or calculator ID not set)
 - E17: system busy, cannot respond

19) Save All Program Setting (Edit Mode enabled)

Input string: SV Return string: SV

- ⊙ **Error Handling:** return string
 - E01: incorrect permission mode (incorrect Run/Edit mode)
 - E02: incorrect string data (string length is too long or too short to be recognized)
 - E07: no SD card found
 - E09: insufficient memory or SD card space
 - E17: system busy, cannot respond

20) Set Date/Time (Run Mode and Edit Mode enabled)

Input string: DWyymmddhhmmss Return string: DW

- ⊙ **Error Handling:** return string
 - E02: incorrect string data (string length is too long or too short to be recognized)
 - E10: incorrect calendar format
 - E17: system busy, cannot respond

21) Read Date/Time (Run Mode and Edit Mode enabled)

Input string: DR Return string: DRyymmddhhmmss

- ⊙ **Error Handling:** return string
 - E02: incorrect string data (string length is too long or too short to be recognized)
 - E17: system busy, cannot respond

22) Configure Camera Shutter Speed (Run Mode enabled)

Input string: SHCnmm Return string: SH

- ⊙ **Description:** n denotes the camera ID (1–8) and mm represents the shutter speed option
Shutter speed configuration table (range 01–20)

01 = 6000ms	05 = 2000ms	09 = 33.33ms	13 = 4.17ms	17 = 0.2ms
02 = 5000ms	06 = 1000ms	10 = 16.67ms	14 = 2ms	18 = 0.1ms
03 = 4000ms	07 = 500ms	11 = 10ms	15 = 1ms	19 = 0.05ms
04 = 3000ms	08 = 66.67ms	12 = 8.33ms	16 = 0.5ms	20 = 0.025ms

- ⊙ **Error Handling:** return string
 - E01: incorrect permission mode (incorrect Run/Edit mode)
 - E02: incorrect string data (string length is too long or too short to be recognized)
 - E11: incorrect camera settings.
 - E17: system busy, cannot respond

23) Configure Camera Gain and Luminance (Run Mode enabled)

Input string: SECnmmkkk Return string: SE

- ⊙ **Description:** n denotes the camera ID (1–8), mmm represents the gain, and kkk is the luminance (mmm and kkk are configured between 00–100).
- ⊙ **Error Handling:** return string
 - E01: incorrect permission mode (incorrect Run/Edit mode)
 - E02: incorrect string data (string length is too long or too short to be recognized)
 - E11: incorrect camera settings.
 - E17: system busy, cannot respond

 **Remark** Higher gain can compensate for insufficient lighting, but may also add noise to the image.

24) Clear Statistics (Run Mode and Edit Mode enabled)

Input string: QC Return string: QC

- **Error Handling:** return string
 - E02: incorrect string data (string length is too long or too short to be recognized)
 - E17: system busy, cannot respond

25) System Reset (Run Mode enabled)

Input string: RS Return string: RS

- **Description:** reset clears the following data:
Total, NG, defect rate, statistics, output terminals
- **Error Handling:** return string
 - E02: incorrect string data (string length is too long or too short to be recognized)
 - E17: system busy, cannot respond

Return Error Message Table

Error Code	Description
E01	Incorrect mode enabled (incorrect Run/Edit mode)
E02	Incorrect string content (string length is too long or too short to be recognized)
E03	READY is not ON and cannot be executed (please confirm the I/O status)
	FRDY (function ready) is not ON and cannot be executed (please confirm the I/O status)
E04	Result does not exist
E05	Program ID does not exist (or program ID not set)
E06	Window ID does not exist (or window ID not set)
	Calculator ID does not exist (or calculator ID not set)
E07	No SD card
E08	Upper or lower input error (invalid range or upper is less than lower)
E09	Insufficient memory or SD card space
	Memory address does not exist
E10	Incorrect calendar format
E11	Incorrect camera settings
E14	Incorrect trigger source interface
	Incorrect data ID (not available from current inspection)
E15	Inconsistent operating and configured trigger IDs
E17	System busy, cannot respond
E18	Incorrect numeric content

8.2.3 Private Code Custom Output Data Format

When outputting result data using private code, you can also define the output data format.

- In the Main window, click **System > Communication Setting > Protocol Setting > RS232 or RS485 > Detail Setup**.

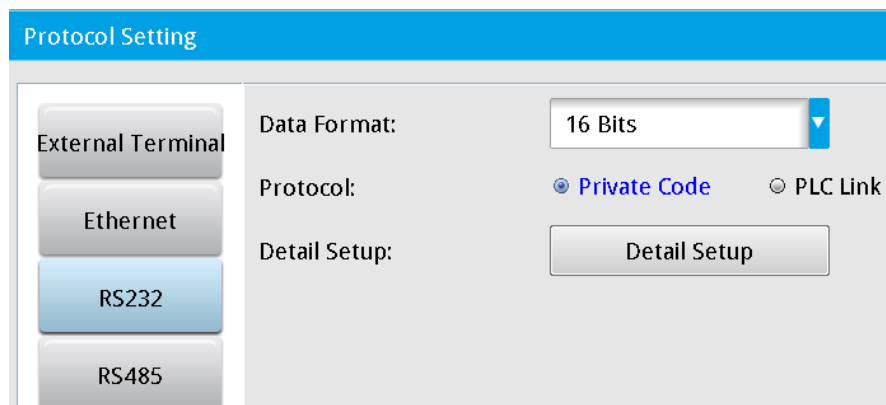

- This opens the **Custom private code** dialog box. The factory setting for **Private Code Format** is **Default** in default condition, and the result output format uses the standard method described in Section 8.2.1.

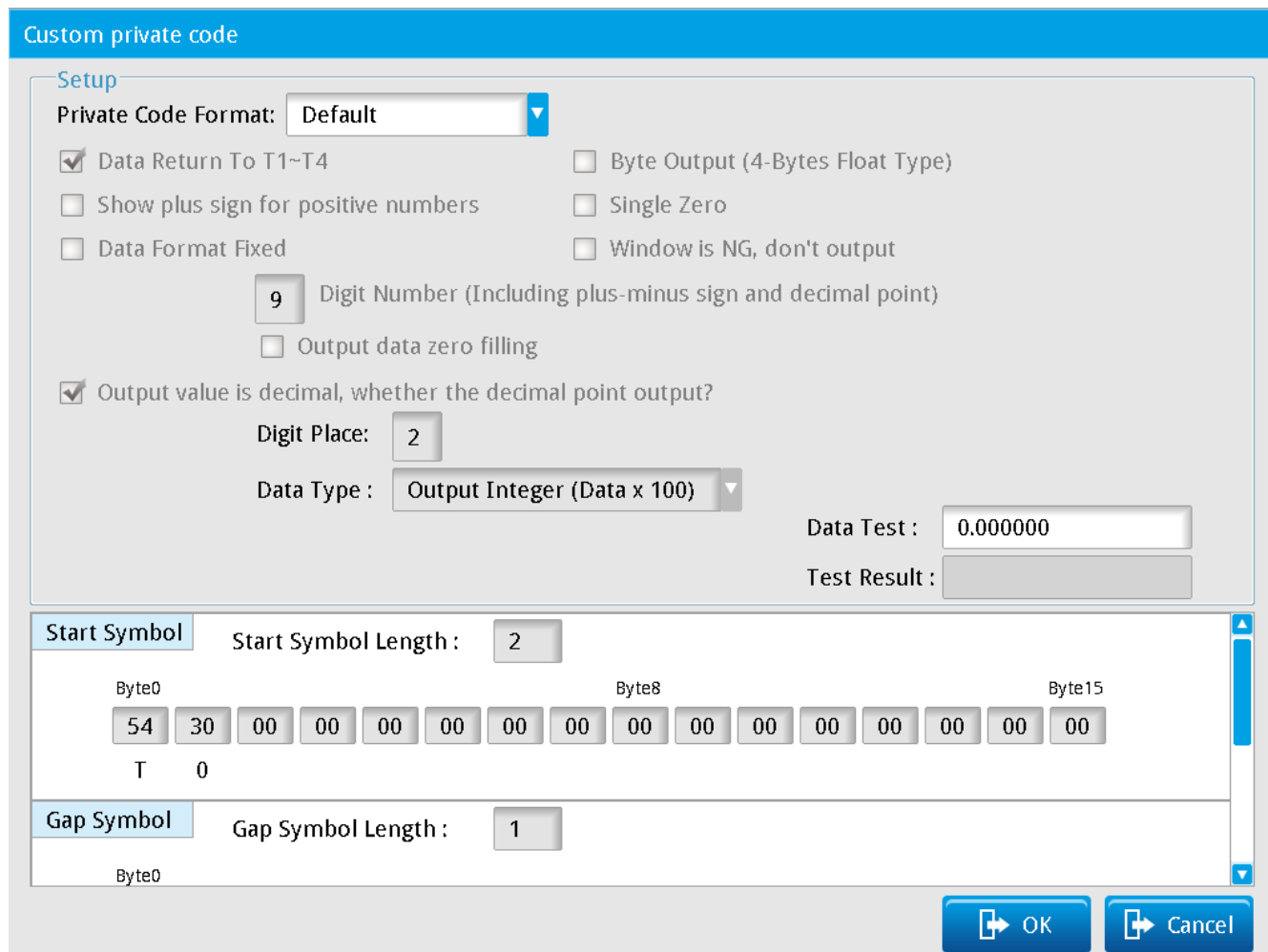

- Selecting **Custom private code** for **Private Code Format** opens the configuration items shown below.

Custom private code

Setup

Private Code Format: Custom private code

Data Return To T1~T4

Show plus sign for positive numbers

Data Format Fixed

Byte Output (4-Bytes Float Type)

Single Zero

Window is NG, don't output

9 Digit Number (Including plus-minus sign and decimal point)

Output data zero filling

Output value is decimal, whether the decimal point output?

Digit Place: 2

Data Type: Output Integer (Data x 100)

Data Test: 0.000000

Test Result: 0.00

- **Data Return T1–T4:** select to specify that result data is transmitted according to the camera ID. After T1–T4 , the system sends the result data. Clear this check box to specify that the system directly sends the result data according to the method that you select; see the following picture.

Custom private code

Setup

Private Code Format: Custom private code

Data Return To T1~T4

Show plus sign for positive numbers

Data Format Fixed

- **Show plus sign for positive numbers:** select to specify that a plus sign is added to all positive result data. When the private code sends negative data, the negative sign is always added before the value, regardless of this option.

Custom private code

Setup

Private Code Format: Custom private code

Data Return To T1~T4

Show plus sign for positive numbers

Data Format Fixed

- **Data Format Fixed:** select to specify that data is output in fixed decimal places.

For example, the original output value is 123.00; selecting this option outputs the data as 000123.00.

Data Format Fixed
 Window is NG, don't output
 Digit Number (Including plus-minus sign and decimal point):
 Output data zero filling

- **Output value is decimal, whether the decimal point output?:** select to specify that the output decimal place is based on the number you enter in **Digit Place**.

For example, the original value on the lower right is 123.000000 and the actual output is 123.000.

Output value is decimal, whether the decimal point output?
 Digit Place:
 Data Type:
 Data Test:
 Test Result:

- **Output value is decimal, whether the decimal point output?:** clear this check box to specify that the output result is generated after multiplying by the value you enter for **Data Type**.

For example, the original value on the lower right is 123.000000 and you select **Output Integer (Data x 100)** for **Data Type**, then the actual output 12300.

Output value is decimal, whether the decimal point output?
 Digit Place:
 Data Type:
 Data Test:
 Test Result:

- Custom output result string format

The output format is Start Symbol + Result1 + Gap Symbol + Result2 + Gap Symbol...+ Stop Symbol.

- ◆ **Start Symbol:** first determine the **Start Symbol Length**. As shown in the following picture, setting Start Symbol Length to 3 means that the start symbol is three characters. Refer to the ASCII table in Section 8.6 to for the hexadecimal values corresponding to the ASCII characters.

Start Symbol Start Symbol Length:
 Byte0: 54 30 00 00 00 00 00 00 00 00 00 00 00 00 00 00
 T 0 NUL
Gap Symbol Gap Symbol Length:
 Byte0

8.3 PLC Automatic Linking Communication Mode

In PLC automatic linking communication, the system automatically writes the inspection result from the DMV2000 to the PLC register, and the PLC programmer can access the data from the PLC register without having to decode the data format.

- Configure protocol settings in the DMV2000 Main window by clicking **System > Communication Setting > Device Setting > RS232 or RS485**.

The screenshot shows the 'Device Setting' window with the 'RS232' option selected. The settings are as follows:

Setting	Value
Baud Rate	115200
Stop Bit	1
Parity Bit	None
Data Bit	8-bit

- Enter the DMV2000 host station number in RS485 ID.

The screenshot shows the 'Device Setting' window with the 'RS485' option selected. The settings are as follows:

Setting	Value
Baud Rate	115200
Stop Bit	1
Parity Bit	None
Data Bit	8-bit
ID	1

- In the Main window, click **System > Communication Setting > Protocol Setting > RS232** or **RS485** and then select **PLC Link** for **Protocol**. The settings for PLC Link appear in the **Protocol Setting** dialog box.

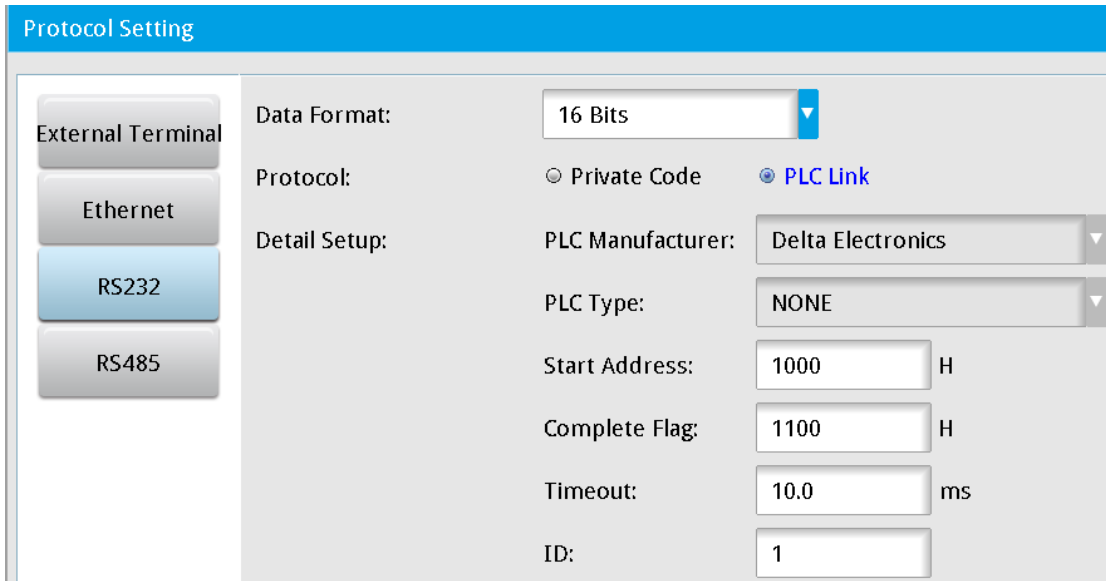

- ◆ **Data Format: 16 Bits** or **32 Bits**. When the actual output data values exceeds the range -32,767 to 32,768, select 32 Bits (double word) to prevent overflow.
- ◆ **PLC Manufacturer**: currently supports Delta PLC only.
- ◆ **PLC Type**: specifies the type of PLC. Different PLCs from different manufacturers vary in the supported communication protocols.
- ◆ **Start Address**: specifies the PLC data start register. Setting this to 1000 means start saving from the D1000 register address.
- ◆ **Complete Flag**: after the DMV2000 writes the data to the PLC's Start Address register, the DMV2000 writes 1 to the Complete Flag register, and the PLC can then determine whether the data is written successfully.
After the PLC confirms the data write access (i.e., D1100 = 1), you must manually set the Complete Flag register to 0 for the next write access.
- ◆ **Timeout**: specifies the time elapsed before a communication timeout. After the DMV2000 sends communication commands, but does not receive a PLC response in the set time, the system enters the timeout condition.
- ◆ **ID**: specifies the PLC station number to link.

- The configuration method for RS485 is identical to that for RS232.

The screenshot shows a software interface titled "Protocol Setting". On the left, there is a vertical sidebar with four buttons: "External Terminal", "Ethernet", "RS232", and "RS485". The "RS485" button is highlighted in blue. The main area of the window is divided into two columns. The left column contains labels for the settings: "Data Format:", "Protocol:", and "Detail Setup:". The right column contains the corresponding input fields and controls. "Data Format:" is a dropdown menu set to "16 Bits". "Protocol:" has two radio buttons: "Private Code" (unselected) and "PLC Link" (selected). "Detail Setup:" includes several fields: "PLC Manufacturer:" is a dropdown menu set to "Delta Electronics"; "PLC Type:" is a dropdown menu set to "NONE"; "Start Address:" is a text box with "1000" and a unit "H"; "Complete Flag:" is a text box with "1100" and a unit "H"; "Timeout:" is a text box with "10.0" and a unit "ms"; and "ID:" is a text box with "1".

Remark This function currently supports only the RS232 and RS485 communication interfaces.

8.4 Modbus Master Mode Communication Mode

When you select the Modbus communication mode, the system actively sends the data as the Modbus master.

- In the DMV2000 Main window, click **System > Communication Setting > Protocol Setting > RS232** or **RS485** and select **Modbus**.

If you need to send the command in ASCII format, select **Modbus ASCII** for **Modbus Type** as shown in the following picture

The screenshot shows the 'Protocol Setting' window. On the left, there are four buttons: 'External Terminal', 'Ethernet', 'RS232', and 'RS485'. The 'RS232' button is highlighted. The main area contains the following settings:

- Data Format: 16 Bits
- Protocol: Private Code, PLC Link, Modbus
- Detail Setup:
 - ModBus Type: Modbus ASCII
 - Start Address: 1000 H
 - ID: 1

- If you need to send the command in TCP format, select **Modbus Tcp** for **Modbus Type** as shown in the following picture.

The screenshot shows the 'Protocol Setting' window. On the left, there are four buttons: 'External Terminal', 'Ethernet', 'RS232', and 'RS485'. The 'RS232' button is highlighted. The main area contains the following settings:

- Data Format: 16 Bits
- Protocol: Private Code, PLC Link, Modbus
- Detail Setup:
 - ModBus Type: Modbus Tcp
 - Start Address: 1000 H
 - ID: 1

- When you select Modbus, you also must select **RS232** and **RS485** in **Result Output > Device Choose**. Then the system starts sending data and commands to the mechanical arm or the other manufacturer's PLC.

The screenshot shows the 'Device Choose' window with the following options:

- RS232
- RS485
- FTP
- Ethernet
- SD Card
- SD Card 2
- External Terminal

8.4.1 Modbus ASCII Master Mode Command Table:

When the inspection is completed, the DMV2000 sends the data in Modbus ASCII type.

➤ **Write 06 Single Entry Write Command Description:** (sends the correctly written data string as is)

Output format

:	01	06	1000	0001	E8	CR	LF
Header	Node ID	Function code (write)	Function address	Write data	Parity	Suffix	

Send format

:	01	06	1000	0001	E8	CR	LF
Header	Node ID	Function code (write)	Function address	Write data	Parity	Suffix	

➤ **Write 10 Multiple Entry Write Command Description:** (maximum length of six entries)

Output format

:	01	10	1070	0002	04	0060	0015	F4	CR	LF
Header	Node ID	Function code	Function address	Writes	Byte count	Data 1	Data 2	Parity	Suffix	

Send format

:	01	10	1070	0002	6E	CR	LF
Header	Node ID	Function code	Function address	Writes	Parity	Suffix	

Parity check:

Sum two-by-two, then take the two's complement of the last two digits (add in hexadecimal without the header).

For example: 0110107000020400600015 F4 CR LF

$01+10+10+70+00+02+04+00+60+00+15 = 10C$ (take the last 2 codes 0C)

Calculate the one's complement = $FF - 0C = F3$ (one's complement is FF minus the value)

Calculate the two's complement = $F3 + 1 = F4$ (two's complement is the sum of one's complement and 1).

8.4.2 Modbus TCP Master Mode Command Table:

When the inspection is completed, the DMV2000 sends the data in Modbus TCP type.

- ⊙ **Write 06 Single Entry Write Command Description:** (sends the correctly written data string as is)

Output format

000000000000	01	06	1000	0001
	Node ID	Function code(write)	Function address	Writes

Send format

000000000000	01	06	1000	0001
	Node ID	Function code(write)	Function address	Writes

- **Write 10 Multiple Entry Write Command Description:** (maximum length of six entries)

Output format

000000000000	01	10	1070	0002	04	0060	0015
	Node ID	Function code(writes)	Function address	Writes	Byte count	Data 1	Data2

Send format

000000000000	01	10	1070	0002
	Node ID	Function code(writes)	Function address	Writes

8.5 Modbus Communication Mode

When you select the Modbus communication mode, the system acts in Modbus slave mode.

- On the DMV2000 Main window, click **System > Communication Setting > Protocol Setting > RS232** or **RS485** and then select **Private Code**.

When the output data for read access is in 32-bit format, select **32 Bits** for **Data Format**.

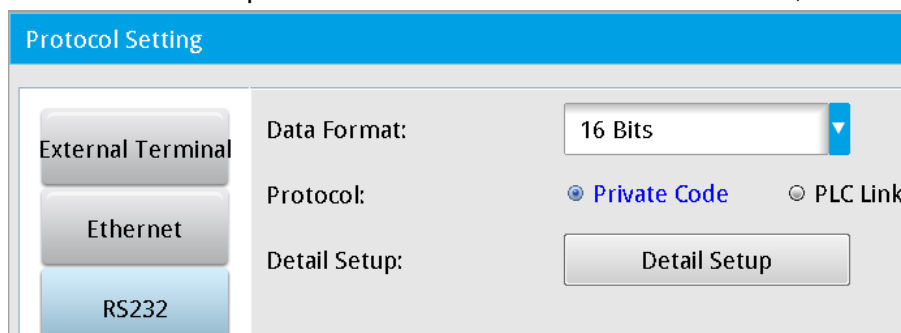

- When you select **Private Code**, the system automatically sends out the data using the Private Code method after completing an inspection. Therefore, you must clear the **RS232** and **RS485** check boxes in **Result Output > Device Choose**. The system stops sending data using the private code method and switches to the Modbus method and waits to receive commands.

Device Choose

<input type="checkbox"/> RS232	<input type="checkbox"/> RS485	<input type="checkbox"/> FTP
<input type="checkbox"/> Ethernet	<input type="checkbox"/> SD Card	<input type="checkbox"/> SD Card 2
<input type="checkbox"/> External Terminal		

8.5.1 Slave Mode Command Table: (Modbus Communication Format)

Only ASCII mode is supported. Refer to the ASCII table in Section 8.6 for ASCII to hexadecimal conversions.

R indicates support for Read commands (03H code; maximum 64 entries).

W indicates support for Write commands (write single entry: 06H code; write multiple entries: 10H code; maximum 6 entries).

- **Read 03 Read Command Description:** (read single or multiple data entries controlled by the **Byte** parameter)

Output format

:	01	03	1010	0002	DA	<input type="checkbox"/> CR	<input type="checkbox"/> LF
Header	Node ID	Function code (read)	Function address	Data ID	Parity	Suffix	

Return format

:	01	03	04	0010	0015	D8	<input type="checkbox"/> CR	<input type="checkbox"/> LF
Header	Node ID	Function code (read)	Number of entries (Byte)	Result 1	Result 2	Parity	Suffix	

- **Write 06 Single Entry Write Command Description:** (returns the correctly written data string as is)

Output format

:	01	06	1000	0001	E8	<input type="checkbox"/> CR	<input type="checkbox"/> LF
Header	Node ID	Function code (write)	Function address	Write data	Parity	Suffix	

Return format

:	01	06	1000	0001	E8	<input type="checkbox"/> CR	<input type="checkbox"/> LF
---	----	----	------	------	----	-----------------------------	-----------------------------

Header	Node ID	Function code (write)	Function address	Write data	Parity	Suffix
--------	---------	-----------------------	------------------	------------	--------	--------

➤ **Write 10 Multiple Entry Write Command Description:** (maximum length of six entries)

Output format

:	01	10	1070	0002	04	0060	0015	F4	<input type="checkbox"/> CR	<input type="checkbox"/> LF
Header	Node ID	Function code	Function address	Writes	Byte count	Data 1	Data 2	Parity	Suffix	

Return format

:	01	10	1070	0002	6D	<input type="checkbox"/> CR	<input type="checkbox"/> LF
Header	Node ID	Function code	Function address	Writes	Parity	Suffix	

Parity check:

Sum two-by-two, then take the two's complement of the last two digits (add in hexadecimal without the header).

For example: 0110107000020400600015 F4 CR LF

01+10+10+70+00+02+04+00+60+00+15 = 10C (take the last 2 codes 0C)

Calculate the one's complement = FF - 0C = F3 (one's complement is FF minus the value).

Calculate the two's complement = F3 + 1 = F4 (two's complement is the sum of one's complement and 1)

◆ **Modbus Communication Address Table**

Position	Function code supported	Name	Description	Permission	
				Run	Edit
1000H(W)	(06H)	Trigger 1 action	Trigger if Data 1 is written	○	
1001H(W)	(06H)	Trigger 2 action	Trigger if Data 1 is written	○	
1002H(W)	(06H)	Trigger 3 action	Trigger if Data 1 is written	○	
1003H(W)	(06H)	Trigger 4 action	Trigger if Data 1 is written	○	
1010H–104FH(R)	(03H)	Output data (total 64 entries)	(refer to the following for description on output data)	○	
1050H(W)	(06H)	Switch to Run mode	Trigger if Data 1 is written		○
1051H(W)	(06H)	Switch to Edit mode	Trigger if Data 1 is written	○	
1060H(R/W)	(03H,06H)	Read/switch program ID	0–999(0–31 internal memory; 32–999 memory card)	○	○
1062H(R/W)	(03H,06H)	Read/switch window ID	1000 Start	○	

Chapter 8 Serial Communication

1070H(W)	(10H)	Read upper/lower (window)	Data ID to read	O	
1071H(W)			Window ID to read		
1072H(R)	(03H)		Read upper limit (low word)		
1073H(R)	(03H)		Read upper limit (high word)		
1074H(R)	(03H)		Read lower limit (low word)		
1075H(R)	(03H)		Read lower limit (high word)		
1077H(W)	(10H)	Write upper/lower (window)	Data ID to write	O	
1078H(W)			Window ID to write		
1079H(W)			Write upper limit (low word)		
107AH(W)			Write upper limit (high word)		
107BH(W)			Write lower limit (low word)		
107CH(W)			Write lower limit (high word)		
1090H(R/W)	(03H,06H,10H)	Read/set date and time	Date (Year) (00–99)	O	O
1091H(R/W)	(03H,06H,10H)		Date (Month) (01–12)		
1092H(R/W)	(03H,06H,10H)		Date (Day) (01–31)		
1093H(R/W)	(03H,06H,10H)		Time (hour) (00–23)		
1094H(R/W)	(03H,06H,10H)		Time (minute) (00–59)		
1095H(R/W)	(03H,06H,10H)		Time (second) (00–59)		
10A0H(W)	(10H)	Set camera shutter speed	Camera ID (1–2)	O	
10A1H(W)			Shutter speed (1–15)		
10A2H(W)	(10H)	Set camera gain and brightness	Camera ID (1–2)	O	
10A3H(W)			Gain (00–100)		
10A4H(W)			Luminance (00–100)		
10A5H(W)	(10H)	Password Type	0: old password 1: new password	O	O
10B0H(W)	(06H)	Enable input trigger	Trigger if Data 1 is written	O	
10B1H(W)	(06H)	Disable input trigger	Trigger if Data 1 is written	O	
10B2H(W)	(06H)	Save all program setting	Trigger if Data 1 is written		O
10B3H(W)	(06H)	Capture image	Trigger if Data 1 is written	O	O
10B4H(W)	(06H)	Clear statistics	Trigger if Data 1 is written	O	O

10B5H(W)	(06H)	System reset	Trigger if Data 1 is written	O	
10F0H(W)	(10H)	Read window parameter	Window ID (0–127)	O	O
10F1H(W)			Item number (0–20)		
10F2H(R)	(03H)		Window parameter (low word)		
10F3H(R)	(03H)		Window Parameter (high word)		
10F7H(W)	(10H)	Write window parameter	Window ID (0–127)	O	O
10F8H(W)			Item number (0–20)		
10F9H(W)			Window parameter (low word)		
10FAH(W)			Window parameter (high word)		

Common Error Message Codes

➤ Error Handling (W): return string

- :01860178 CR LF : function code unsupported
- :01860277 CR LF : write address error
- :01860673 CR LF : unable to execute (system not Ready)
- :01860970 CR LF : parity check failed
- :01860C6D CR LF : illegal Modbus command length
- :01860D6C CR LF : illegal Modbus command length
- :01860E6B CR LF : Modbus command contains illegal character(s)

Error Handling (R): Return string

- :0183017B CR LF : function code unsupported
- :0183027A CR LF : read address error
- :01830676 CR LF : unable to execute (system not Ready)
- :01830973 CR LF : parity check failed
- :01830C70 CR LF : illegal Modbus command length
- :01830D6F CR LF : illegal Modbus command length
- :01830E6E CR LF : Modbus command contains illegal character(s)

1) Trigger1 Action 1000H (W) (Run Mode enabled)

Input string: 010610000001 E8 Return string: 010610000001 E8

- **Description:** after writing a "1", the switch is successful if the string returned is identical.

After triggering in Modbus mode, the system does not automatically send results after completing an inspection. The system saves the inspection result in the 1010H–104H register. When Ready turns ON again, send the Read command to get the inspection results.

- **Error Handling:** return string

- :01860376 : incorrect content or length of write data (only one entry is allowed).
- :01860475 : unable to execute (system permits incorrect operating status and trigger source interface).

2) Trigger2 Action 1000H (W) (Run Mode enabled)

Input string: 010610010001 E7 Return string: 010610010001 E7

- **Description:** after writing a "1", the switch is successful if the string returned is identical.

After triggering in Modbus mode, the system does not automatically send results after completing an inspection. The system saves the inspection result in the 1010H–104H register. When Ready turns ON again, send the Read command to get the inspection results.

- **Error Handling:** return string

- :01860376 : incorrect content or length of write data (only one entry is allowed).
- :01860475 : unable to execute (system permits incorrect operating status and trigger source interface).

3) Trigger3 Action 1000H (W) (Run Mode enabled)

Input string: 010610020001 E6 Return string: 010610020001 E6

- **Description:** after writing a "1", the switch is successful if the string returned is identical.

After triggering in Modbus mode, the system does not automatically send results after completing an inspection. The system saves the inspection result in the 1010H–104H register. When Ready turns ON again, send the Read command to get the inspection results.

- **Error Handling:** return string

- :01860376 : incorrect content or length of write data (only one entry is allowed).
- :01860475 : unable to execute (system permits incorrect operating status and trigger source interface).

4) Trigger4 Action 1000H (W) (Run Mode enabled)

Input string: 010610030001 E5 Return string: 010610030001 E5

- **Description:** after writing a "1", the switch is successful if the string returned is identical.
After triggering in Modbus mode, the system does not automatically send results after completing an inspection. The system saves the inspection result in the 1010H–104H register. When Ready turns ON again, send the Read command to get the inspection results.
- **Error Handling:** return string
 - :01860376 : incorrect content or length of write data (only one entry is allowed).
 - :01860475 : unable to execute (system permits incorrect operating status and trigger source interface).

5) Output Data 1010H–104FH (R) (Run Mode enabled)

Output the previous inspection result if there is no inspection program to run.

16 Bits (Word) Data Mode: if two data entries need to be returned (50,000, 300)

Input string: 010310100002 DA Return string: 010304C350012CB8

- **Description:** 50,000 is C350 (hex) and 300 is 12C (hex); B8 is the parity code.

32 Bits (Double Word) Data Mode: if two data entries need to be returned (400,000, 300)

Input string: 010310100004 D8 Return string: 01030800061A800000012C27

- **Description:** 400,000 is 61A80 (hex) and 300 is 12C (hex); 27 is the parity code.
- If the output value exceeds 65535, set the data format to **32bits** to prevent writing to the wrong register.

Judge (0/1) Data Format: (return bit 2=0, bit 3=1, bit 4=1 when needed)

Input string: 010310100001 DB Return string: 0103020018E2

- ⊙ **Description:** 0018 (hex) is 0000000000011000 (binary)
- ◆ Judge output format is **16bits** regardless of the setting (16bits or 32bits).
For example: return data is 400,000 and a set of Judge values of bit 2=0, bit 3=1, bit 4=1.
Then read three entries of string length: 010310100003 D9 (one entry of DW data and one entry of W Judge content).
System returns: 01030600061A8000183E
- ⊙ **Error Handling:** return string
 - :01830478 : unable to execute (system permits incorrect operating status).

6) Switch to Run Mode 1050H (W) (Edit Mode enabled)

Input string: 010610500001 5A Return string: 010610500001 5A

- ⊙ **Description:** after writing a "1", the switch is successful if the string returned is identical.
- ⊙ **Error Handling:** return string
 - :01860376 : incorrect content or length of write data (only one entry is allowed).
 - :01860475 : unable to execute (system permits incorrect operating status).
 - :01860B70 : program ID does not exist (or program ID not set).

7) Switch to Edit mode 1051H (W) (Run Mode enabled)

Input string: 010610510001 97 Return string: 010610510001 97

- ⊙ **Description:** after writing a "1", the switch is successful if the string returned is identical.
- ⊙ **Error Handling:** return string
 - :01860376 : incorrect content or length of write data (only one entry is allowed).
 - :01860475 : unable to execute (system permits incorrect operating status).

8) Read/Switch Program ID 1060H (R/W) (Run Mode and Edit Mode enabled)

Program ID 0–31 saved on internal memory and 32–999 on SD card.

Read Program ID: (returns the current program ID 10)

Input string: 010310600001 8B Return string: 010302000A F0

- ⊙ **Description:** 10 (dec) is 000A (hex).

Switch Program ID: (switch program ID to 20)

Input string: 010610600014 75 Return string: 010610600014 75

- ⊙ **Description:** 20 (dec) is 0014 (hex).
After writing the value, the switch is successful if the string returned is identical.

- ⊙ **Error Handling:** return string
 - :01830379 : incorrect content or length of read data (only one entry is allowed).
 - :01860376 : incorrect write data length (only one entry is allowed); program ID does not exist (or not set).
 - :01860B6E : unable to execute (current page unsupported).

9) Read/Switch Window ID 1062H (R/W) (Run Mode enabled)**Read Window ID:** (returns current window ID 50)Input string: 010310620001 89 Return string: 0103020032 C8

- ⊙ **Description:** 50 (dec) is 0032 (hex).

Switch Window ID: (switch window ID to 30)Input string: 01061062001E 69 Return string: 01061062001E 69

- ⊙ **Description:** 30 (dec) is 001E (hex).

After writing the value, the switch is successful if the string returned is identical.

- ⊙ **Error Handling:** return string

- :01830379 : incorrect content or length of read data (only one entry is allowed).
- :01830478 : unable to execute (system permits incorrect operating status).
- :01860376 : incorrect content or length of write data (only one entry is allowed); window ID does not exist (or not set).
- :01860475 : unable to execute (system permits incorrect operating status).

10) Read Upper/Lower (Window) 1070H–1075H (Run Mode enabled)

The following six registers are required to read the upper and lower limits for the Window.

1070H (R/W): data item number to read or write

1071H (R/W): window ID to read or write

1072H (R): upper read limit (low word)

1073H (R): upper read limit (high word)

1074H (R): lower read limit (low word)

1075H (R): lower read limit (high word)

- ◆ The data to be accessed, Data Item Number 1070H and Window ID 1071H, are first written to the register, then the required data can be accessed from the addresses 1072H–1075H.

Read Upper/Lower Limit: (i.e., data ID =2, window ID = 5, upper and lower limits are 500,000 and 300)First enter string: 0110107000020400020005 62 Return string: 011010700002 6D

- ⊙ **Description:** entering two words is represented by 0002.

Two words consist of four bytes. Enter 04.

Decimal 2 is 0002 (hex).

Decimal 5 is 0005 (hex).

Then enter the read string: 010310720004 76 Return string: 0103080007A1200000012C FF

- ◎ **Description:** The system now reads four words, which consist of eight bytes. Enter 08.
Decimal 500,000 is 0007A120 (hex).
300 (dec) is 0000012C (hex).
Upper and lower limits are fixed DW (32 bit) format.

- ◎ **Error Handling:** return string
 - :01830379 : incorrect content or length of read data.
 - :01830478 : unable to execute (system permits incorrect operating status and no data item number or window ID).
 - :01860376 : incorrect content or length of write data.
 - :01860475 : unable to execute (system permits incorrect operating status and no window ID).
 - :01860B6E : unable to execute (data item number does not exist).

11) Write Upper/Lower (Window) 1077H–107CH (Run Mode enabled)

The following six registers are required to write the upper and lower limits of the Window. Using multi-write commands, you can simultaneously write the 6 entries to the register according to the following order to change the upper and lower limits.

1077H (W): data item number written

1078H (W): window ID written

1079H (W): upper limit written (low word)

107AH (W): upper limit written (high word)

107BH (W): lower limit written (low word)

107CH (W): lower limit written (high word)

Write Upper/Lower: (i.e., data ID =6, window ID = 20, upper and lower limits are 600,000 and 400)

Input string: 0110107700060C00060014000927C000000190 BB

Return string: 011010770006 62

- ◎ **Description:** Entering six words is represented by 0006.
Six words consist of 12 bytes. Enter 0C.
Decimal 6 is 0006 (hex).
Decimal 20 is 0014 (hex).
Decimal 600,000 is 000927C0 (hex).
Decimal 400 is 00000190 (hex).
Upper and lower limits are fixed DW (32 bit) format.

- ◎ **Error Handling:** return string
 - :01860475 : Unable to execute (system permits incorrect operating status and no window ID).
 - :01860B6E : Unable to execute (data item number does not exist).

12) Read/Set Date and Time 1090H–1095H (Run Mode and Edit Mode enabled)

1090H (R/W): Date (Year) (00–99; do not need to add the 20 from the yyyy format)

1091H (R/W): Date (Month) (01–12)

1092H (R/W): Date (Day) (01–31)

1093H (R/W): Time (Hour) (00–23)

1094H (R/W): Time (Minute) (00–59)

1095H (R/W): Time (Second) (00–59)

Read Time/Date: (for example, the content to read is 2011/07/22 08:30:58)

Input string: 010310900006 56

Return string: 01030C000B000700160008001E003A 68

⊙ **Description:** 11(dec) is 000B (hex).

Decimal 07 is 0007 (hex).

Decimal 22 is 0016 (hex).

Decimal 08 is 0008 (hex).

Decimal 30 is 001E (hex).

Decimal 58 is 003A (hex).

Write Time/Date: (for example, the content to write is 2011/08/25 12:30:40)

First enter string 0110109000060C000B00080019000C001E0028 BF

Return string: 011000900006 59

⊙ **Description:** 11 (dec) is 000B (hex).

Decimal 08 is 0008 (hex).

Decimal 25 is 0019 (hex).

Decimal 12 is 000C (hex).

Decimal 30 is 001E (hex).

Decimal 40 is 0028 (hex).

In addition to multi-writes for the date/time, a single write 06 is also supported.

⊙ **Error Handling:** return string

➤ :01860376 : incorrect content or length of write data.

13) Set Camera Shutter Speed 10A0H–10A1H (Run Mode enabled)

The following two registers are required to write Camera shutter speed. With multi-writes, both register writes can be issued at the same time.

10A0H (W): Camera ID (1–2)

10A1H (W): Shutter Speed (1–20)

01= 6000ms	05= 2000ms	09= 33.33ms	13= 4.17ms	17= 0.2ms
02= 5000ms	06= 1000ms	10= 16.67ms	14= 2ms	18= 0.1ms
03= 4000ms	07= 500ms	11= 10ms	15= 1ms	19= 0.05ms
04= 3000ms	08= 66.67ms	12= 8.33ms	16= 0.5ms	20= 0.025ms

Write Settings: (for example, set Camera2 shutter speed to 0.5 ms)

Input string: 011610A00002040002000A 2D

Return string: 011610A00002 3D

⊙ **Description:** entering two words is represented by 0002.

Two words consist of four bytes. Enter 04.

2 (dec) is 0002 (hex).

Decimal 10 is 000A (hex).

⊙ **Error Handling:** return string

➤ :01860475 : unable to execute (system permits incorrect operating status and no cameras).

14) Set Camera Gain and Luminance 10A2H–10A4H (Run Mode enabled)

The following three registers are required to write Gain and brightness. With multi-writes, the three register writes can be issued at the same time.

10A2H (W): Camera ID (1–2)

10A3H (W): Gain (00–100; larger values generate brighter images)

10A4H (W): Luminance (00–100; larger values generate brighter images)

Write Settings: (for example, set Camera2 Gain and Luminance to 50 and 70, respectively)

Input string: 011010A2000306000200320046 BA

Return string: 011010A20003 3A

⊙ **Description:** 2 (dec) is 0002 (hex).

Decimal 50 is 0032 (hex).

Decimal 70 is 0046 (hex).

⊙ **Error Handling:** return string

➤ :01860475 : unable to execute (system permits incorrect operating status and no cameras).

15) Change Password 10A5H–10ADH (Run Mode and Edit Mode enabled)

The following registers are required to change the password. Multi-write commands are used. You must enter a command according to the specific password type to confirm the old password before entering a command to change the password.

10A5H (W): password type (two codes)

10A6H–10AD (W): enter password (4–16 codes according to password length)

Write Settings: (for example, change the password from 1234 to 5678)

Input string: 011010A5000306000041424344 27

011010A5000306000145464748 16

Return string: 011010A50003 36

- ⊙ **Description:** according to the ASCII conversion table, the numeric value 1234 converts to **31323334**. According to the ASCII conversion table, the numeric value 5678 converts to **35363738**.
- ⊙ **Error Handling:** return string
 - :01860376 : incorrect content or length of write data.
 - :01860772 : unable to execute (old password input error).

HEX	ASCII	HEX	ASCII	HEX	ASCII
20	SPACE	41	A	61	a
21	!	42	B	62	b
25	%	43	C	63	c
28	(44	D	64	d
29)	45	E	65	e
2B	+	46	F	66	f
2D	-	47	G	67	g
2E	.	48	H	68	h
30	0	49	I	69	i
31	1	4A	J	6A	j
32	2	4B	K	6B	k
33	3	4C	L	6C	l
34	4	4D	M	6D	m
35	5	4E	N	6E	n
36	6	4F	O	6F	o
37	7	50	P	70	p
38	8	51	Q	71	q
39	9	52	R	72	r
3D	=	53	S	73	s
5B		54	T	74	t

5D		55	U	75	u
5F	_	56	V	76	v
		57	W	77	w
		58	X	78	s
		59	Y	79	y
		5A	Z	7A	z

16) Enable Trigger Input 10B0H (W) (Run Mode enabled)

Input string: 010610B00001 38 Return string: 010610B00001 38

- ⊙ **Description:** after writing the numeric value "1", the switch is successful if the string returned is identical.
- ⊙ **Error Handling:** return string
 - 01860376 : incorrect content or length of write data.
 - 01860475 : unable to execute (system permits incorrect operating status).

17) Disable Trigger Input 10B1H (W) (Run Mode enabled)

Input string: 010610B10001 37 Return string: 010610B10001 37

- ⊙ **Description:** after writing the numeric value "1", the switch is successful if the string returned is identical.
- ⊙ **Error Handling:** Return string
 - :01860376 : incorrect content or length of write data.
 - :01860475 : unable to execute (system permits incorrect operating status).

18) Save All Program Setting 10B2H (W) (Edit Mode enabled)

Input string: 010610B20001 36 Return string: 010610B20001 36

- ⊙ **Description:** after writing the numeric value "1", saving the settings is successful if the string returned is identical.
- ⊙ **Error Handling:** Return string
 - :01860376 : incorrect content or length of write data.
 - :01860475 : unable to execute (system permits incorrect operating status).

19) Capture Image 10B3H (W) (Run Mode and Edit Mode enabled)

Input string: 010610B30001 35 Return string: 010610B30001 35

- ⊙ **Description:** after writing the numeric value "1", the image capture is successful if the string returned is identical.
- ⊙ **Error Handling:** return string
 - :01860376 : incorrect content or length of write data.

20) Clear Statistics 10B4H (W) (Run Mode and Edit Mode enabled)

Input string: 010610B40001 34 Return string: 010610B40001 34

- ⊙ **Description:** after writing the numeric value "1", the statistics data is successfully cleared if the string returned is identical.
- ⊙ **Error Handling:** return string
 - Please refer to common error message codes.

21) System Reset 10B5H (W) (Run Mode enabled)

Input string: 010610B50001 33 Return string: 010610B50001 33

- ⊙ **Description:** after writing the numeric value "1", the system reset is successful if the string returned is identical.
- ⊙ **Error Handling:** return string
 - Please refer to common error message codes.

22) Read Window Parameter 10F0H–10F1H (W) 10F2H–10F3H (R) (Run Mode enabled)

Use the following four registers to read the Parameter settings.

10F0H (W): item number to read

10F1H (W): window ID to read

10F2H (R): read window parameter (low word)

10F3H (R): read window parameter (high word)

- ◆ The data to be accessed, Data Item Number 10F0H and Window ID 10F1H (please see Table 1), are written to the register, then you can access the required data from the addresses 10F2H–10F3H.

Read Upper/Lower Limit: (for example, read W010, the binary lower limit of Area, which is 50)

First enter string 010610F00001 08 Return string: 010610F00001 08

- ⊙ **Description:** 1 (dec) is 0001 (hex).

First enter string 010610F1000A FE Return string: 010610F1000A FE

- ⊙ **Description:** 10 (dec) is 000A (hex).

Then enter read string: 010310F20002 08

Return string: 01030400320000 C6

- ⊙ **Description:** 50 (dec) is 0032 (hex).

Upper and lower limits are fixed DW (32 bit) data structures.

◎ **Error Handling:** return string

- :01830379 : incorrect content or length of read data.
- :01830478 : unable to execute (system permits incorrect operating status and no window ID or item number).
- :01860475 : unable to execute (system permits incorrect operating status and no item number).
- :01860B6E : unable to execute (window ID does not exist).

23) Write Window Parameter 10F7H–10FAH (W) (Run Mode enabled)

Use the following four registers to write the parameter settings. Through multiple write commands, you can simultaneously write the four sets of numeric values to the register to change the upper and lower limits.

10F7H (W): item number to write

10F8H (W): window ID to write

10F9H (W): write window parameter (low word)

10FAH (W): write window parameter (high word)

Write Upper/Lower: (for example, write W001; the Edge Intensity parameter for Edge Position is 20)

You must write numeric values to 10F7H in order. Select the item number to write, write the window ID to the address 10F8H, and then write the numeric value to configure.

Input string: 011010F70004080002000100140000 C5

Return string: 011010F70004 E4

◎ **Description:** 20 (dec) is 0014 (hex).

Upper and lower limits are fixed DW (32 bit) format.

◎ **Error Handling:** return string

- :01860475 : unable to execute (system permits incorrect operating status and no item number).
- :01860B6E : unable to execute (window ID does not exist).

8.6 ASCII Code Table

The characters in bold are currently used by the DMV (HEX indicates hexadecimal).

HEX	ASCII	HEX	ASCII	HEX	ASCII	HEX	ASCII
0	NUL	20	SPACE	40	@	60	`
1	SOH	21	!	41	A	61	a
2	STX	22	"	42	B	62	b
3	ETX	23	#	43	C	63	c
4	EOT	24	\$	44	D	64	d
5	ENQ	25	%	45	E	65	e
6	ACK	26	&	46	F	66	f
7	BEL	27	'	47	G	67	g
8	BS	28	(48	H	68	h
9	TAB	29)	49	I	69	i
A	LF	2A	*	4A	J	6A	j
B	VT	2B	+	4B	K	6B	k
C	FF	2C	,	4C	L	6C	l
D	CR	2D	-	4D	M	6D	m
E	SO	2E	.	4E	N	6E	n
F	SI	2F	/	4F	O	6F	o
10	DLE	30	0	50	P	70	p
11	DC1	31	1	51	Q	71	q
12	DC2	32	2	52	R	72	r
13	DC3	33	3	53	S	73	s
14	DC4	34	4	54	T	74	t
15	NAK	35	5	55	U	75	u
16	SYN	36	6	56	V	76	v
17	ETB	37	7	57	W	77	w
18	CAN	38	8	58	X	78	x
19	EM	39	9	59	Y	79	y
1A	SUB	3A	:	5A	Z	7A	z
1B	ESC	3B	;	5B	[7B	{
1C	FS	3C	<	5C	\	7C	
1D	GS	3D	=	5D]	7D	}
1E	RS	3E	>	5E	^	7E	~
1F	US	3F	?	5F	_	7F	DEL

8.7 Ethernet Private Code Communication

In private code communication, the system automatically sends the results from the DMV2000 after completing the inspection. After receiving the strings, the DMV2000 generates the required results through decoding according to the defined format, and sends them to the superior controller. Besides transmitting inspection results, private code mode also supports multiple written control commands.

The following section explains the private code communication format configurations through Ethernet.

- Configure the DMV2000 IP Ethernet settings. In the DMV2000 Main window, click **System > Communication Setting > Device Setting > Ethernet**

The screenshot shows the 'Device Setting' window with a blue header. On the left, there is a vertical menu with four buttons: 'External Terminal', 'Ethernet' (highlighted in blue), 'RS232', and 'RS485'. The main area contains the following configuration fields:

IP Version:	<input checked="" type="radio"/> IPv4
IP Address:	192 . 168 . 1 . 2
Subnet Mask:	255 . 255 . 255 . 0
Default Gateway:	192 . 168 . 1 . 1
Port:	502
MAC Address:	D0 : 39 : 72 : 07 : 6D : 94

- ◆ IP Address: enter the IP address for data reception; for example, configure to 192.168.1.3
- ◆ Port: set to 2048

The screenshot shows a 'Protocol Setting' window. On the left, there are four buttons: 'External Terminal', 'Ethernet' (which is highlighted in blue), 'RS232', and 'RS485'. To the right of these buttons, there are two rows of input fields. The first row is labeled 'Port:' and has a single input field containing the number '2048'. The second row is labeled 'IP Address:' and has four input fields containing the numbers '192', '168', '1', and '3' respectively, separated by dots.

After completing each inspection, the system actively returns the following string: T0 + Output data

- **Description:** For example, for integer type data, the data to return is (1234).

The system returns: T001234.00

 **Reference** You can customize the format to determine whether the output data type consists of decimal places and specific decimal lengths. Refer to Section 8.6.3.

8.7.1 Ethernet Private Code Mode Command Table: (DMV2000 Custom Communication Format)

	Function	Input string	Permission	
			Run	Edit
1	Trigger 1 action and output	T1	O	
2	Trigger 2 action and output	T2	O	
3	Trigger 3 action and output	T3		
4	Trigger 4 action and output	T4		
5	Go to Run mode	RN		O
6	Go to Program mode	PG	O	

8.7.2 Ethernet Private Code Mode Commands: (DMV2000 Custom Communication Format)

1) Trigger1 Action and Output Data (Run Mode enabled)

Input string: T1 Return string: T0 + Output data

- ⦿ **Description:** for integer type data, the data to return is (1234).

Return: T001234.00

 **Reference** You can customize the format to determine whether the output data type consists of decimal places and specific decimal lengths. Refer to Section 8.6.3.

2) Trigger2 Action and Output Data (Run Mode enabled)

Input string: T2 Return string: T0 + Output data

- ⦿ **Description:** for integer type data, the data to return is (1234).

Return: T001234.00

 **Reference** You can customize the format to determine whether the output data type consists of decimal places and specific decimal lengths. Refer to Section 8.6.3.

3) Trigger3 Action and Output Data (Run Mode enabled)

Input string: T3 Return string: T0 + Output data

- ⦿ **Description:** for integer type data, the data to return is (1234).

Return: T001234.00

 **Reference** You can customize the format to determine whether the output data type consists of decimal places and specific decimal lengths. Refer to Section 8.6.3.

4) Trigger4 Action and Output Data (Run Mode enabled)

Input string: T4 Return string: T0 + Output data

- ⦿ **Description:** for integer type data, the data to return is (1234).

Return: T001234.00

 **Reference** You can customize the format to determine whether the output data type consists of decimal places and specific decimal lengths. Refer to Section 8.6.3.

5) To Run Mode (Edit Mode enabled)

Input string: RN

6) To Edit Mode (Run Mode enabled)

Input string: PG

8.7.3 Ethernet Private Code Custom Output Data Format

When you configure the system to output result data using private code through Ethernet, you can also define the output data format.

- In the DMV2000 Main window, click **System > Communication Setting > Protocol Setting > RS232** or **RS485 > Detail Setup**.

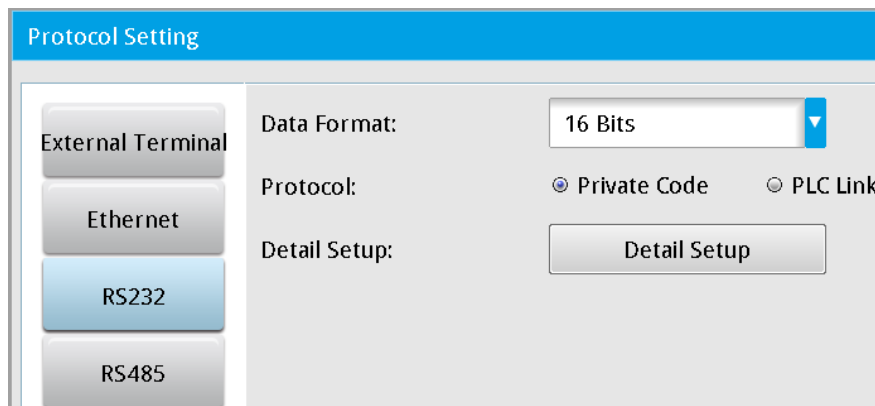

- This displays the **Custom private code** dialog box. The factory setting for **Private Code Format** is **Default**. The following picture shows the default settings for the Private Code Format.

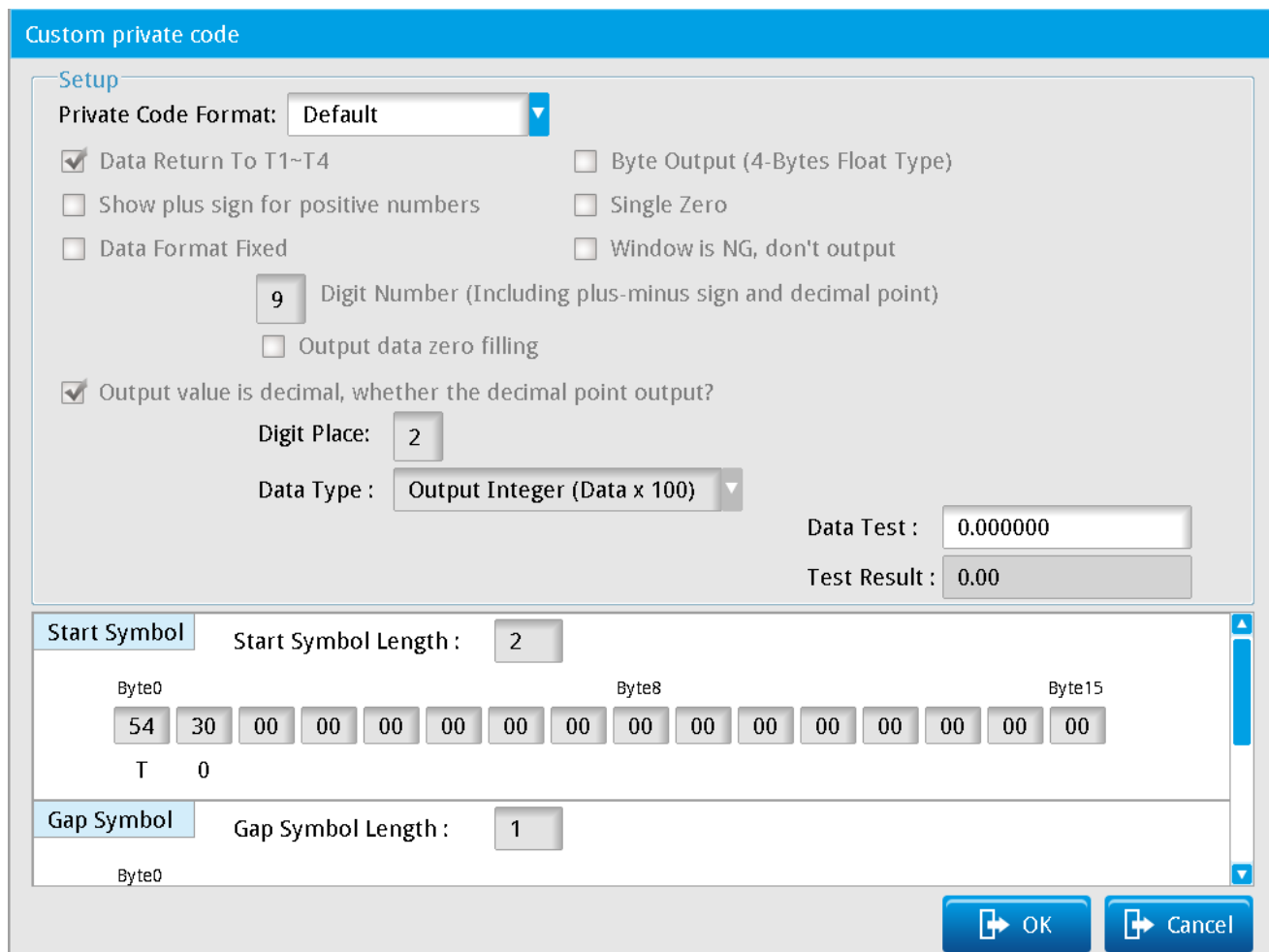

- The following picture shows the settings when you select **Custom private code** for **Private Code Format**.

Custom private code

Setup

Private Code Format: Custom private code

Data Return To T1~T4

Show plus sign for positive numbers

Data Format Fixed

Byte Output (4-Bytes Float Type)

Single Zero

Window is NG, don't output

9 Digit Number (Including plus-minus sign and decimal point)

Output data zero filling

Output value is decimal, whether the decimal point output?

Digit Place: 2

Data Type: Output Integer (Data x 100)

Data Test: 0.000000

Test Result: 0.00

- **Data Return T1–T4:** the option is unavailable when outputting results through Ethernet.

Custom private code

Setup

Private Code Format: Custom private code

Data Return To T1~T4

Show plus sign for positive numbers

Data Format Fixed

- **Show plus sign for positive numbers:** when you select this check box, the system adds a plus sign in front of all positive result data.

When private code mode sends out negative data, the system always adds a negative sign in front of the values regardless of the setting for this check box.

Custom private code

Setup

Private Code Format: Custom private code

Data Return To T1~T4

Show plus sign for positive numbers

Data Format Fixed

- **Data Format Fixed:** when you select this check box, data is output in fixed decimal places. For example, the original output value is 123.00; selecting the following check box outputs the data as 000123.00.

Data Format Fixed
 Window is NG, don't output
 Digit Number (Including plus-minus sign and decimal point)
 Output data zero filling

- **Output value is decimal, whether the decimal point output?:** when you select this check box, the number of decimal places in the output is based on the **Digit Place** (the number of decimal places). For example, the original output value is 123.000000, and the actual output is 123.000.

Output value is decimal, whether the decimal point output?
 Digit Place:
 Data Type : Output Integer (Data x 100) ▾
 Data Test :
 Test Result :

- **Output value is decimal, whether the decimal point output?:** when you clear this check box, the output result is generated after multiplying the value by **Data Type**. For example, the original value is 123.000000 and **Output Integer (Data x 100)** is selected for **Data Type**. The actual output is 12300.

Output value is decimal, whether the decimal point output?
 Digit Place:
 Data Type : Output Integer (Data x 100) ▾
 Data Test :
 Test Result :

- Custom output result string format

The Output format is Start Symbol + Result1 + Gap Symbol + Result2 + Gap Symbol...+ Stop Symbol.

- ◆ **Start Symbol:** First enter the value for **Start Symbol Length**. As shown in the following picture, a length of 3 means that the start symbol is three characters. Refer to the ASCII table in Section 8.6 for the hexadecimal values corresponding to the ASCII characters.

Start Symbol Start Symbol Length :

Byte0	54	30	00	00	00	00	00	00	00	00	00	00	00	00	00	00
	T	0	NUL													

Gap Symbol Gap Symbol Length :

Byte0

- **Gap Symbol:** first enter the **Gap Symbol Length**. As shown in the following picture, setting the length to 1 means that the gap symbol is one character. Refer to the ASCII table in Section 8.6 for the hexadecimal values corresponding to the ASCII characters.

The screenshot shows a configuration window for the Gap Symbol. At the top left, there is a tab labeled "Gap Symbol". To its right, the text "Gap Symbol Length:" is followed by a text input field containing the number "1". Below this, the label "Byte0" is positioned above a row of six hexadecimal value boxes: "2C", "00", "00", "00", "00", and "00". A small comma is visible below the first box. A vertical blue scrollbar is on the right side of the window.

- **Stop Symbol:** first enter the **Stop Symbol Length**. As shown in the following picture, setting the length to 1 means that the stop symbol is one character. Please refer to the ASCII table in Section 8.6 for the hexadecimal values corresponding to the ASCII characters.

The screenshot shows a configuration window for the Stop Symbol. At the top left, there is a tab labeled "Stop Symbol". To its right, the text "Stop Symbol Length:" is followed by a text input field containing the number "1". Below this, the label "Byte0" is positioned above the first of sixteen hexadecimal value boxes: "0D", "00", "00", "00", "00", "00", "00", "00", "00", "00", "00", "00", "00", "00", "00", and "00". The label "Byte8" is above the eighth box, and "Byte15" is above the last box. Below the first box, the text "CR" is displayed. A vertical blue scrollbar is on the right side of the window.

After you complete these settings, the system outputs data through the Ethernet port according to these settings when you select private code output.

8.8 Ethernet Modbus Server Mode Communication Method

Modbus Master (Server) communication mode is divided into Modbus ASCII and Modbus TCP

- In the DMV2000 Main window, click **System > Communication Setting > Protocol Setting > Ethernet** and then select **Modbus**.

If you need to send the command format in ASCII, select **Modbus ASCII** for **Modbus Type**.

Protocol Setting

External Terminal
Ethernet
RS232
RS485

Port: 2048

IP Address: 192 . 168 . 1 . 3

Protocol: Private Code Modbus

Detail Setup:

Data Format: 16 Bits

ModBus Type: Modbus ASCII

Start Address: 1000 H

ID: 1

- In the DMV2000 Main windows, click **System > Communication Setting > Protocol Setting > Ethernet** and then select **Modbus**.

If you need to send the command format in TCP, select **Modbus Tcp** for **Modbus Type**.

Protocol Setting

External Terminal
Ethernet
RS232
RS485

Port: 2048

IP Address: 192 . 168 . 1 . 3

Protocol: Private Code Modbus

Detail Setup:

Data Format: 16 Bits

ModBus Type: Modbus Tcp

Start Address: 1000 H

ID: 1

- When you select Modbus, select the **RS232** and **RS485** check boxes in **Result Output > Device Choose**. Then the system starts sending data and commands to the mechanical arm or other manufacturer's PLC.

Device Choose

RS232 RS485 FTP

Ethernet SD Card SD Card 2

External Terminal

8.8.1 Ethernet Modbus ASCII Server Mode Command Table

When the inspection is completed, the DMV2000 sends the data in Modbus ASCII format.

➤ **Write 06 Single Entry Write Command Description:** (sends the correctly written data string as is)

Output format

000000000000	:	01	06	1000	0001	E8	CR	LF
	Header	Node ID	Function code (write)	Function address	Write data	Parity	Suffix	

Send format

000000000000	:	01	06	1000	0001	E8	CR	LF
	Header	Node ID	Function code (write)	Function address	Write data	Parity	Suffix	

➤ **Write 10 Multiple Entry Write Command Description:** (maximum length of 6 entries)

Output format

000000000000	:	01	10	1070	0002	04	0060	0015	F4	CR	LF
	Header	Node ID	Function code	Function address	Writes	Byte count	Data 1	Data 2	Parity	Suffix	

Send format

000000000000	:	01	10	1070	0002	6E	CR	LF
	Header	Node ID	Function code	Function address	Writes	Parity	Suffix	

Parity check:

Sum two-by-two, then take the two's complement of the last two digits (add in hexadecimal without header).

For example: 0110107000020400600015 F4 CR LF

$01+10+10+70+00+02+04+00+60+00+15 = 10C$ (take the last 2 codes 0C)

Calculate the one's complement = $FF - 0C = F3$ (one's complement is FF minus the value)

Calculate the two's complement = $F3 + 1 = F4$ (two's complement is the sum of one's complement and 1)

8.8.2 Ethernet Modbus TCP Server Mode Command Table:

When the inspection is completed, the DMV2000 sends the data in Modbus TCP format.

- ◎ **Write 06 Single Entry Write Command Description:** (sends the correctly written data string as is)

Output format

000000000000	01	06	1000	0001
	Node ID	Function code (write)	Function address	Write data

Send format

000000000000	01	06	1000	0001
	Node ID	Function code (write)	Function address	Write data

- ◎ **Write 10 Multiple Entry Write Command Description:** (maximum length of six entries)

Output format

000000000000	01	10	1070	0002	04	0060	0015
	Node ID	Function code	Function address	Writes	Byte count	Data 1	Data 2

Send format

000000000000	01	10	1070	0002
	Node ID	Function code	Function address	Writes

8.9 Ethernet Modbus TCP Communication Method

When you select the Modbus TCP/IP communication mode, the system acts in slave (Client) mode.

8.9.1 Ethernet Client Mode Command Table: (Modbus TCP Communication Format)

R indicates support for Read commands (03H code; maximum 64 entries).

W indicates support for Write commands (write single entry: 06H code; write multiple entries: 10H code; maximum six entries).

- ⊙ **Read 03 Read Command Description:** (read single or multiple data entries controlled by the **Byte** parameter)

Output format

000000000000	01	03	1010	0002
	Node ID	Function code (read)	Function address	Data ID

Return format

000000000000	01	03	04	0010	0015
	Node ID	Function code (read)	Number of entries (Byte)	Result 1	Result 2

- ⊙ **Write 06 Single Entry Write Command Description:** (returns the correctly written data string as is)

Output format

000000000000	01	06	1000	0001
	Node ID	Function code (write)	Function address	Write data

Return format

000000000000	01	06	1000	0001
	Node ID	Function code (write)	Function address	Write data

◎ **Write 10 Multiple Entry Write Command Description:** (maximum length of six entries)

Output format

000000000000	01	10	1070	0002	04	0060	0015
	Node ID	Function code	Function address	Writes	Byte count	Data 1	Data 2

Return format

000000000000	01	10	1070	0002
	Node ID	Function code	Function address	Writes

◆ **MODBUS TCP Communication Address Table**

Position	Function code supported	Name	Description	Permission	
				Run	Edit
1000H(W)	(06H)	Trigger 1 action	Trigger if Data 1 is written	○	
1001H(W)	(06H)	Trigger 2 action	Trigger if Data 1 is written	○	
1002H(W)	(06H)	Trigger 3 action	Trigger if Data 1 is written	○	
1003H(W)	(06H)	Trigger 4 action	Trigger if Data 1 is written	○	
1010H–104FH(R)	(03H)	Output data (total 64 entries)	(please refer to the following descriptions for output data)	○	
1050H(W)	(06H)	Switch to RUN mode	Trigger if Data 1 is written		○
1051H(W)	(06H)	Switch to PROG mode	Trigger if Data 1 is written	○	
1060H(R/W)	(03H,06H)	Read/switch program ID	0–999(0–31 internal memory; 32–999memory card)	○	○
1062H(R/W)	(03H,06H)	Read/switch window ID	0–127	○	
1070H(W)	(10H)	Read upper/lower (window)	Data ID to read	○	
1071H(W)			Window ID to read		
1072H(R)	(03H)		Read upper limit (Low word)		
1073H(R)	(03H)		Read upper limit (High word)		
1074H(R)	(03H)		Read lower limit (Low word)		
1075H(R)	(03H)		Read lower limit (High word)		

Chapter 8 Serial Communication

1077H(W)	(10H)	Write upper/lower (window)	Data ID to write					
1078H(W)			Window ID to write					
1079H(W)			Write upper limit (Low word)					
107AH(W)			Write upper limit (High word)					
107BH(W)			Write lower limit (Low word)					
107CH(W)			Write lower limit (High word)					
1090H(R/W)	(03H,06H,10H)	Read/set date and time	Date (year) (00–99)	○	○			
1091H(R/W)	(03H,06H,10H)		Date (month) (01–12)					
1092H(R/W)	(03H,06H,10H)		Date (day) (01–31)					
1093H(R/W)	(03H,06H,10H)		Time (hour) (00–23)					
1094H(R/W)	(03H,06H,10H)		Time (minute) (00–59)					
1095H(R/W)	(03H,06H,10H)		Time (second) (00–59)					
10A0H(W)	(10H)	Set camera shutter speed	Camera ID (1–2)	○				
10A1H(W)			Shutter speed (1–15)					
10A2H(W)	(10H)	Set camera gain and brightness	Camera ID (1–2)	○				
10A3H(W)			Gain (00–100)					
10A4H(W)			Luminance (00–100)					
10A5H(W)	(10H)	Password type	0: Old password 1: New password	○	○			
10B0H(W)	(06H)	Enable input trigger	Trigger if Data 1 is written	○				
10B1H(W)	(06H)	Disable input trigger	Trigger if Data 1 is written	○				
10B2H(W)	(06H)	Save all program setting	Trigger if Data 1 is written		○			
10B3H(W)	(06H)	Capture image	Trigger if Data 1 is written	○	○			
10B4H(W)	(06H)	Clear statistics	Trigger if Data 1 is written	○	○			
10B5H(W)	(06H)	System reset	Trigger if Data 1 is written	○				
10F0H(W)	(10H)	Read window parameter	Window ID (0–127)	○	○			
10F1H(W)			Item number (0–20)					
10F2H(R)	(03H)		Window parameter (low word)					
10F3H(R)	(03H)		Window parameter (high word)					
10F7H(W)	(10H)		Write window parameter			Window ID (0–127)	○	○
10F8H(W)						Item number (0–20)		

10F9H(W)			Window parameter (low word)		
10FAH(W)			Window parameter (high word)		

Common Error Message Code

- ⊙ **Error Handling (W):** Return string
 - 00000000000001860178: function code unsupported
 - 00000000000001860277: write address error

Error Handling (R): Return string

- 0000000000000183017B: function code unsupported
- 0000000000000183027A: read address error

1) Trigger 1 Action 1000H (W) (Run Mode enabled)

Input string: 000000000000010610000001 Return string: 000000000000010610000001

- ⊙ **Description:** after writing a "1", the switch is successful if the string returned is identical.
After triggering in Modbus mode, the system does not automatically send results after completing an inspection. The system saves the inspection result in the 1010H–104H register. When Ready turns ON again, send the Read command to get the inspection results.
- ⊙ **Error Handling:** return string
 - 00000000000001860376: incorrect content or length of write data (only one entry is allowed).
 - 00000000000001860475: unable to execute (system permits incorrect operating status and trigger source interface).

2) Trigger 2 Action 1000H (W) (Run Mode enabled)

Input string: 000000000000010610010001 Return string: 000000000000010610010001

- ⊙ **Description:** after writing a "1", the switch is successful if the string returned is identical.
After triggering in Modbus mode, the system does not automatically send results after completing an inspection. The system saves the inspection result in the 1010H–104H register. When Ready turns ON again, send the Read command to get the inspection results.
- ⊙ **Error Handling:** return string
 - 00000000000001860376: incorrect content or length of write data (only one entry is allowed),
 - 00000000000001860475: unable to execute (system permits incorrect operating status and trigger source interface),

3) Trigger 3 Action 1000H (W) (Run Mode enabled)

Input string: 00000000000010610020001 Return string: 00000000000010610020001

- ⊙ **Description:** after writing a "1", the switch is successful if the string returned is identical.
After triggering in Modbus mode, the system does not automatically send results after completing an inspection. The system saves the inspection result in the 1010H–104H register. When Ready turns ON again, send the Read command to get the inspection results.
- ⊙ **Error Handling:** return string
 - 0000000000001860376: incorrect content or length of write data (only one entry is allowed).
 - 0000000000001860475: unable to execute (system permits incorrect operating status and trigger source interface).

4) Trigger 4 Action 1000H (W) (Run Mode enabled)

Input string: 00000000000010610030001 Return string: 00000000000010610030001

- ⊙ **Description:** after writing a "1", the switch is successful if the string returned is identical.
After triggering in Modbus mode, the system does not automatically send results after completing an inspection. The system saves the inspection result in the 1010H–104H register. When Ready turns ON again, send the Read command to get the inspection results.
- ⊙ **Error Handling:** return string
 - 0000000000001860376: incorrect content or length of write data (only one entry is allowed).
 - 0000000000001860475: unable to execute (system permits incorrect operating status and trigger source interface).

5) Output Data 1010H–104FH (R) (Run Mode enabled)

Output the previous inspection result if there is no inspection program to run.

16 Bits (Word) Data Mode: if two data entries need to be returned (50,000, 300)

Input string: 00000000000010310100002 Return string: 00000000000010304C350012C

- ⊙ **Description:** 50,000 is C350 (hex) and 300 is 12C (hex).

32 Bits (Double Word) Data Mode: if two data entries need to be returned (400,000, 300)

Input string: 00000000000010310100004

Return string: 0000000000001030800061A80000012C

- ⊙ **Description:** 400,000 is 61A80 (hex) and 300 is 12C (hex).
- If output value exceeds 65535, set the data format to 32 bit to prevent writing to the wrong register.

Judge (0/1) Data Format: (return bit 2=0, bit 3=1, bit 4=1)

Input string: 00000000000010310100001 Return string: 000000000000103020018

- ⊙ **Description:** 0018 (hex) is 0000000000011000 (binary)
 - ◆ The Judge output format is 16 bit regardless of the settings (16 bit or 32 bit).
For example, suppose the return data is 400,000 and a set of Judge values of bit 2=0, bit 3=1, bit 4=1)
Read 3 entries of string lengths: 00000000000010310100003 (one entry of DW data and one entry of W Judge content)
The system returns 0000000000001030600061A800018

Error Handling: return string

- 0000000000001830478: unable to execute (system permits incorrect operating status).

6) Switch to RUN Mode 1050H (W) (Edit Mode enabled)

Input string: 00000000000010610500001 Return string: 00000000000010610500001

- ⊙ **Description:** after writing a "1", the switch is successful if the string returned is identical.
- ⊙ **Error Handling:** return string
 - 0000000000001860376: incorrect content or length of write data (only one entry is allowed).
 - 0000000000001860475: unable to execute (system permits incorrect operating status).

7) Switch to Edit Mode 1051H (W) (Run Mode enabled)

Input string: 00000000000010610510001 Return string: 00000000000010610510001

- ⊙ **Description:** after writing a "1", the switch is successful if the string returned is identical.
- ⊙ **Error Handling:** return string
 - 0000000000001860376: incorrect content or length of write data (only one entry is allowed).
 - 0000000000001860475: unable to execute (system permits incorrect operating status).

8) Read/Switch Program ID 1060H (R/W) (Run Mode and Edit Mode enabled)

Read Program ID: (returns the current program ID 10)

Input string: 00000000000010310600001 Return string: 00000000000010302000A

- ⊙ **Description:** 10 (dec) is 000A (hex).

Switch Program ID: (switch program ID to 20)

Enter string 00000000000010610600014 Return string 00000000000010610600014

- ⊙ **Description:** 20 (dec) is 0014 (hex).
After writing the value, the switch is successful if the string returned is identical.

- ⊙ **Error Handling:** return string
 - 0000000000001830379: incorrect content or length of read data (only one entry is allowed).
 - 0000000000001860376: incorrect write data length (only one entry is allowed); program ID does not exist (or no configured).

9) Read/Switch Window ID 1062H (R/W) (Run Mode enabled)

Read Window ID: (returns current window ID 50)

Input string: 00000000000010310620001 Return string: 000000000000103020032

- ⊙ **Description:** 50 (dec) is 0032 (hex).

Switch Window ID: (switch window ID to 30)

Input string: 0000000000001061062001E Return string: 0000000000001061062001E

- ⊙ **Description:** 30 (dec) is 001E (hex).

After writing the value, the switch is successful if the string returned is identical.

- ⊙ **Error Handling:** return string
 - 0000000000001830379: incorrect content or length of read data (only one entry is allowed).
 - 0000000000001830478: unable to execute (system permits incorrect operating status).
 - 0000000000001860376: incorrect content or length of write data (only one entry is allowed); window ID does not exist (or not configured).
 - 0000000000001860475: unable to execute (system permits incorrect operating status).

10) Read Upper/Lower (Window) 1070H–1075H (Run Mode enabled)

The following six registers are required to read the upper/lower limits of Window.

1070H (R/W): data item number to read/write

1071H (R/W): window ID to read/write

1072H (R): upper read limit (low word)

1073H (R): upper read limit (high word)

1074H (R): lower read limit (low word)

1075H (R): lower read limit (high word)

- ◆ 1070H data ID and 1071H window ID are first written to the registers to be accessed, then the upper and lower data limits can be read 1072H–1075H

Read Upper/Lower Limit: (i.e., data ID =2, window ID = 5, upper and lower limits are 500,000 and 300)

First enter string 000000000000110107000020400020005 Return string:

00000000000011010700002

- ⊙ **Description:** entering two words is represented by 0002.

Two words consist of four bytes. Enter 04

2 (dec) is 0002 (hex).

5 (dec) is 0005 (hex).

Then enter the read string: 00000000000010310720004

Return string: 000000000000103080007A1200000012C

- ⊙ **Description:** The system reads four words, which consist of eight bytes. Enter 08.
 - Decimal 500,000 is 0007A120 (hex).
 - Decimal 300 is 0000012C (hex).

Upper and lower limits are fixed DW (32 bit) format.
- ⊙ **Error Handling:** return string
 - 00000000000001830379: incorrect content or length of read data
 - 00000000000001830478: unable to execute (system permits incorrect operating status and no data item number or window number)
 - 00000000000001860376: incorrect content or length of write data
 - 00000000000001860475: unable to execute (system permits incorrect operating status and no window ID)

11) Write Upper/Lower (Window) 1077H–107CH (Run Mode enabled)

The following six registers are required to write the upper and lower limits of the Window. Through multi-write commands, you can simultaneously write the six values to the register in the following order to modify the upper and lower limits.

1077H (W): data item number written

1078H (W): window ID written

1079H (W): upper limit written (low word)

107AH (W): upper limit written (high word)

107BH (W): lower limit written (low word)

107CH (W): lower limit written (high word)

Write Upper/Lower: (i.e., data ID =6, window ID = 20, upper/lower limits are 600,000 and 400)

Input string: 000000000000110107700060C00060014000927C000000190

Return string: 00000000000011010770006

- ⊙ **Description:** Entering six words is represented by 0006.
 - Six words consist of 12 bytes. Enter 0C.
 - Decimal 6 is 0006 (hex).
 - Decimal 20 is 0014 (hex).
 - Decimal 600,000 is 000927C0 (hex).
 - Decimal 400 is 00000190 (hex).

The upper and lower limits are fixed DW (32bits) format.
- ⊙ **Error Handling:** return string
 - 00000000000001860475: unable to execute (system permits incorrect operating status and no window ID)

12) Read/Set Date and Time 1090H–1095H (Run Mode and Edit Mode enabled)

1090H (R/W): Date (year) (00–99; do not need to add the 20 from the yyyy format)

1091H (R/W): Date (month) (01–12)

1092H (R/W): Date (day) (01–31)

1093H (R/W): Time (hour) (00–23)

1094H (R/W): Time (minute) (00–59)

1095H (R/W): Time (second) (00–59)

Read Time/Date: (for example, the content to read is 2011/07/22 08:30:58)

Input string: 000000000000010310900006

Return string: 00000000000001030C000B000700160008001E003A

© **Description:** 11 (dec) is 000B (hex).

Decimal 07 is 0007 (hex).

Decimal 22 is 0016 (hex).

Decimal 08 is 0008 (hex).

Decimal 30 is 001E (hex).

Decimal 58 is 003A (hex).

Write Time/Date: (for example, the content to write is 2011/08/25 12:30:40)

Enter string 0000000000000110109000060C000B00080019000C001E0028

Return string: 000000000000011000900006

© **Description:** 11 (dec) is 000B (hex).

Decimal 08 is 0008 (hex).

Decimal 25 is 0019 (hex).

Decimal 12 is 000C (hex).

Decimal 30 is 001E (hex).

Decimal 40 is 0028 (hex).

Single write 06 and multi-writes to the date/time are supported.

© **Error Handling:** return string

➤ 00000000000001860376: Incorrect content or length of write data

13) Set Camera Shutter Speed 10A0H–10A1H (Run Mode enabled)

The following two registers are required to write Camera shutter speed. With multi-write, both register writes can be issued at the same time.

10A0H (W): Camera ID (1–2)

10A1H (W): Shutter Speed (1–20)

01 = 6000ms	05 = 2000ms	09 = 33.33ms	13 = 4.17ms	17 = 0.2ms
02 = 5000ms	06 = 1000ms	10 = 16.67ms	14 = 2ms	18 = 0.1ms
03 = 4000ms	07 = 500ms	11 = 10ms	15 = 1ms	19 = 0.05ms
04 = 3000ms	08 = 66.67ms	12 = 8.33ms	16 = 0.5ms	20 = 0.025ms

Write Settings: for example, set Camera2 shutter speed to 0.5 ms)

Input string: 000000000000011610A00002040002000A

Return string: 000000000000011610A00002

- ⦿ **Description:** entering two words is represented by 0002.
 - Two words consist of four bytes. Enter 04.
 - 2 (dec) is 0002 (hex).
 - Decimal 10 is 000A (hex).

- ⦿ **Error Handling:** Return string
 - 00000000000001860475: unable to execute (system permits incorrect operating status and no cameras)

14) Set Camera Gain and Luminance 10A2H–10A4H (Run Mode enabled)

The following three registers are required to write Gain and Brightness. With multi-write, the three register writes can be issued at the same time.

10A2H (W): Camera ID (1–2)

10A3H (W): Gain (00–100; larger values generate brighter images)

10A4H (W): Luminance (00–100; larger values generate brighter images)

Write Settings: (for example, set Camera2 Gain and Luminance to 50 and 70, respectively)

Input string: 000000000000011010A2000306000200320046

Return string: 000000000000011010A20003

- ⦿ **Description:** 2 (dec) is 0002 (hex).
 - Decimal 50 is 0032 (hex).
 - Decimal 70 is 0046 (hex).

- ⦿ **Error Handling:** return string
 - 00000000000001860475: unable to execute (system permits incorrect operating status and no cameras)

15) Change Password 10A5H–10ADH (Run Mode and Edit Mode enabled)

The following registers are required to change the password. Use multi-write commands, and a command must be entered according to the specific password type to confirm the old password before entering a command to change the password.

10A5H (W): password type (two codes)

10A6H–10AD (W): enter password (4–16 codes and varies according to password lengths)

Write Settings: (for example, change the password from 1234 to 5678)

Input string: 00000000000011010A5000306000041424344

00000000000011010A5000306000145464748

Return string: 00000000000011010A50003

⊙ **Description:**

According to the ASCII conversion table, the numeric value 1234 is converted to 31323334.

According to the ASCII conversion table, the numeric value 5678 is converted to 35363738.

⊙ **Error Handling:** Return string

- 0000000000001860376: incorrect content or length of write data
- 0000000000001860772: unable to execute (old password input error)

HEX	ASCII	HEX	ASCII	HEX	ASCII
20	SPACE	41	A	61	a
21	!	42	B	62	b
25	%	43	C	63	c
28	(44	D	64	d
29)	45	E	65	e
2B	+	46	F	66	f
2D	-	47	G	67	g
2E	.	48	H	68	h
30	0	49	I	69	i
31	1	4A	J	6A	j
32	2	4B	K	6B	k
33	3	4C	L	6C	l
34	4	4D	M	6D	m
35	5	4E	N	6E	n
36	6	4F	O	6F	o
37	7	50	P	70	p
38	8	51	Q	71	q
39	9	52	R	72	r
3D	=	53	S	73	s

5B	[54	T	74	t
5D]	55	U	75	u
5F	_	56	V	76	v
		57	W	77	w
		58	X	78	s
		59	Y	79	y
		5A	Z	7A	z

16) Enable Trigger Input 10B0H (W) (Run Mode enabled)

Input string: 00000000000010610B00001 Return string: 00000000000010610B00001

- ⊙ **Description:** after writing the numeric value "1", the switch is successful if the string returned is identical.
- ⊙ **Error Handling:** return string
 - 0000000000001860376: incorrect content or length of write data
 - 0000000000001860475: unable to execute (system permits incorrect operating status)

17) Disable Trigger Input 10B1H (W) (Run Mode enabled)

Input string: 00000000000010610B10001 Return string: 00000000000010610B10001

- ⊙ **Description:** after writing the numeric value "1", the switch is successful if the string returned is identical.
- ⊙ **Error Handling:** return string
 - 0000000000001860376: incorrect content or length of write data
 - 0000000000001860475: unable to execute (system permits incorrect operating status)

18) Save All Program Setting 10B2H (W) (Edit Mode enabled)

Input string: 00000000000010610B20001 Return string: 00000000000010610B20001

- ⊙ **Description:** after writing the numeric value "1", saving is successful if the string returned is identical.
- ⊙ **Error Handling:** return string
 - 0000000000001860376: incorrect content or length of write data
 - 0000000000001860475: unable to execute (system permits incorrect operating status)

19) Capture Image 10B3H (W) (Run Mode and Edit Mode enabled)

Input string: 00000000000010610B30001 Return string: 00000000000010610B30001

- ⊙ **Description:** after writing the numeric value "1", image capture is successful if the string returned is identical.

- ⊙ **Error Handling:** return string
 - 0000000000001860376: incorrect content or length of write data

20) Clear Statistics 10B4H (W) (Run Mode and Edit Mode enabled)

Input string: 00000000000010610B40001 Return string: 00000000000010610B40001

- ⊙ **Description:** after writing the numeric value "1", statistics data is successfully cleared if the string returned is identical.

- ⊙ **Error Handling:** return string
 - Refer to the common error message codes

21) System Reset 10B5H (W) (Run Mode enabled)

Input string: 00000000000010610B50001 Return string: 00000000000010610B50001

- ⊙ **Description:** after writing the numeric value "1", system reset is successful if the string returned is identical.

- ⊙ **Error Handling:** return string
 - Refer to the common error message codes.

22) Read Window Parameter 10F0H–10F1H (W) 10F2H–10F3H (R) (Run Mode enabled)

Use the following four registers to read the setting value of Parameter.

10F0H (W): item number to read

10F1H (W): window ID to read

10F2H (R): read window parameter (low word)

10F3H (R): read window parameter (high word)

- ◆ The data to be accessed, Data Item Number 10F0H and Window ID 10F1H, are written to the register, then the required data can be accessed from the addresses 10F2H–10F3H.

Read Upper/Lower: (that is, read W010, the binary lower limit of Area, which is 50)

First enter string 00000000000010610F00001 Return string: 00000000000010610F00001

- ⊙ **Description:** 1 (dec) is 0001 (hex).

First enter string 00000000000010610F1000A Return string: 00000000000010610F1000A

- ⊙ **Description:** 10 (dec) is 000A (hex).

Then enter read string: 00000000000010310F20002

Return string: 0000000000001030400320000

- ⊙ **Description:** 50 (dec) is 0032 (hex).

The content is fixed to the DW (32 bit) data structure.

- ⊙ **Error Handling:** return string

- 00000000000001830379: incorrect content or length of read data
- 00000000000001830478: unable to execute (system permits incorrect operating status and no window ID or item number)
- 00000000000001860475: unable to execute (system permits incorrect operating status and no item number)

23) Write Window Parameter 10F7H–10FAH (W) (Run Mode enabled)

Use the following four registers to write the setting value of Parameter. Through multi-write commands, four entries of numeric values can be simultaneously written to the register to change the upper and lower limits.

10F7H (W): item number to write

10F8H (W): window ID to write

10F9H (W): write window parameter (low word)

10FAH (W): write window parameter (high word)

Write Upper/Lower: (for example, write W001; the Edge Intensity parameter of Edge Position is 20)

Numeric values must be written to 10F7H in order. Select the item number to write, write the window ID to the address 10F8H, and then write the numeric values to configure.

Input string: 000000000000011010F70004080002000100140000

Return string: 000000000000011010F70004

- ⊙ **Description:** 20 (dec) is 0014 (hex).

Upper/lower limits are fixed DW (32 bit) format.

- ⊙ **Error Handling:** return string

00000000000001860475: unable to execute (system permits incorrect operating status and no item number)

Chapter 9

Appendix

9.1 Locate

The Locate tool makes ROI inspections possible when the orientation of the target object changes as shown in the following diagram. Before using the Locate tool, inspections can only be performed at fixed positions. When the position of the target object deviates, a fixed ROI cannot be used due to the deviation in the position of the target object.

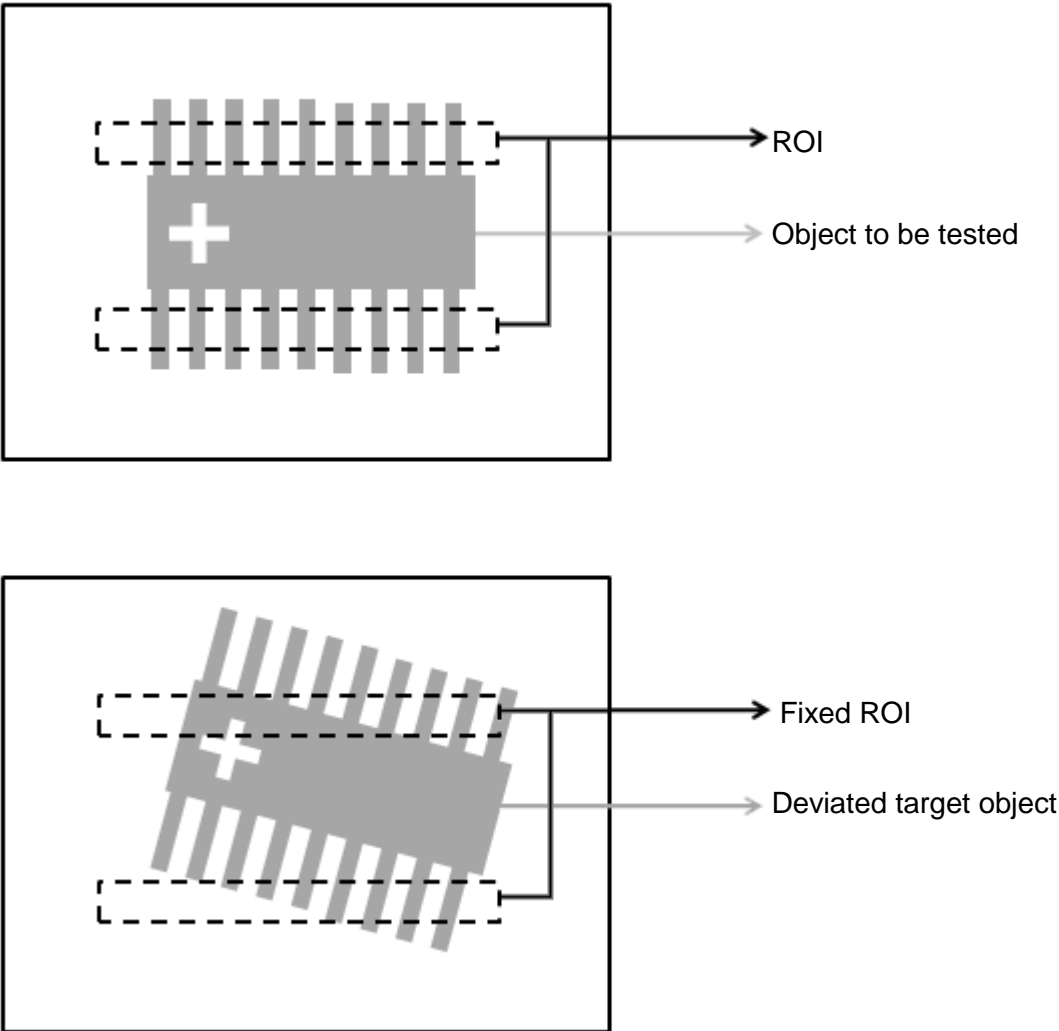

The Locate tool can identify a feature on the target object to confirm the object position before correcting the position of the ROI. As shown in the following diagram, Locate can use the crosshair on the target object to confirm the object position. Locate can then correct the position the ROI.

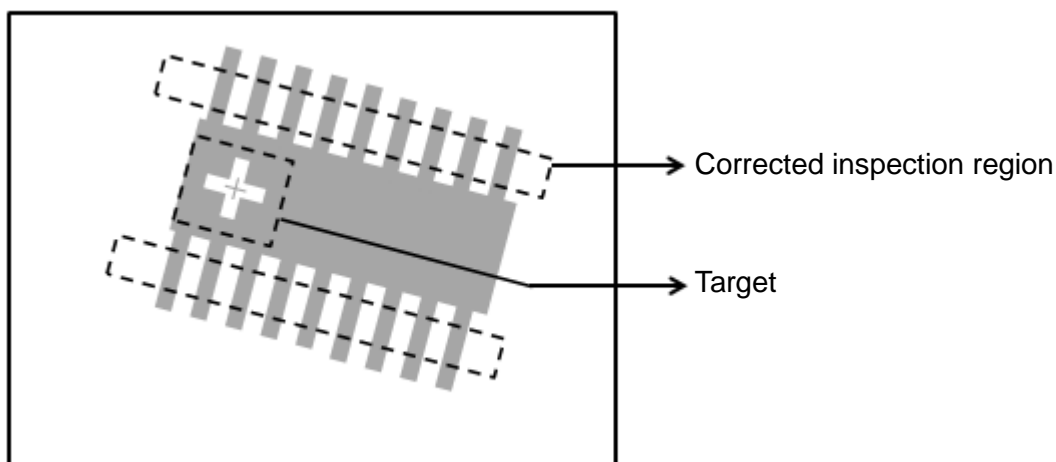

9.1.1 Locate Parameters

You can select the Ref. X, Ref. Y, and Ref. Angle in the Locate options for all inspection tools.

- **Ref. X:** Configure the ROI's reference X coordinate of the inspection tool
- **Ref Y:** Configure the ROI's reference Y coordinate of the inspection tool
- **Ref. Angle:** Configure the ROI's reference angle coordinate of the inspection tool

9.1.2 Reference Tools that Use Locate

You can use the output results of the following types of inspection tools for reference locations.

◎ **Blob**

- Ref. X:

Blob Centroid Position X [N]

Blob Bounding Rectangle Upper Left Position X [N]

- Ref Y:

Blob Centroid Position Y [N]

Blob Bounding Rectangle Upper Left Position Y [N]

- Ref. Angle:

Blob Major Axis Angle [N]

◎ **Stain**

➤ Ref. X:

Stain Centroid Position X [N]

➤ Ref Y:

Stain Centroid Position Y [N]

◎ **Angle**

➤ Ref. Angle:

Edge Angle

◎ **Pitch**

➤ Ref. X:

Edge Pitch Center Position X

Edge Pitch First Edge Position X [N]

Edge Pitch Second Edge Position X [N]

➤ Ref Y:

Edge Pitch Center Position Y

Edge Pitch First Edge Position Y [N]

Edge Pitch Second Edge Position Y [N]

➤ Ref. Angle:

Pitch Center Absolute Angle [N]

Edge Pitch First Edge Absolute Angle [N]

Edge Pitch First Edge Relative Angle [N]

Edge Pitch Second Edge Absolute Angle [N]

Edge Pitch Second Edge Relative Angle [N]

◎ **Position**

➤ Ref. X:

Edge Position X [N]

➤ Ref Y:

Edge Position Y [N]

➤ Ref. Angle:

Edge Position Edge Absolute Angle [N]

Edge Position Edge Relative Angle [N]

◎ **Shape**

▶ Ref. X:

Shape Position X [N]

▶ Ref Y:

Shape Position Y [N]

▶ Ref. Angle:

Shape Angle [N]

◎ **Position Trace**

▶ Ref. X:

Position Trace Edge Position X [N]

Position Trace Vertex Position X [N]

▶ Ref Y:

Position Trace Edge Position Y [N]

Position Trace Vertex Position Y [N]

◎ **Width Trace**

▶ Ref. X:

Width Trace Edge Width Position X1 [N]

Width Trace Edge Width Position X2 [N]

▶ Ref Y:

Width Trace Edge Width Position Y1 [N]

Width Trace Edge Width Position Y2 [N]

9.1.3 Locate Configuration Process

The following examples explain the configuration of Locate flow processes.

A register image is shown in the following picture. The Blob tool is used to inspect the number of pins on the communication terminal and the Shape tool is used for positioning.



◎ **Flow Configuration**

- 1) Create one Shape tool function for positioning and one Blob function to count the number of pins.

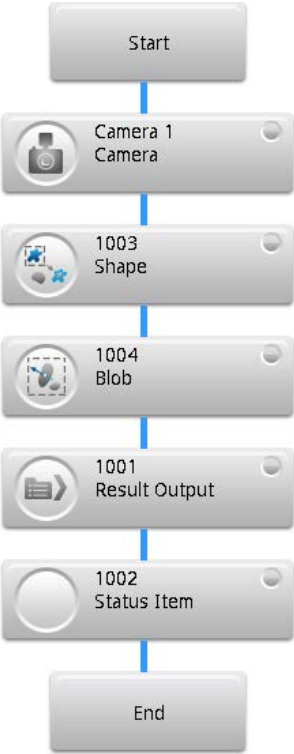

- 2) Use the same register image for both the Shape and Blob functions.
- 3) Use the shape feature of the communication terminal as the target pattern in the Shape function.

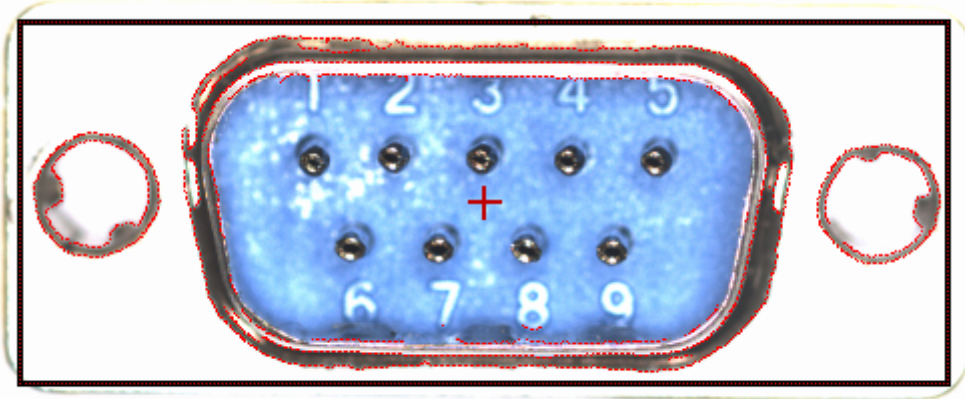

- 4) Configure the ROI as a Rectangle for the Blob function.



5) Locate is configured as shown in the following **Blob** tool dialog box. Configure **Ref. X**, **Ref. Y**, and **Ref. Angle** to **Shape Position X**, **Shape Position Y**, and **Shape Angle**, respectively.

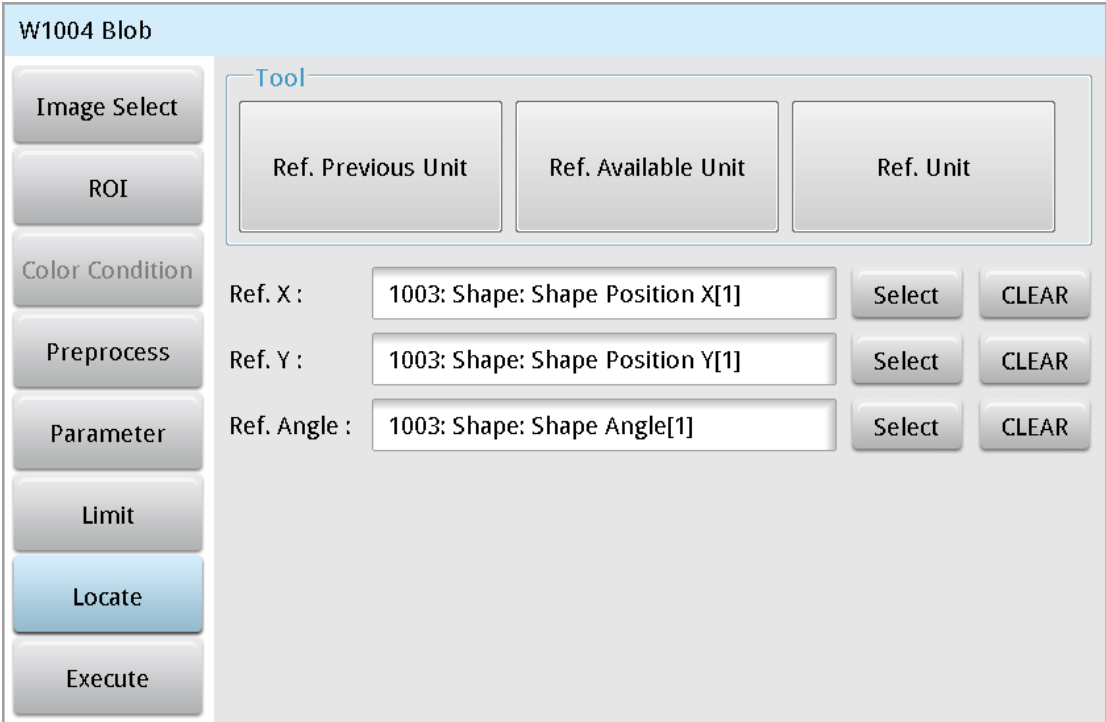

6) When the target object does not have an offset, the number of pins can be correctly counted as shown in the following operation screen.

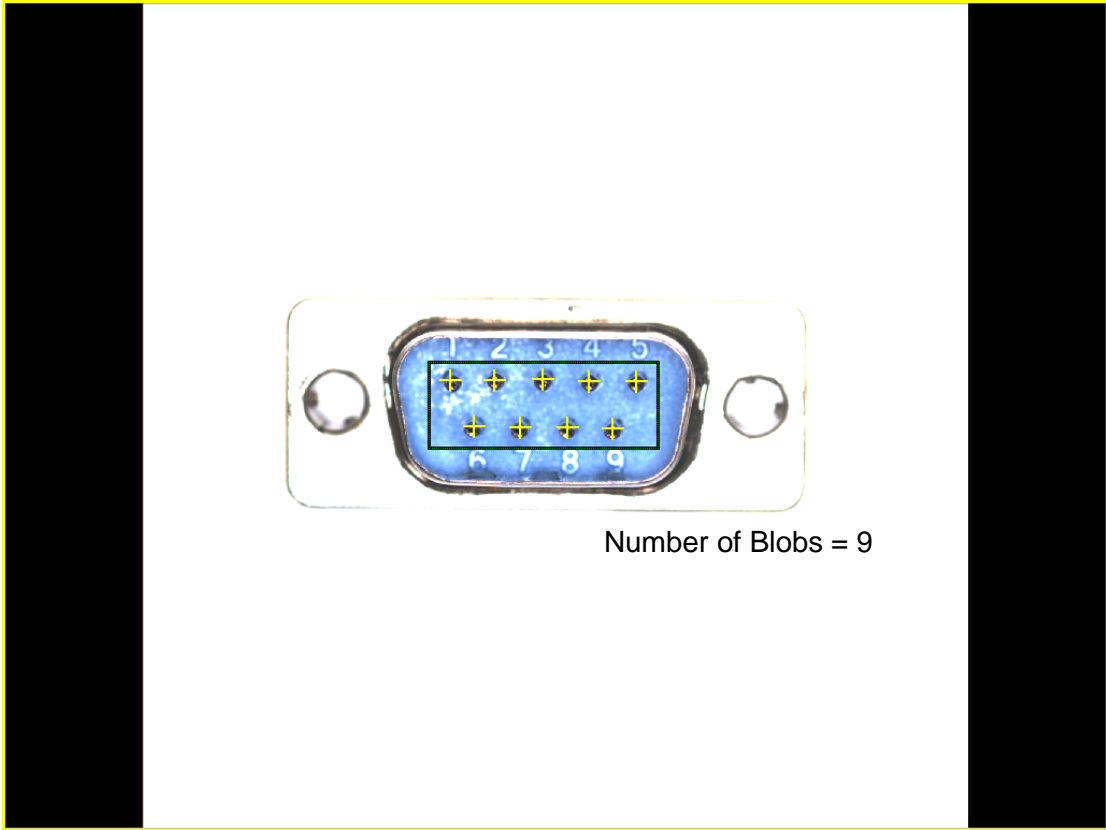

When the position of the target object deviates, the Blob function follows the Shape function, using Locate to correctly count the number of pins as long as the Shape function can correctly identify the shape.

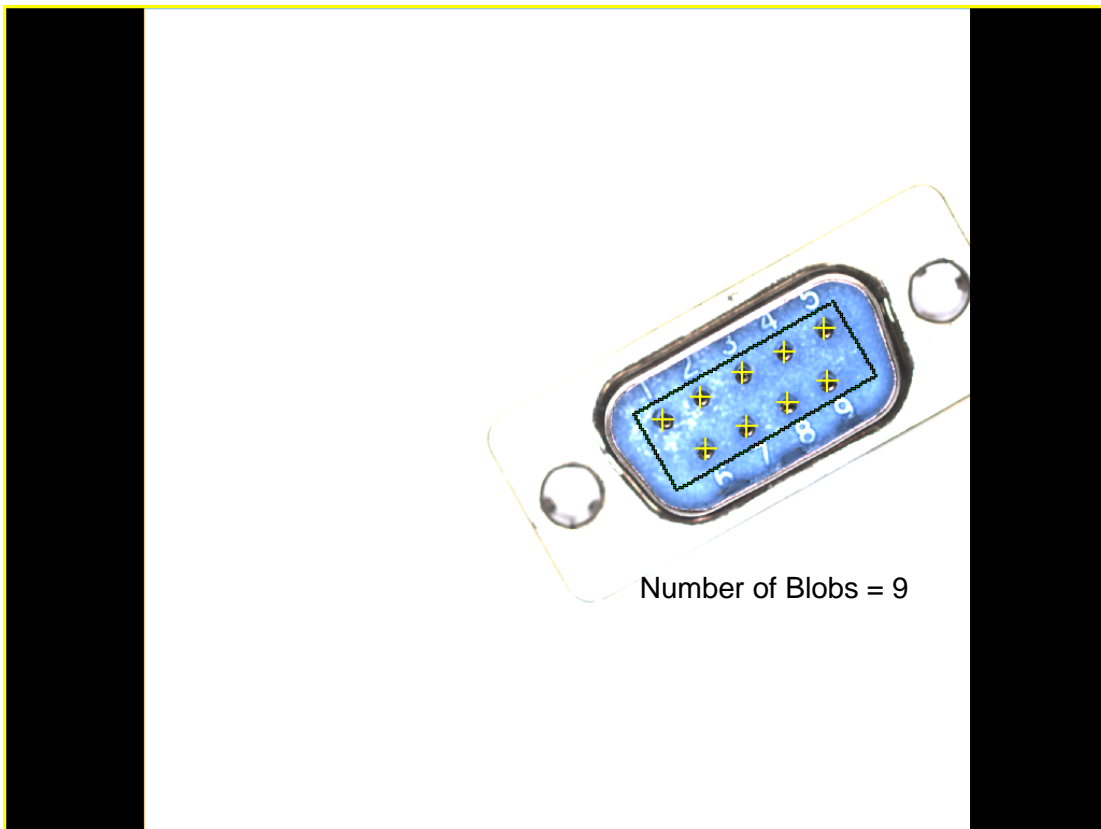
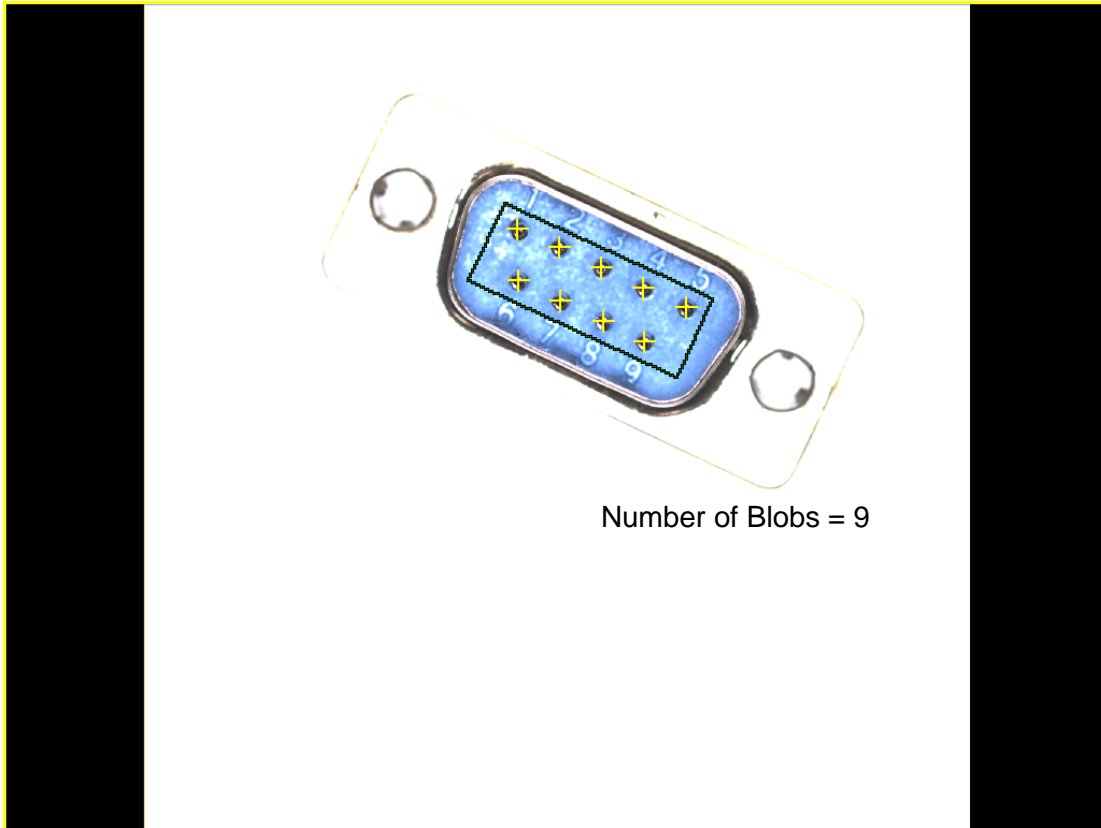

9.2 Preprocess

In the visual inspection application environment, inspections can misjudge or fail due to unclear target features in the images captured by the camera. Preprocessing the image before image processing may be required enhance features to increase the accuracy and success rate of inspections.

9.2.1 Preprocess Types

You can apply and overlay up to six sets of preprocesses to each inspection unit. You can create various effects through overlaying different preprocesses to enhance image features. The system currently supports 13 preprocess effects, including Binary, Dilate, Erosion, Average, Median, Laplacian, SobelX, SobelY, SobelXY, Intensity Adj., Contrast, Shade, and Custom.

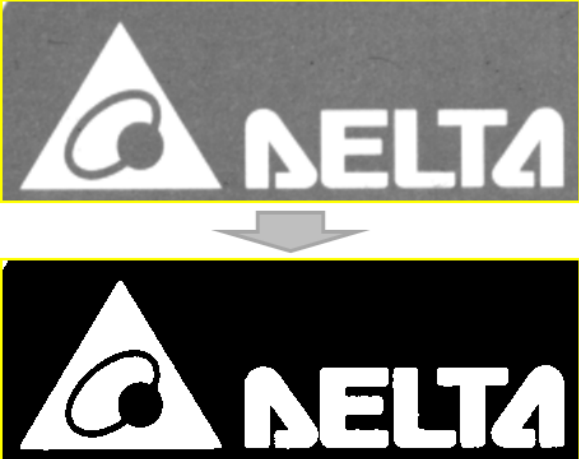
No.	Preprocess	Description	Configuration Parameter
1	No preprocess	Select None in preprocess options; the preview shows the original image captured by the camera. 	Without any preprocess function
2	Binarization	The system converts gray-scale image regions into black or white pixels. 	ON/OFF: ON Color Condition: White Histogram: Upper 255/Lower 149

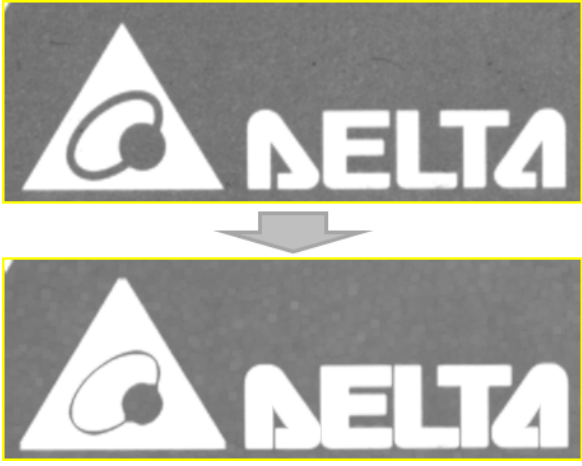
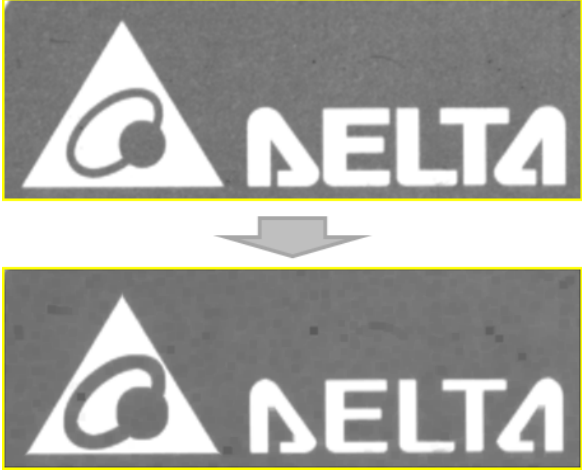
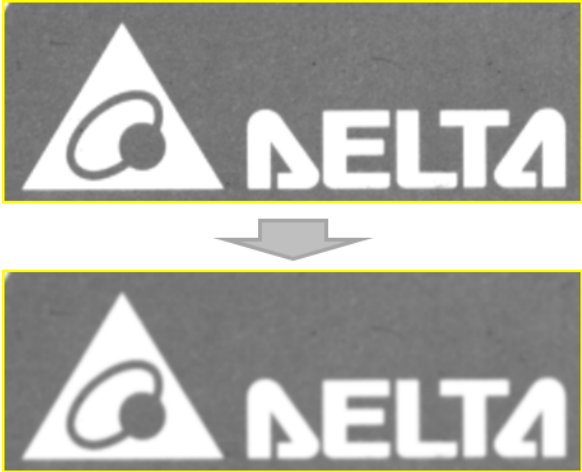
<p>3</p>	<p>Dilation</p>	<p>The system dilates (expands) the white pixels.</p> 	<p>ON/OFF: ON Filter Size: 3x3 Filter Direction: XY Frequency: 2</p>
<p>4</p>	<p>Erosion</p>	<p>The system reduces (shrinks) the white pixels.</p> 	<p>ON/OFF: ON Filter Size: 3x3 Filter Direction: XY Frequency: 2</p>
<p>5</p>	<p>Average</p>	<p>The system averages the surrounding pixels to blur the image and reduce noise.</p> 	<p>ON/OFF: ON Filter Size: 3x3 Filter Direction: XY Frequency: 2</p>

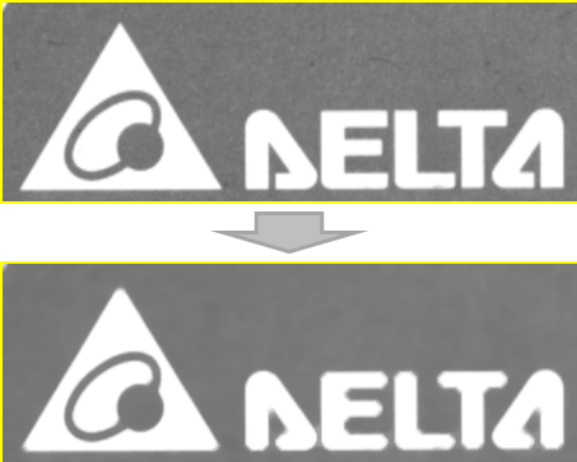
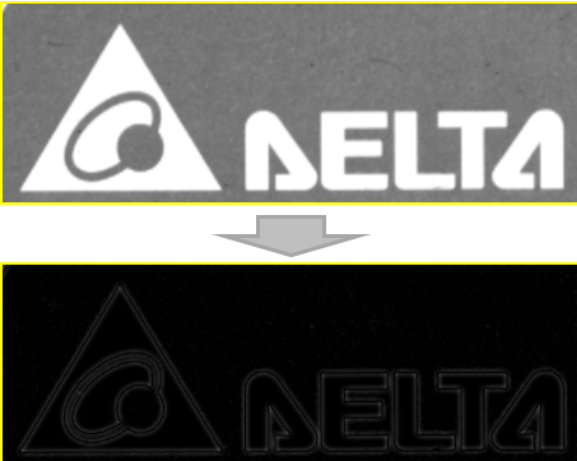
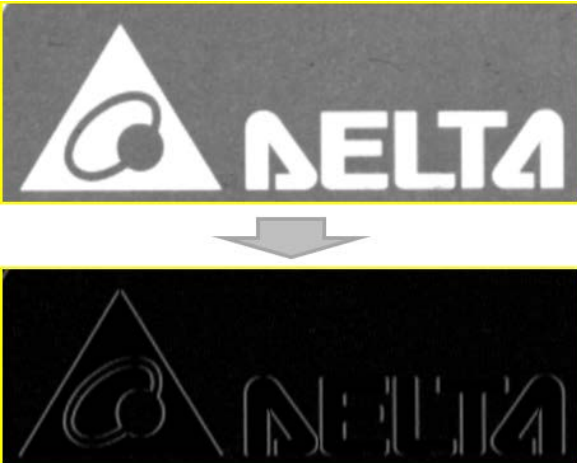
<p>6</p>	<p>Median</p>	<p>The system takes the median after comparing surrounding pixels to reduce noise without blurring the image.</p>  <p>The diagram shows two identical input images of a triangle with a circle inside and the word 'DELTA' to its right. A downward arrow points from the top image to the bottom image, indicating the application of the median filter.</p>	<p>ON/OFF: ON Filter Size: 5x5 Filter Direction: XY Frequency: 5</p>
<p>7</p>	<p>Laplacian</p>	<p>The system performs edge extraction in the XY direction with similar effects as Sobel, but the lines are thinner with stronger results at high contrasting edges</p>  <p>The diagram shows the same input image as above. A downward arrow points to the output image, which displays the edges of the triangle and 'DELTA' as thin white lines on a black background.</p>	<p>ON/OFF: ON Filter Size: 9x9 Frequency: 1</p>
<p>8</p>	<p>SobelX</p>	<p>The system extracts edges in the X direction.</p>  <p>The diagram shows the same input image as above. A downward arrow points to the output image, which displays the edges of the triangle and 'DELTA' as thin white lines on a black background, specifically highlighting the X-directional edges.</p>	<p>ON/OFF: ON Filter Size: 3x3 Frequency: 1</p>

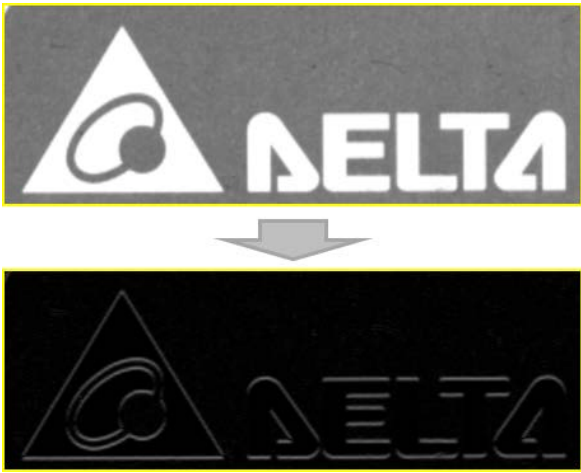
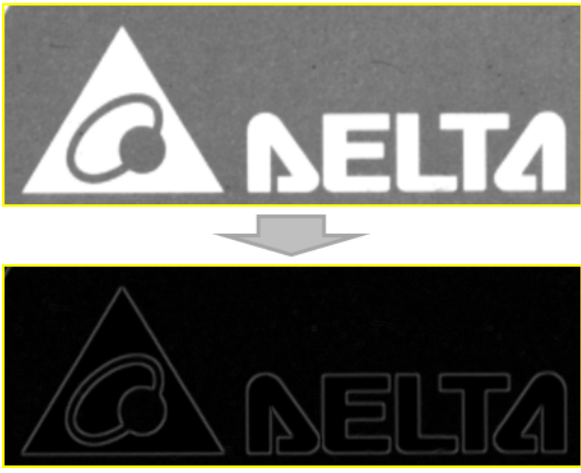
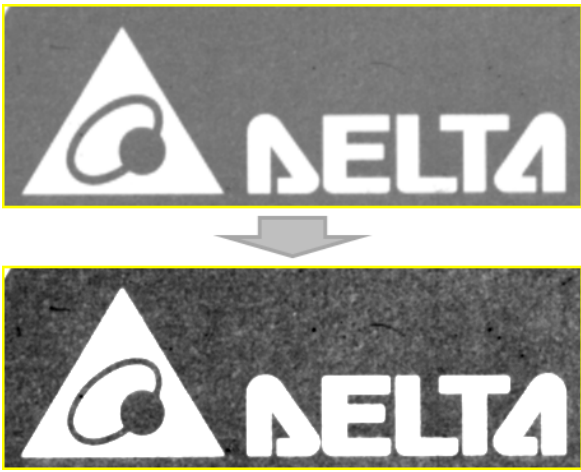
<p>9</p>	<p>SobelY</p>	<p>The system extracts edges in the Y direction.</p>  <p>The image shows the original grayscale logo 'DELTA' with a white triangle and a circle. Below it, a downward arrow points to the result of SobelY edge detection, which shows only the vertical edges of the logo in white on a black background.</p>	<p>ON/OFF: ON Filter Size: 3x3 Frequency: 1</p>
<p>10</p>	<p>SobelXY</p>	<p>The system simultaneously extracts edges in the X and Y directions.</p>  <p>The image shows the original grayscale logo 'DELTA' with a white triangle and a circle. Below it, a downward arrow points to the result of SobelXY edge detection, which shows all edges of the logo (both horizontal and vertical) in white on a black background.</p>	<p>ON/OFF: ON Filter Size: 3x3 Frequency: 1</p>
<p>11</p>	<p>Intensity Adj.</p>	<p>The system adjusts the overall brightness of the grayscale in the original image based on variations in slope and offset.</p>  <p>The image shows the original grayscale logo 'DELTA' with a white triangle and a circle. Below it, a downward arrow points to the result of Intensity Adj., which shows the same logo but with a darker, more uniform background, indicating that the overall brightness has been adjusted.</p>	<p>ON/OFF: ON Offset: -423 Slope: 4.2</p>

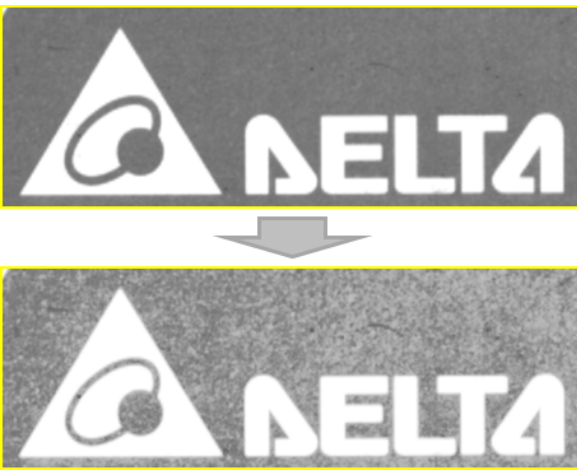
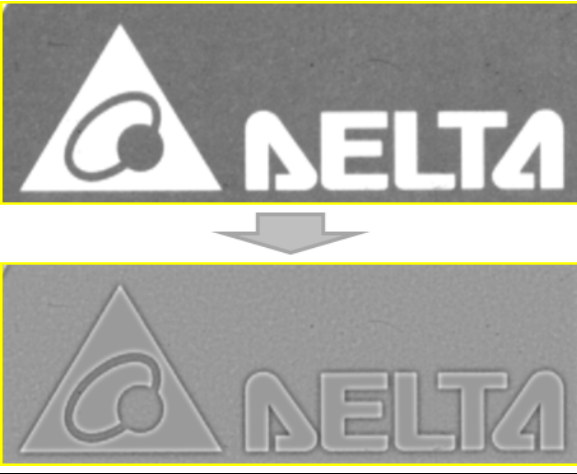
12	Contrast	<p>The system increases the contrast in the image.</p> 	ON/OFF: ON
13	Shade	<p>The system makes adjustments to emphasize the Stain effect when the gray scale on the surface of the target object is uneven.</p> 	ON/OFF: ON Filter Size: 5

9.2.2 Custom Filter

When none of the default system filters sufficiently emphasize the image features, you can create custom filters. The numerical parameters for the filter size are 3x3 and 5x5.

☉ 5x5 45-Degree Edge Strengthen

Use custom parameters to strengthen 45-degree edge features.

➤ Applied effect

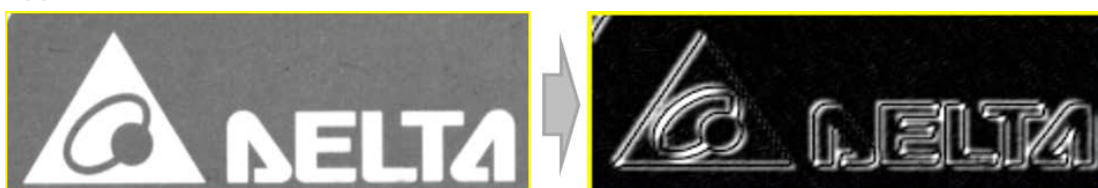

➤ Configuration Parameter

You must add and select **Custom** in the preprocess items. Set **Filter Size** to 5x5, and set **Frequency** and **Divisor** to 1, and set **Coefficient** as shown in the following picture.

Custom

ON/OFF: ON OFF

Filter Size: 3x3 5x5

Count :

Divisor:

Coefficient:

-1	0	0	0	0
0	-2	0	0	0
0	0	6	0	0
0	0	0	-2	0
0	0	0	0	-1

◎ **5x5 63-Degree Edge Strengthen**

Use custom parameters to strengthen 63-degree edge features.

➤ Applied effect

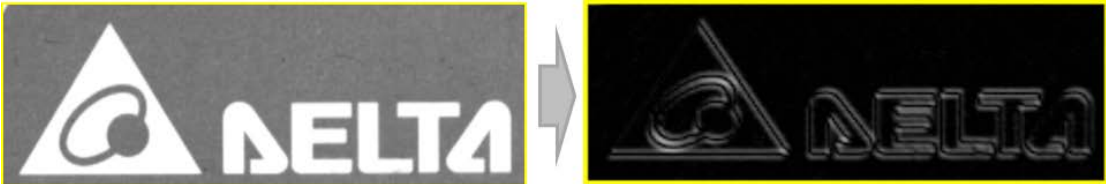

➤ Configuration Parameter

You must add and select **Custom** in the preprocess items. Set **Filter Size** to 5x5, set **Frequency** and **Divisor** to 1, and set **Coefficient** as shown in the following picture.

Custom

ON/OFF: ON OFF

Filter Size: 3x3 5x5

Count :

Divisor:

Coefficient:

0	0	0	0	0
0	0	0	0	0
0	0	2	0	0
0	0	0	0	0
0	0	0	0	0

© 3x3 Edge Strengthen

Use custom parameters to strengthen edge sharpness in the image.

► Applied effect

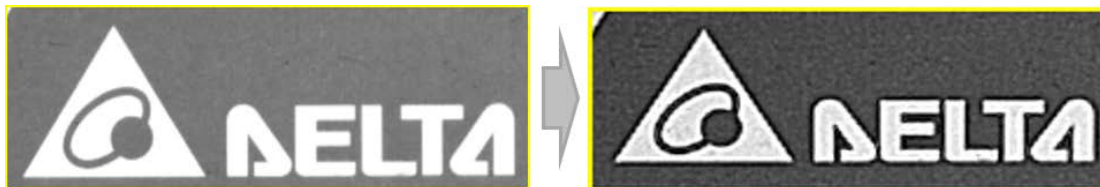

► Configuration Parameter

You must add and select **Custom** in the preprocess items. Set **Filter Size** to 3x3, set **Frequency** and **Divisor** to 1, and set **Coefficient** as shown in the following picture.

Custom

ON/OFF: ON OFF

Filter Size: 3x3 5x5

Count : 1

Divisor:

Coefficient:

-1	-1	-1
-1	9	-1
-1	-1	-1

© 3x3 45-Degree Average

Use custom parameters to highlight the average effect in the 45-degree direction.

► Applied effect

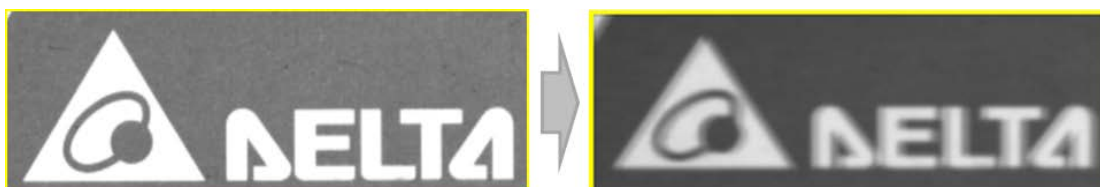

➤ Configuration Parameter

You must add and select **Custom** in the preprocess items. Set **Filter Size** to 3x3, set **Frequency** to 1, set **Divisor** to 3, and set **Coefficient** as shown in the following picture.

Custom

ON/OFF: ON OFF

Filter Size: 3x3 5x5

Count :

Divisor:

Coefficient:

1	0	0
0	1	0
0	0	1

⊙ Item Description

- **ON/OFF:** select ON to turn on preprocessing.
- **Filter Size:** Selects the filter size. The options depend on the type of filter. Average, Laplacian, SobelX, SobelY, and SobelXY use 3x3 and 5x5; 7x7 and 9x9. Filter Size in Shade is different and can be set between 1–20.
- **Filter Direction:** selects the scanning directions: X, Y, and XY.
- **Frequency:** selects the number of preprocesses.
- **Color Condition:** selects whether to search for black or white pixels.
- **Histogram:** sets the upper and lower limits for Binary.
- **Offset:** sets overall image brightness (intensity).
- **Slope:** sets image brightness and contrast. See the following pictures.

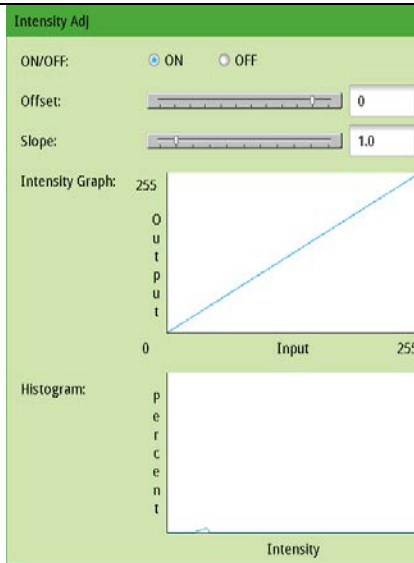
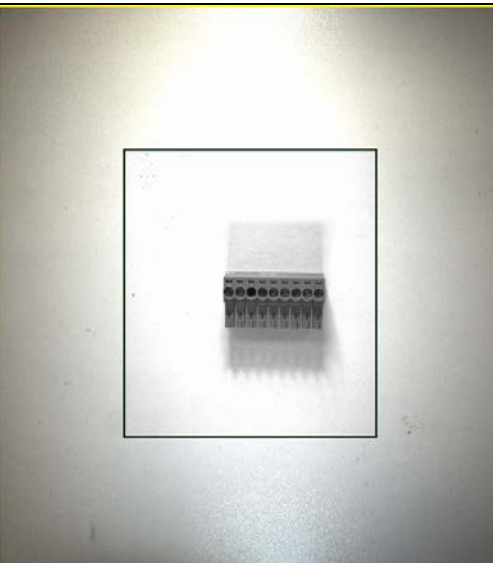
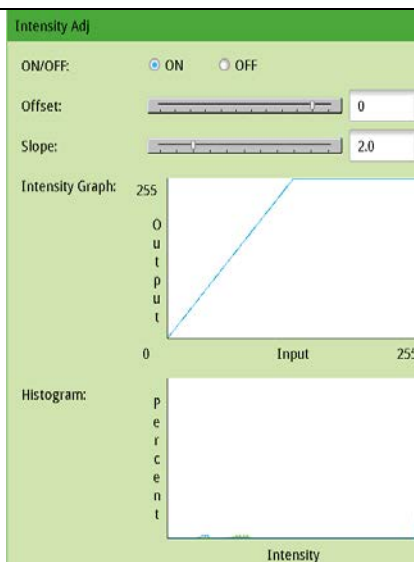
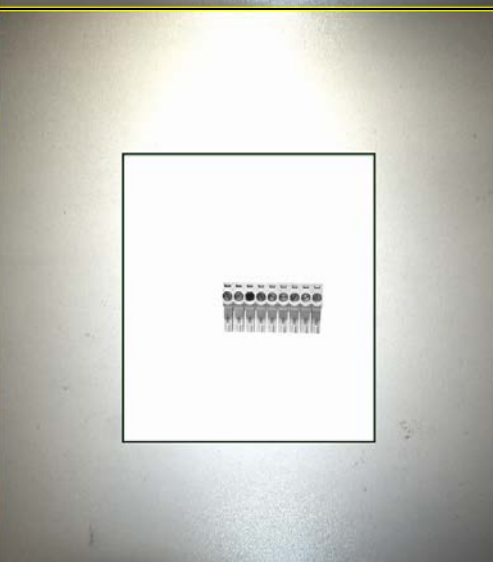
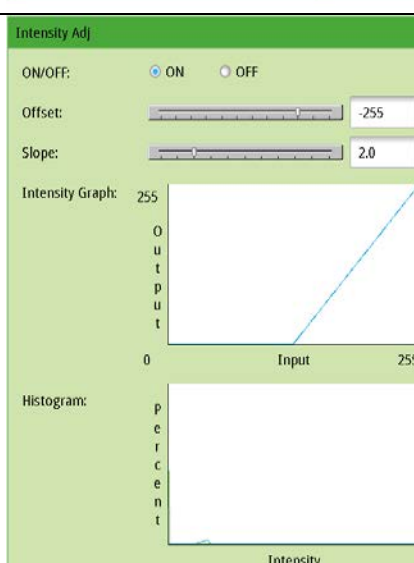
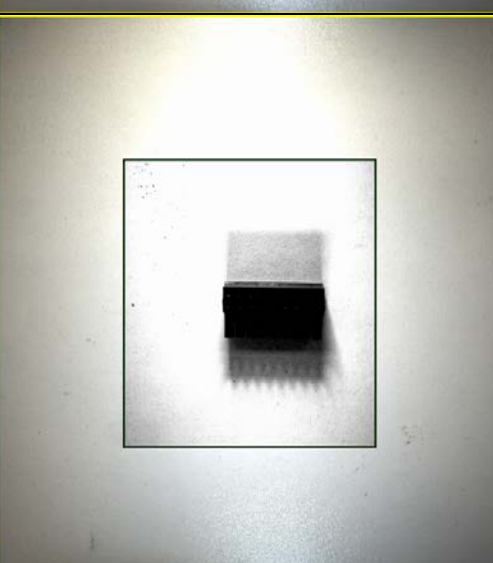
Parameter Effect Display		Description
		<p>These configuration parameters give the original image.</p> <p>Offset = 0 Slope = 1.0</p>
		<p>Adjust Slope; pixels of grayscale greater than 128 become brighter.</p> <p>Offset = 0 Slope = 2.0</p>
		<p>Simultaneously adjust Offset and Slope; pixels of grayscale less than 128 are converted to black.</p> <p>Offset = -255 Slope = 2.0</p>

◎ Strengthen Feature and Stain

When a single preprocess function cannot highlight the feature or stain, you can overlay multiple preprocess to strengthen the image and increase the system inspection accuracy. This section provides several examples.

► Highlight Stain

Using the terminal block in the following diagram as an example, you can overlay four preprocess effects to highlight the locations on the terminal block that lack fixing screws.

1) Intensity Adj.

The overall brightness of the image is non-uniform; therefore you can use Intensity Adj. first to improve image uniformity.

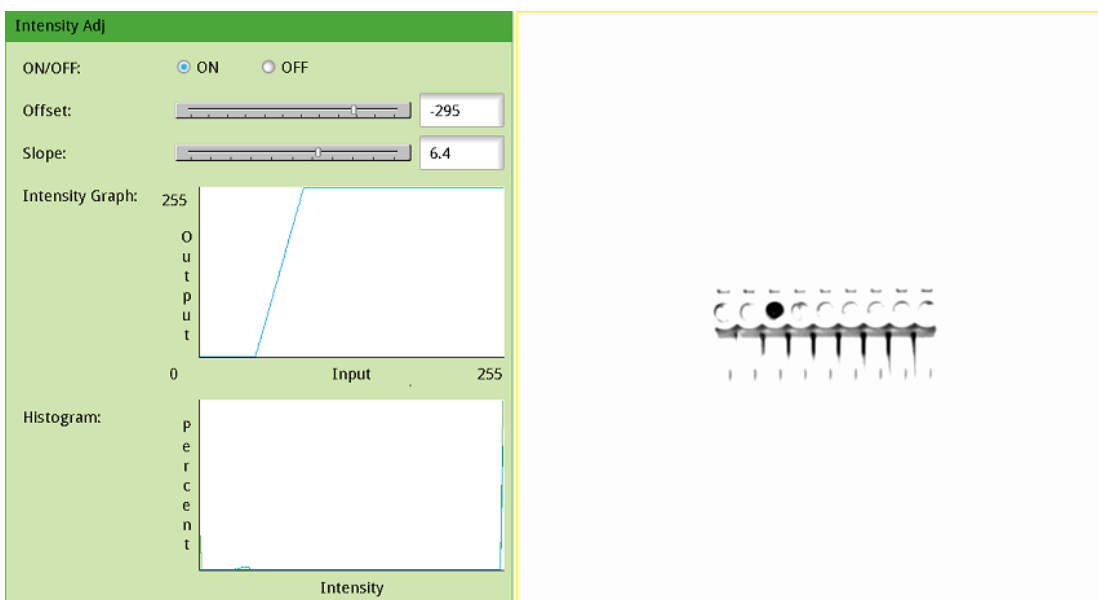

- 2) After the brightness adjustment, parts of the image have been filtered. However, some finer areas may be misjudged; therefore you can add Dilation to remove these areas.

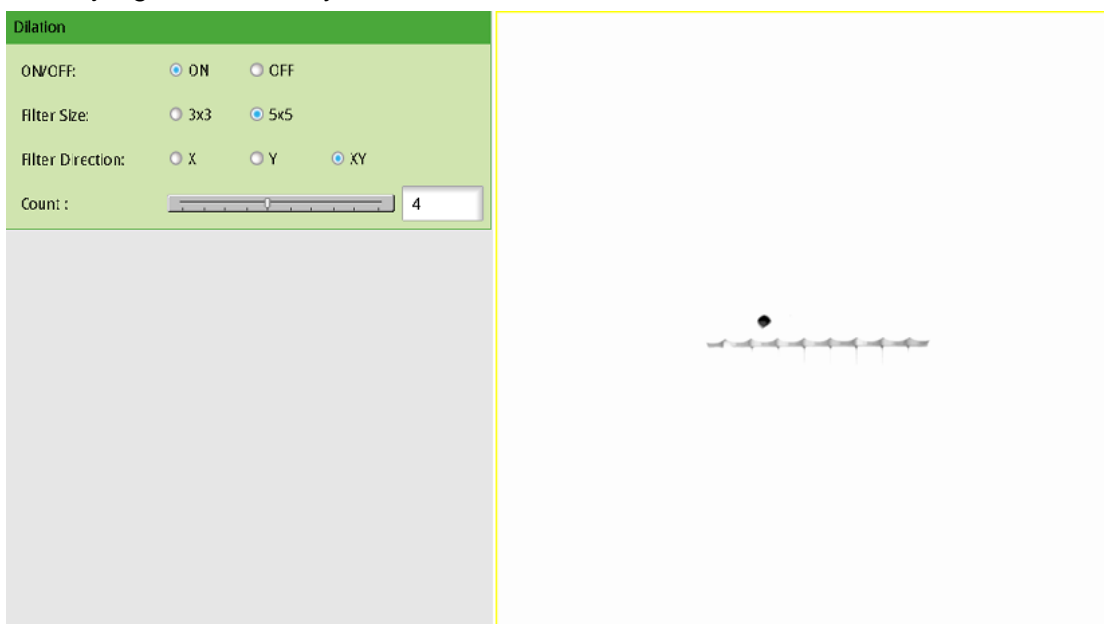

- 3) After dilating the white pixels, the areas that can cause potential misjudgment are mostly removed. However, some areas are not thoroughly cleaned in the lower edge. Adding Binary removes these areas.

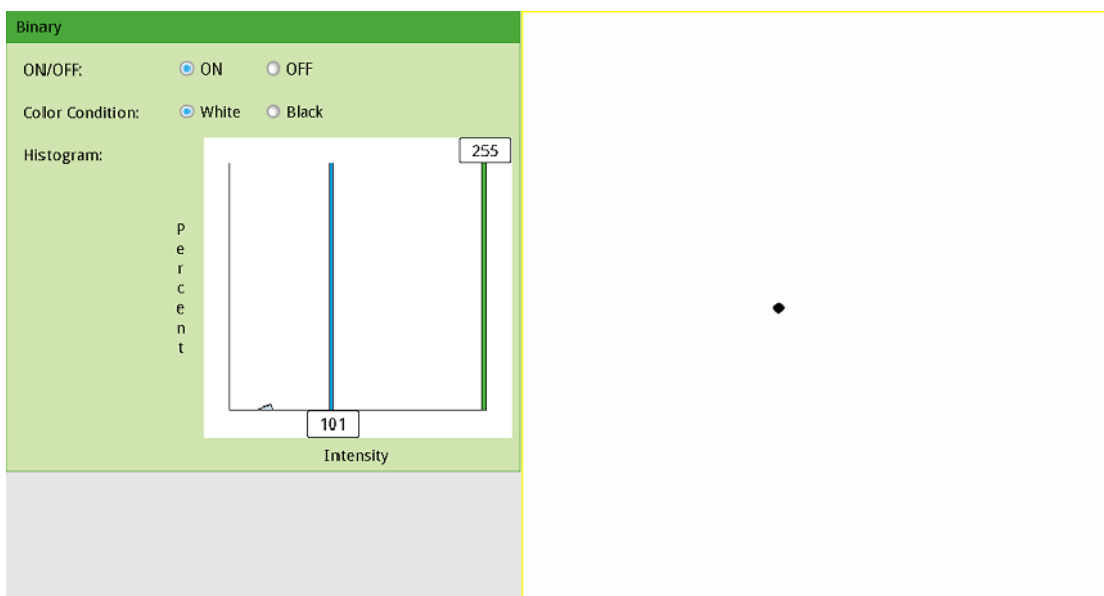

4) Through the Binary process, the stain becomes excessively small. Therefore, add Erosion to enlarge the feature to facilitate the inspection.

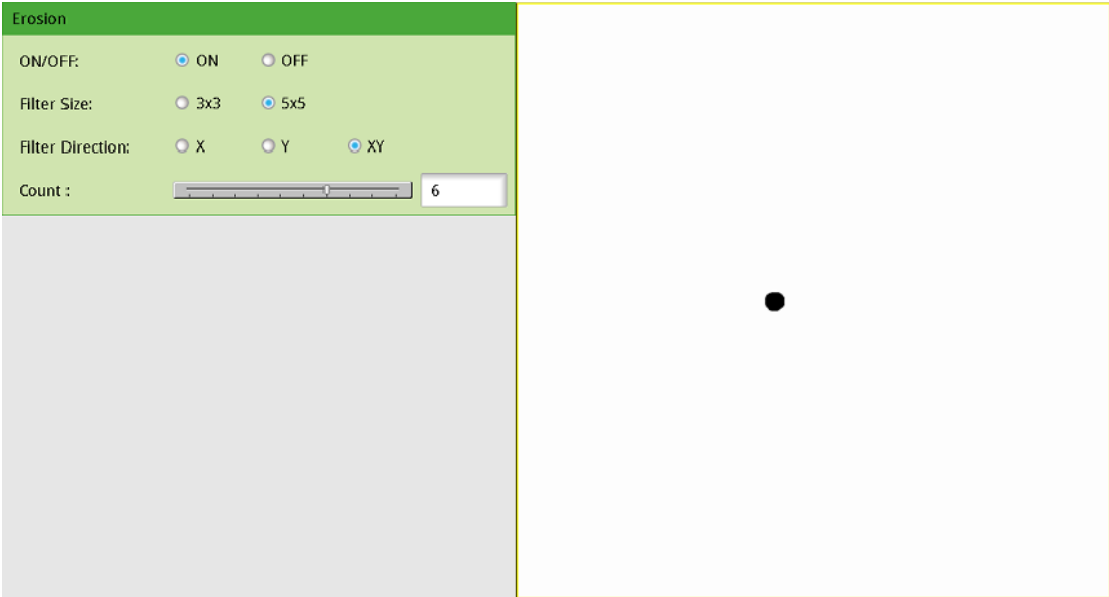

9.3 Lighting

9.3.1 Lighting Method

Lighting covers the light source as well as the relative position with the camera. The most common light sources and imaging results are described below.

⦿ **Dark Field Lighting:** Smooth surfaces appear darker.

The camera and the lens are coaxial and the angle is not perpendicular. Light hitting the smooth surface on the object reflects at a right angle away from the image sensor and light bouncing off non-smooth areas scatter into the CCD. As a result, the smooth surfaces appear darker and the rough areas appear brighter.

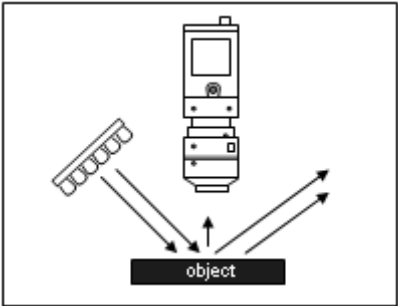

◎ **Bright Field Lighting:** Smooth surfaces appear brighter.

The camera and lens are coaxial and the angle is perpendicular. Light is directly reflected off the smooth surface on the object into the image sensor. As a result, the smooth surfaces appear brighter and the rough areas scatter light away from the CCD and thus appear darker. Therefore, bright field and dark field lighting are inversely related in image brightness/darkness. However, you should prevent glare due to bright reflections in bright field lighting.

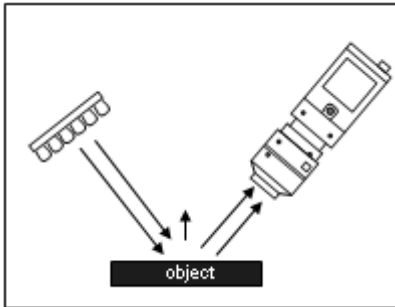

Raised text on black plastic



Target object



Dark field

◎ **Front Lighting**

Front lighting is a common technique, with ring or strip light source, and is suitable for acquiring surface images of general objects. If you install the circle light at a different angle, it casts a different shadow effect. For highly reflective objects, you can use the diffuser or diffuse softening series to clarify images.

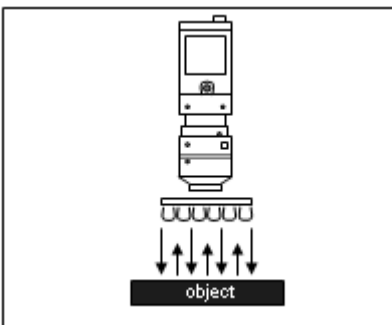

Lighting on flat



◎ **Oblique Lighting**

Oblique lighting creates side shadows when projected from the side of raised objects. The resulting image has a 2.5D effect. Among the different angles of 0°, 30°, 60°, and 90° used for general ring lighting, you can use 0° and 30° for oblique lighting.

To reduce errors in edge position caused by the shadowing, avoid using oblique lighting in edge detection.

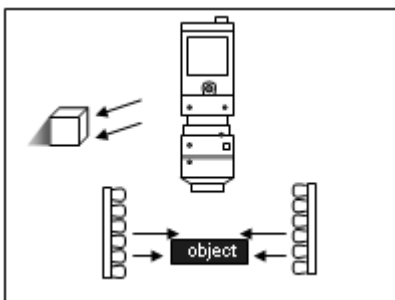

Printed text on a fuse



Target object

General Circle lighting



Low angle Circle lighting



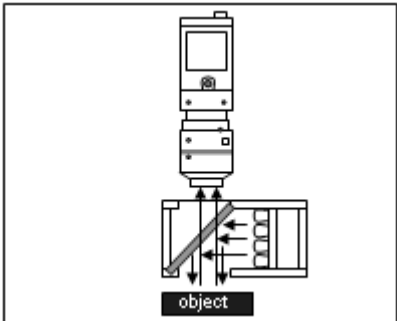

◎ **Coaxial Lighting**

The light source can be either inside or outside the lens (inner/outer coaxial). You can also use a beam splitter to create a soft light field that can reduce reflections or glare, suitable for objects with high reflectivity, such as glass or metallic material.

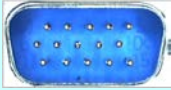
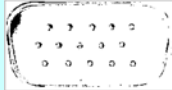

Measuring a pin connector

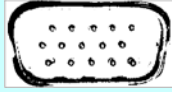
 Target object	General		
	Coaxial		

◎ **Back Lighting**

The camera can capture the object outline by shielding the light source, but the surface characteristics are lost. This is generally used for measuring an object's size, positioning, or for defect detection.

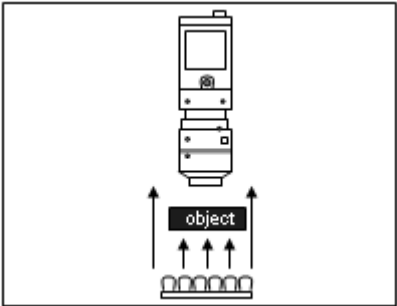

Measuring bore holes and diameters

 Target object	General ring lighting	
	Backlight	

9.4 Color

When using a color camera, every inspection tool can use the Color Condition function to extract and convert the specific colors of a color image into a binary or gray-scale image.

9.4.1 Color Condition Configuration

The following picture shows the **Color Extraction Method Setting** dialog box for color conditioning. It includes the Extraction Method Setting, Color Extraction Tool, and Color Range Setting.

Color Extraction Method Setting

Extraction Method:

Color Space: RGB HSI

Color Extraction Tool

Sensitivity:

Region:

Palette

R:
G:
B:
H:
S:
I:
Color:

Color Range Setting

Hue: Lower: Upper:

Saturation: Lower: Upper:

Intensity: Lower: Upper:

⊙ **Extraction Method**

➤ **Color to Binary**

The Color Extraction Tool extracts specific colors and converts color images to binary images. You select the color to be extracted. After processing, the extracted color is white and the remaining colors are black, as shown in the following picture.

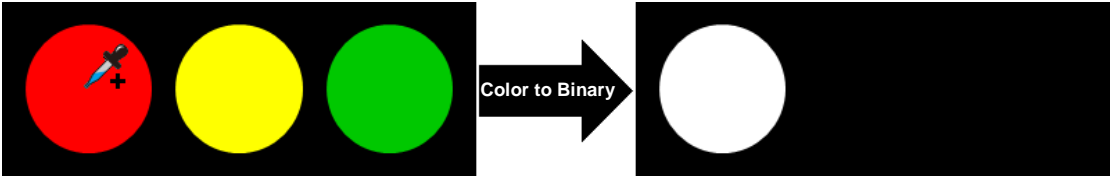

➤ **Color to Grayscale**

The Color Extraction Tool extracts specific colors and converts color images to gray-scale images. You select the color to be extracted. After processing, the extracted color is the brightest (a grayscale of value 255), as shown in the following picture.

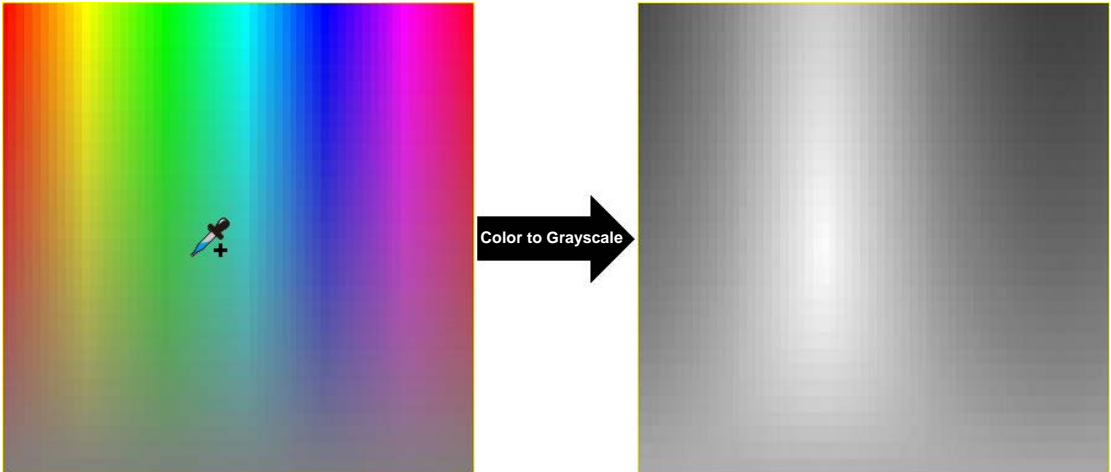

B/I

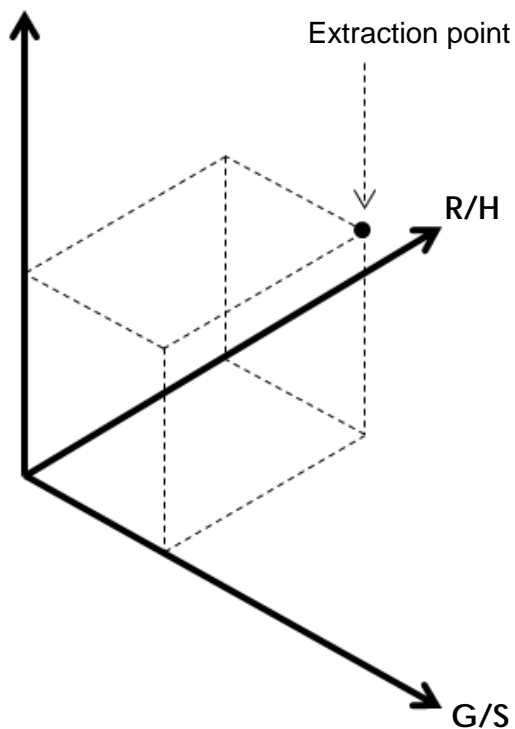

➤ **RGB Grayscale**

This selection averages the R, G, and B grayscales for each pixel, and converts the color image to a gray-scale image.

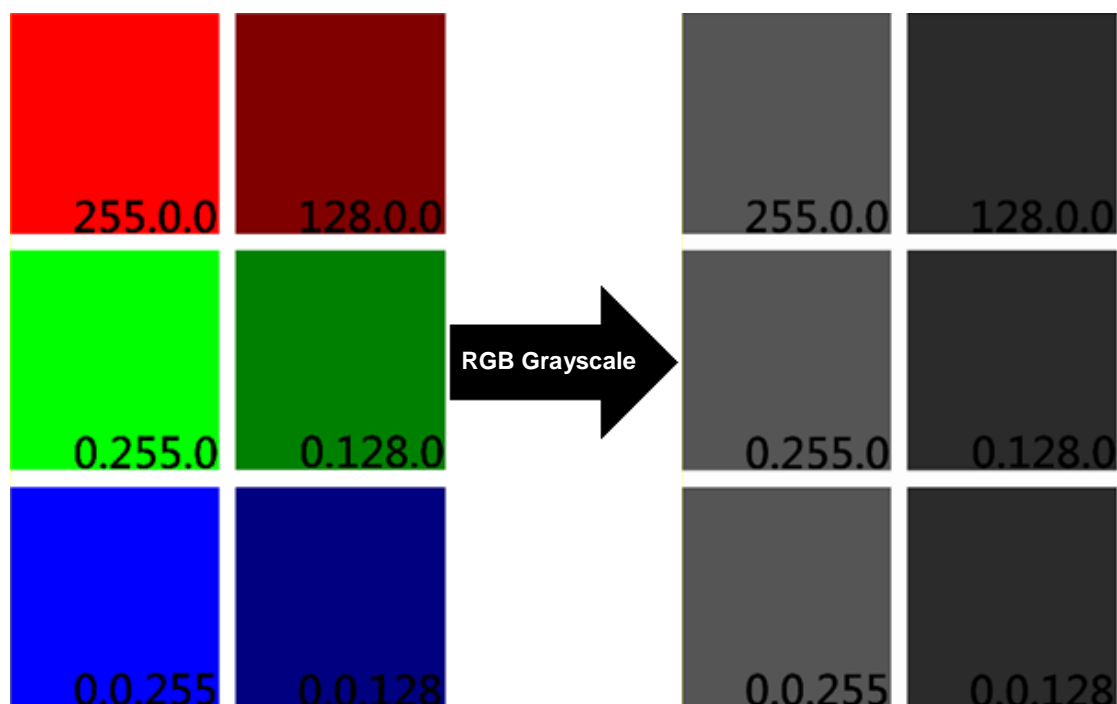

➤ **R Grayscale**

This selection extracts the R grayscale value for each pixel, and converts the color image to a gray-scale image according to the intensity of the R grayscale.

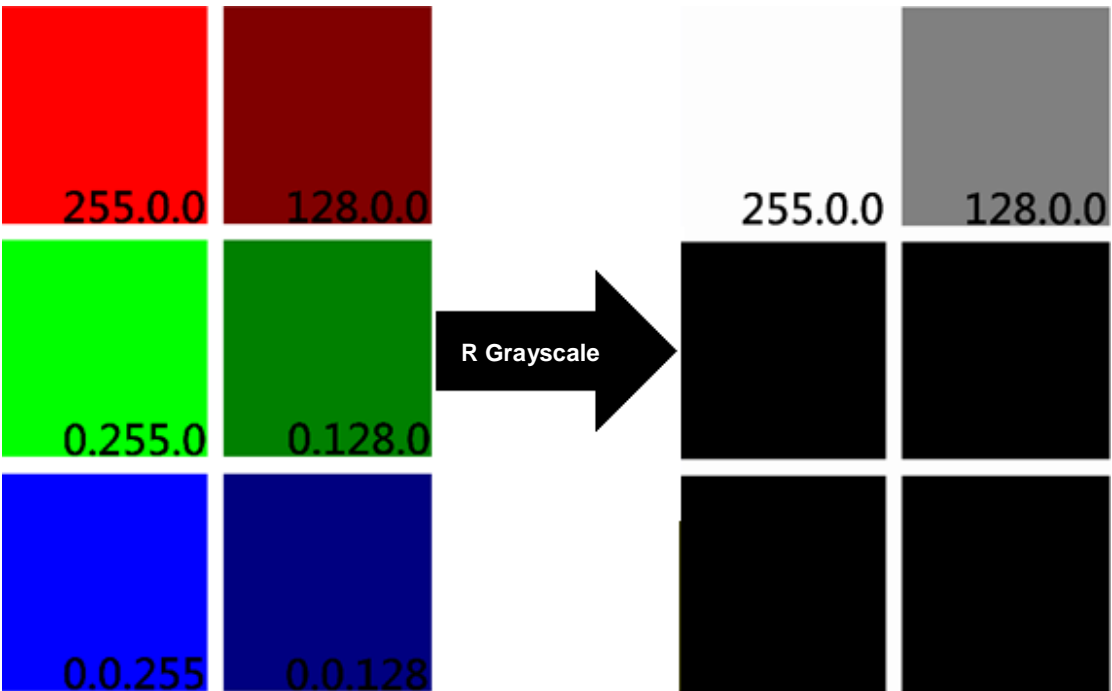

➤ **G Grayscale**

This selection extracts the G grayscale value for each pixel, and converts the color image is to a gray-scale image according to the intensity of the G grayscale.

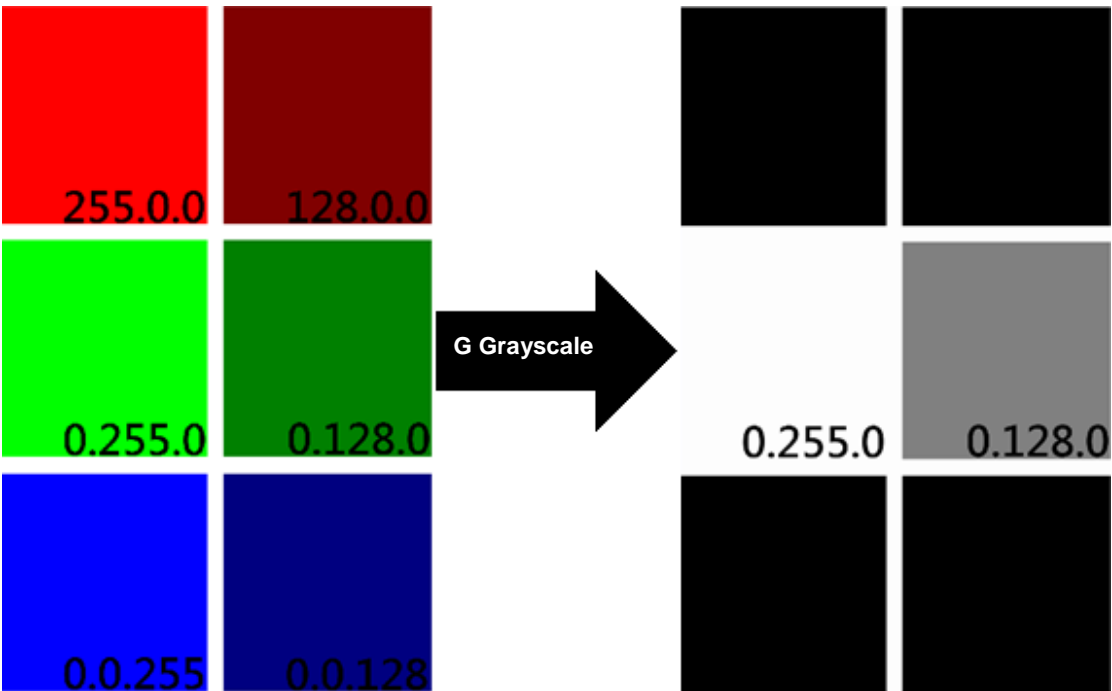

► B Grayscale

This selection extracts the B grayscale value for each pixel, and converts the color image to a gray-scale image according to the intensity of the B grayscale.

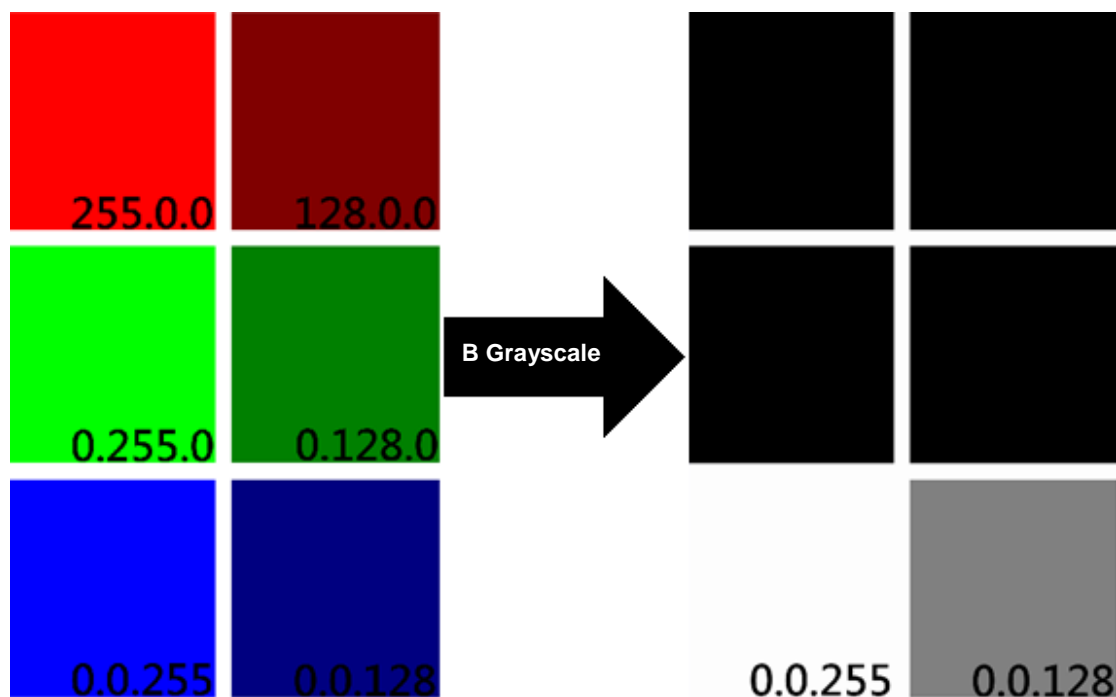

© RGB VS HSI

A color can be presented using the intensities of the three primary color R, G, and B components. For example, dark red can be $R = 50, G = 0, B = 0$ and bright red is $R = 255, G = 0, B = 0$. Dark yellow is $R = 50, G = 50, B = 0$ and bright yellow is $R = 255, G = 255, B = 0$. Therefore, you must adjust at least 2 color parameters to change color intensity and saturation when colors are defined using RGB. In addition, the adjustments are non-intuitive.

HSI is often used because it is more intuitive when using color extraction tools. Similar to RGB, HSI also uses 3 color components to represent 1 color. However, HSI uses the three components of hue (H), saturation (S), and intensity (I) instead of the red, green, and blue components of RGB (as shown in the following picture). Therefore, in HSI, the H component determines the color, the S component determines the saturation of the color, and the I component determines the intensity of the color.

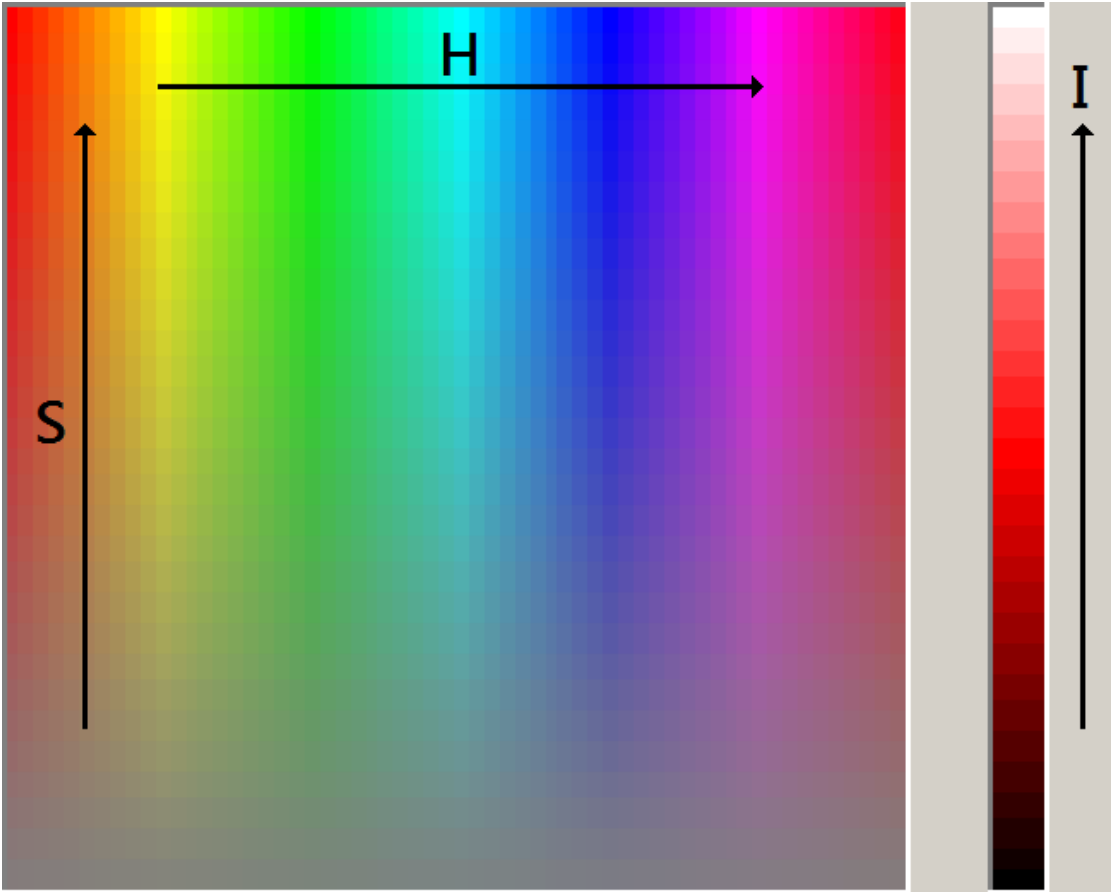

© **Color Extraction Tool**

Use the dropper tool to extract the target color from an image in the Color Extraction Tool.

- The Color Extraction Tool for the Color to Binary function appears in the following picture. Color to Binary requires extracting a color range. Therefore, when extracting colors, you use **Dropper+** and **Dropper-** repeatedly to increase or decrease the color range; Click **DropperR** to reset the extracted color range.

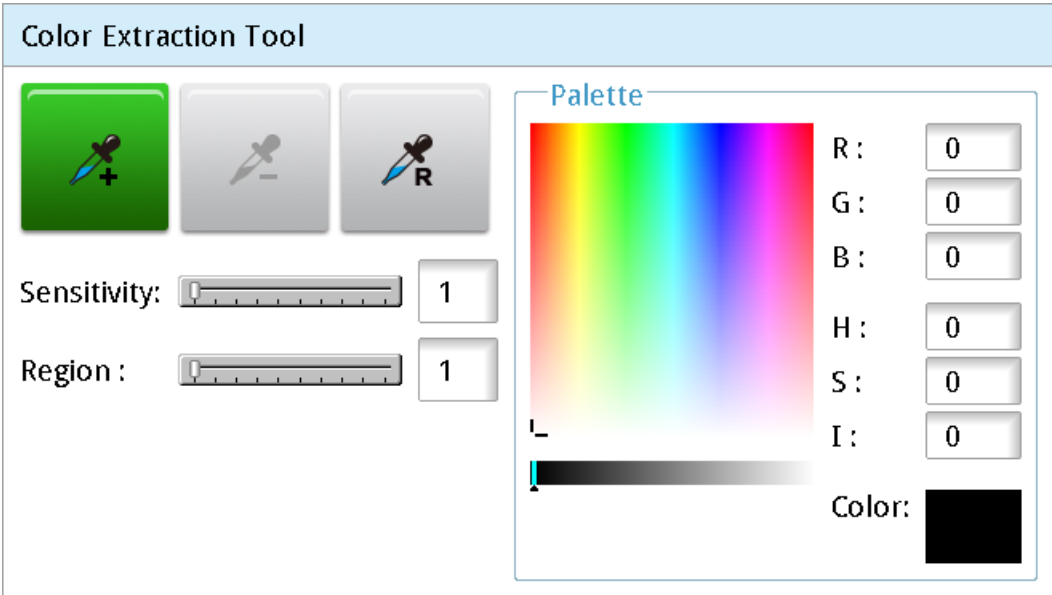

- ◆ The **Sensitivity** and **Region** settings influence the color range for each extraction. For example: the extraction position is shown in the following picture. Set **Region** and **Sensitivity** to 1 and 5, respectively.

Set **Region** to 1; the selected pixel region is extended by +/-1 pixel in the X and Y directions. The selected region becomes 3x3 which is then averaged using the RGB components. As a result, the extracted values are $R = 200 \cdot 7/9$, $G = 200 \cdot 1/9$, and $B = 200 \cdot 1/9$; $R = 156$, $G = 22$, and $B = 22$. When you set **Sensitivity** is set to 5, the extracted RGB range is extended by +/-5. The final extraction result is $R = 151-161$, $G = 17-27$, and $B = 17-27$.

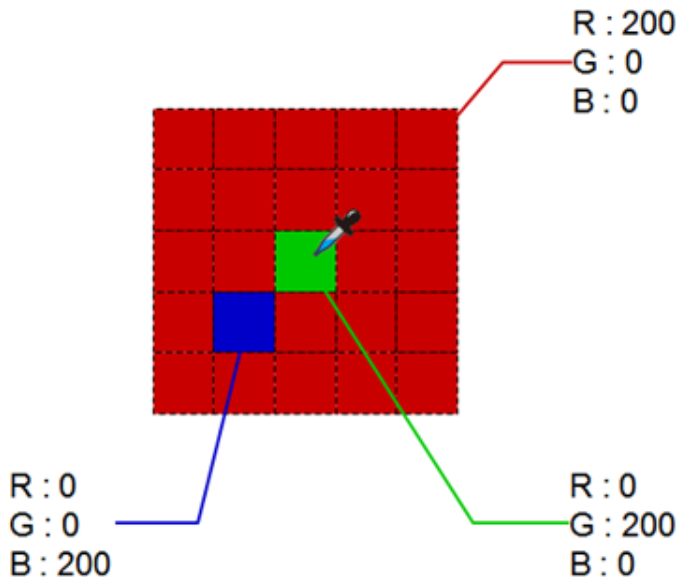

- The Color Extraction Tool for the Color to Grayscale function appears in the following picture. Color to Grayscale only extracts one specific color. Therefore, when extracting colors, you use only the **Dropper+** to extract of a single color. Use **DropperR** to reset the range of the extracted color.

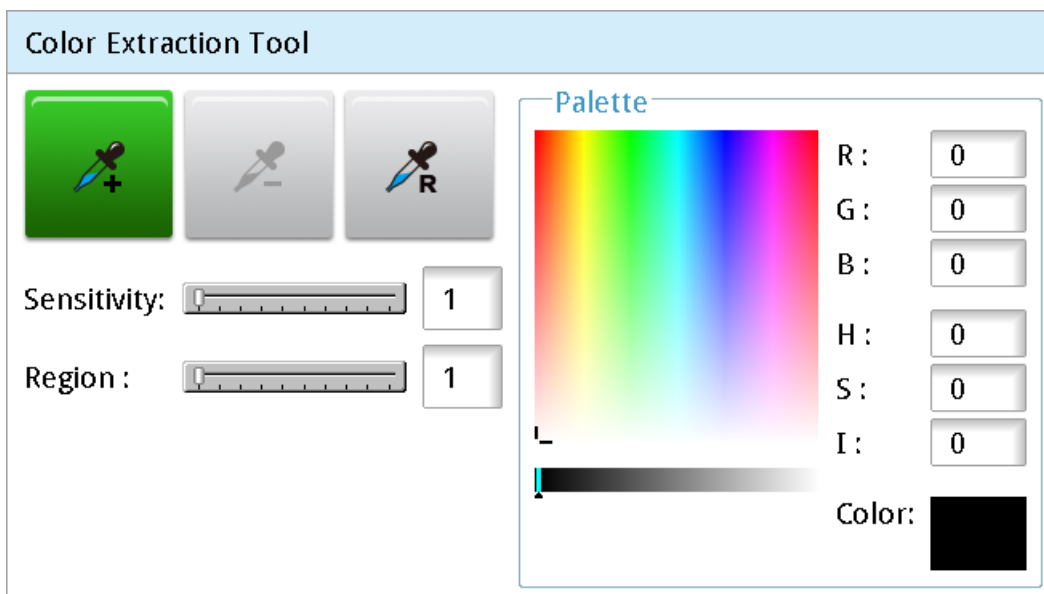

- ◆ The **Region** setting influences the extracted color, as shown in the following example. The extraction position is shown in the following picture. Set **Region** to 1; the selected pixel region is extended by +/-1 pixel in the X and Y directions. The selected region becomes 3*3 which is then averaged using the RGB components. As a result, the extracted values are $R = 200 \cdot 7/9$, $G = 200 \cdot 1/9$, and $B = 200 \cdot 1/9$, thus $R = 156$, $G = 22$, and $B = 22$.

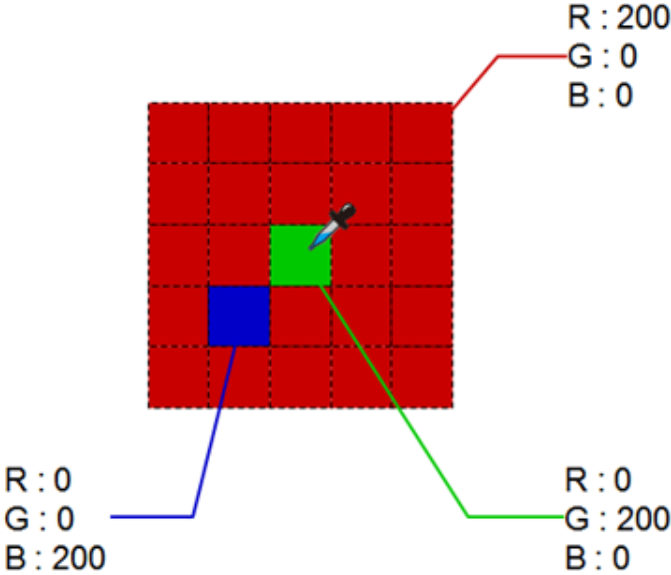

© Color Range Setting

Adjusts the extracted color range.

- The Color Range Settings for Color to Binary appears in the following picture. Drag the bars on the color picker to adjust the extracted color range. You can also enter the **Lower** and **Upper** numeric values to adjust the extracted color range.

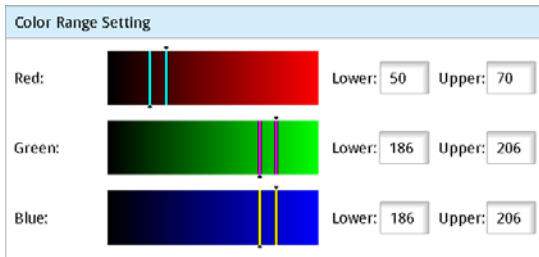

RGB color picker interface

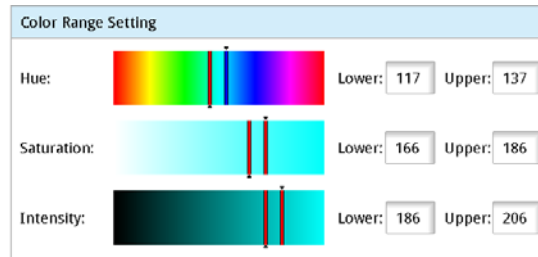

HSI color picker interface

- The Color Range Setting for Color to Grayscale appears in the following picture. Drag the bars on the color picker to adjust the color range. You can also enter the **Lower** and **Upper** numeric values to adjust the extracted color range.

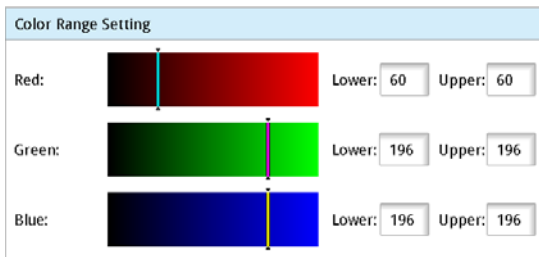

RGB color picker interface

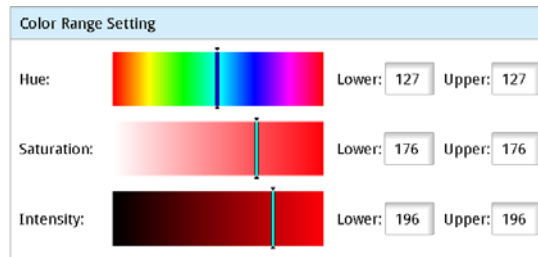

HSI color picker interface